

**ED2 SERIES
DEVICES**

Operation manual

Version 7.1.1.1 and higher

EKRA.650321.001-02 OM

**IMPORTANT: READ CAREFULLY BEFORE USE.
STORE FOR FUTURE USE.**

Copyright © RPE Ltd EKRA 2023. All rights reserved.

The disclosure, duplication, distribution and editing of this document, or utilization and communication of the content are not permitted, unless authorized in writing.

All rights, including rights created by patent grant or registration of a utility model or a design, are reserved.

Document code: EKRA.650321.001-02 OM

Edition: 05.2023



CAUTION

Do not turn on the device before reading this document!

The default predefined users and passwords are shown in table 1.

Table 1

Default User	Login	Password
Administrator	admin	0100
Protection and control engineer	engineer	0200
Operator	operator	0300



NOTICE

In order to ensure information security, it is recommended to change the default passwords before operation start.

In case of password loss one shall inform the manufacturing enterprise.

Contents

1 Preface	6
1.1 Purpose of this operation manual	6
1.2 The target audience.....	6
1.3 Functionality and field of application of devices	6
1.4 Related documentation.....	6
1.5 Compliance with standards.....	9
1.6 Support.....	9
1.7 Manufacturer's address	9
1.8 Training	9
1.9 Safety	10
2 Introduction	12
2.1 General	12
2.2 Brief overview.....	13
2.2.1 Design	13
2.2.2 Power supply	13
2.2.3 AC current and voltage analog inputs	14
2.2.4 DC current and voltage analog inputs	14
2.2.5 Analog inputs of digital samples (Sampled Values).....	14
2.2.6 Binary inputs	14
2.2.7 Binary outputs.....	14
2.2.8 Human-machine interface (HMI)	14
2.2.9 Communication.....	15
2.2.10 Time synchronization.....	15
2.2.11 Setting groups.....	15
2.2.12 Programmable logic.....	15
2.2.13 Event recorder and disturbance recorder	15
2.2.14 Self-diagnosis	15
2.2.15 Information security.....	15
3 General instructions	16
3.1 Device unpacking	16
3.2 Incoming inspection.....	16
3.3 Device repacking	17
3.4 Device return	17
3.5 Device storing.....	17
3.6 Checking the device before using it for the first time	18
3.7 Disposal	18

4	Technical data.....	19
4.1	Analog input	19
4.2	Binary input	19
4.3	Supply voltage.....	19
4.4	Power consumed by the device	20
4.5	Binary output	20
4.6	IED time readiness	21
4.7	Battery.....	21
4.8	Enclosure	21
4.9	Electrical safety	21
4.10	Environmental conditions.....	22
4.11	Type tests.....	22
5	General information about device design	25
5.1	Design types of devices	25
5.2	Device composition	26
5.3	Back plate of device.....	27
5.4	Terminal connectors of device	27
5.5	Sealing of the device	28
5.6	Device marking.....	29
5.7	Device connectors for external mounting	30
5.8	Types of device front panel.....	34
5.9	General view, dimensions and weight.....	35
6	Device modules	39
6.1	Logic module	39
6.2	Power supply module	44
6.3	Combined logic and power supply module.....	48
6.4	Binary input module	53
6.5	Binary output module.....	55
6.6	Combined binary I/O module	58
6.7	Analog input module.....	60
6.7.1	Transformer modules of analog inputs	60
6.7.2	Transformerless analog input modules	64
6.7.3	Transformer modules with frequency filters for analog inputs.....	67
6.8	Indication module	69
7	System software for ED2 devices.....	73
7.1	Programmable logic (PL)	73
7.2	Event recorder	75

7.3 Disturbance recorder	75
7.4 Synchronizing device date and time	77
8 Operation with the device from the front panel	79
8.1 Navigating the device menu	80
8.2 Updating and restoring the software of the ED2 series device	132
8.3 Return to previous version of software via device menu	135
9 Diagnostic functions	138
9.1 Self-diagnostic	138
9.2 Diagnostic of device operation using the human-machine interface (HMI)	138
10 Information security	144
11 Assembly	148
11.1 Safety measures	148
11.2 Equipment and documentation required for assembly	148
11.3 General	149
11.4 Installation of device	150
11.5 Installation dimensions on site	155
11.6 Installation of ED2 devices of 1/3 19" design with reduced installation depth	157
11.7 Making electrical connections of device	158
12 Commissioning instructions	160
12.1 General instructions	160
12.2 Device testing functions using the HMI and Smart Monitor software	161
12.3 Recommended equipment for commissioning	161
12.4 Decommissioning	161
12.5 Device check	162
12.6 Load current check	165
12.7 Final checks	166
13 Troubleshooting	168
13.1 Safety measures	168
13.2 General	168
13.3 Troubleshooting procedure	169
13.4 Determining cause of device failure and methods for its elimination	171
13.5 General principle of device disassembly and module removal	180
13.6 Replacement of device components	183
13.7 Replacement and/or recovery of configuration and software	191

1 Preface

1.1 Purpose of this operation manual

This operation manual contains a technical description of the ED2 series devices (hereinafter referred to as devices or ED2 series devices), as well as instructions for using these devices.

1.2 The target audience

This manual is intended for relay protection engineers, specialists in commissioning, testing and maintenance of protection, automation and control devices, operating personnel of electrical installations of power plants and substations.

1.3 Functionality and field of application of devices

1.3.1 The ED2 series devices are used at power plants and substations as:

- devices for protection and automation of station and substation equipment, generating units, including metal and oil and gas industry, as well as control and automation purposes;
- automation devices designed for creation of remedial action scheme (RAS), as well as emergency control of power generation units and power districts of stations and substations;
- recording devices for installation in power stations and substations to register analog and logical signals in case of disturbances accompanying normal modes in the power system;
- control devices of circuit breaker and bay switching devices, interlocking, acquisition and processing of analog and binary information.

1.3.2 Device can be mounted in set switchgears, cabinets or on panels and performs a standard type of protection, control and management functions, functions set can be changed in an individual project.

1.4 Related documentation

At different stages of the life cycle of the ED2 series devices, appropriate documentation may be required. The list and title of the documentation covering a certain life cycle (figure 1):

- certification guide. The certification manual contains the entire list of current certificates and requirements that the ED2 series devices comply with;
- catalog of standard versions of devices. The device version catalog contains all the information you need for planning and purchasing. Contains a description of the functions and application of each specific device of the ED2 series;
- operation manual for a series of devices. The operation manual for a series of devices describes the basic principles of operation, actions for the operation and installation of devices of the ED2 series;

– operation manual for a specific device version. The operation manual for a specific version of the device contains basic information about the assembly and installation of the device, technical data, permissible values of inputs and outputs, conditions for preparing the device for operation;

– EKRASMS-SP software package. The manual for the software package “EKRASMS-SP” describes the basic principles of working with the applied software of the ED2 series devices;

– Waves software user manual. The user manual for working with the Waves software contains complete information on working with disturbance records and their analysis;

– communication, time synchronization and network redundancy protocols manual. The communication, time synchronization and network redundancy protocol manual includes a description of interface protocols, time synchronization protocols and methods for organizing network redundancy in the ED2 series devices;

– Online materials and YouTube video tutorials. Online materials and video tutorials on YouTube, available around the clock on the Internet, describe the basic operations for working with application software, operation and operations with the functionality of devices.







	Planning and purchase	Engineering	Mounting	Commissioning	Operation	Maintenance	Decommissioning
 Certification Guide	Active	Inactive	Inactive	Inactive	Inactive	Inactive	Inactive
 Catalog of device types	Active	Active	Inactive	Inactive	Inactive	Inactive	Inactive
 Operation manual for a series of devices	Active	Active	Active	Active	Active	Active	Active
 Operation manual for a specific device version	Active	Active	Active	Active	Active	Active	Active
 EKRASMS-SP software package manual	Inactive	Active	Inactive	Active	Active	Active	Inactive
 Waves software manual	Inactive	Inactive	Inactive	Active	Active	Active	Inactive
 Communication, time synchronization and network redundancy manual	Inactive	Active	Active	Active	Active	Inactive	Inactive
 Online materials and Youtube video tutorials	Active	Active	Active	Active	Active	Active	Active

Figure 1 – Use of documents at different stages of the life cycle for ED2 series devices

1.5 Compliance with standards

This section is under development.

1.6 Support

Manufacturer's website	https://ekra.ru/	
E-mail	support@ekra.ru	-
Software Support Page	https://soft.ekra.ru/smssp/en/downloads/software/	-
Operational documentation	https://soft.ekra.ru/smssp/en/downloads/documents/	
Video tutorials on working with ED2 devices	https://www.youtube.com/playlist?list=PLSHLRtVG8WJeMyAaGOtNibkO_r2eyJimN	

1.7 Manufacturer's address

Address: STE 541, 3 Yakovlev Prospect, Cheboksary, Chuvashia – Chuvash Republic, 428020, Russia

E-mail: ekra@ekra.ru
ekra3@ekra.ru

1.8 Training

EKRA Training Center implements advanced training programs for products manufactured by EKRA Group and their applications at the facilities. Requests for training courses should be sent to:

Address: 3 Yakovlev Prospect, Cheboksary, Chuvashia – Chuvash Republic, 428020, Russia

E-mail: training@ekra.ru

1.9 Safety

1.9.1 Warning

Warning signs are used throughout this manual to advise the user to be careful when performing certain operations to avoid personal injury and property damage.

Only qualified electrical personnel should perform commissioning works and operate the equipment described in this document. The qualified electrical personnel as per this manual are people who have the qualifications of an engineer, electrician, wireman. These technicians can commission systems and circuits, inspect insulation, grounding, and instrument labeling in accordance with safety standards.



DANGER

failure to follow safety precautions will certainly result in death or serious injury



WARNING

failure to follow safety precautions may result in death or serious injury



CAUTION

failure to follow safety precautions may result in moderate or minor injury



NOTICE

failure to follow safety precautions is not dangerous to life and health, but is fraught with other undesirable consequences, for example, losses

1.9.2 Instructions

This documentation contains instructions for the installation, commissioning and operation of this equipment. However, the documentation may not cover all possible situations. In case of questions or problems, you should not take any further action without obtaining the necessary permission from the manufacturer. In this case, in order to obtain the relevant information, it is necessary to send a corresponding request to the technical department of the manufacturer.

This document is not a complete guide to all safety precautions required when using the devices. However, it contains information that you should pay attention to in order to ensure your own safety, as well as in order to avoid material damage.

Personnel associated with this device must know the contents of this document.

Only professionally skilled and trained personnel may be allowed to work with the device. Qualified personnel are persons who:

- know the methods of installation, adjustment and maintenance of equipment and systems with which it is associated;

- know the methods of supplying voltage and disconnecting equipment adopted in the power system, and must also be authorized to perform these works;
- are trained in the use of protective equipment applied in accordance with the safety instructions;
- have been trained to behave in an emergency (first aid).

Improper handling of the device and non-observance of safety measures can be dangerous for the operating personnel.

Failure to observe the following precautions can result in death, serious injury to personnel and damage to property:

- the equipment must be grounded through the earth terminal before making any connections;



WARNING

Meeting this grounding requirement is mandatory.

- all circuit components connected to the power source may carry hazardous voltages;



WARNING

Hazardous voltages are present on some parts of the device during operation!

- hazardous voltages may be present in the equipment even after the supply voltage has been removed (capacitors may still be charged);



WARNING

Hazardous voltages are present in some parts of the device when disconnecting the device!

- the operation of operating equipment with open secondary circuits of the current transformer is prohibited;



WARNING

Opening of the secondary circuits of current transformers on operating equipment must not be permitted!

- do not exceed the limit values for the input values (supply and binary input voltages, as well as the currents and voltages of the analog inputs) given in this document.



WARNING

Exceeding the limit values of the input values can damage the device!

1.9.3 The functional purpose, design and composition of the device's functions are reflected in the order code for the device.

1.9.4 For ordering information, refer to the version manual.

2 Introduction

2.1 General

ED2 is a digital device based on a powerful microprocessor system, the main components of which are two microprocessors - a functional processor and a communication processor. The device is in cyclic scan mode. It reads the input signals, solves the logic program with the establishment of the state of each output, corresponding to the given algorithm. As a result, all tasks, from receiving and processing signals to issuing commands, are performed digitally.

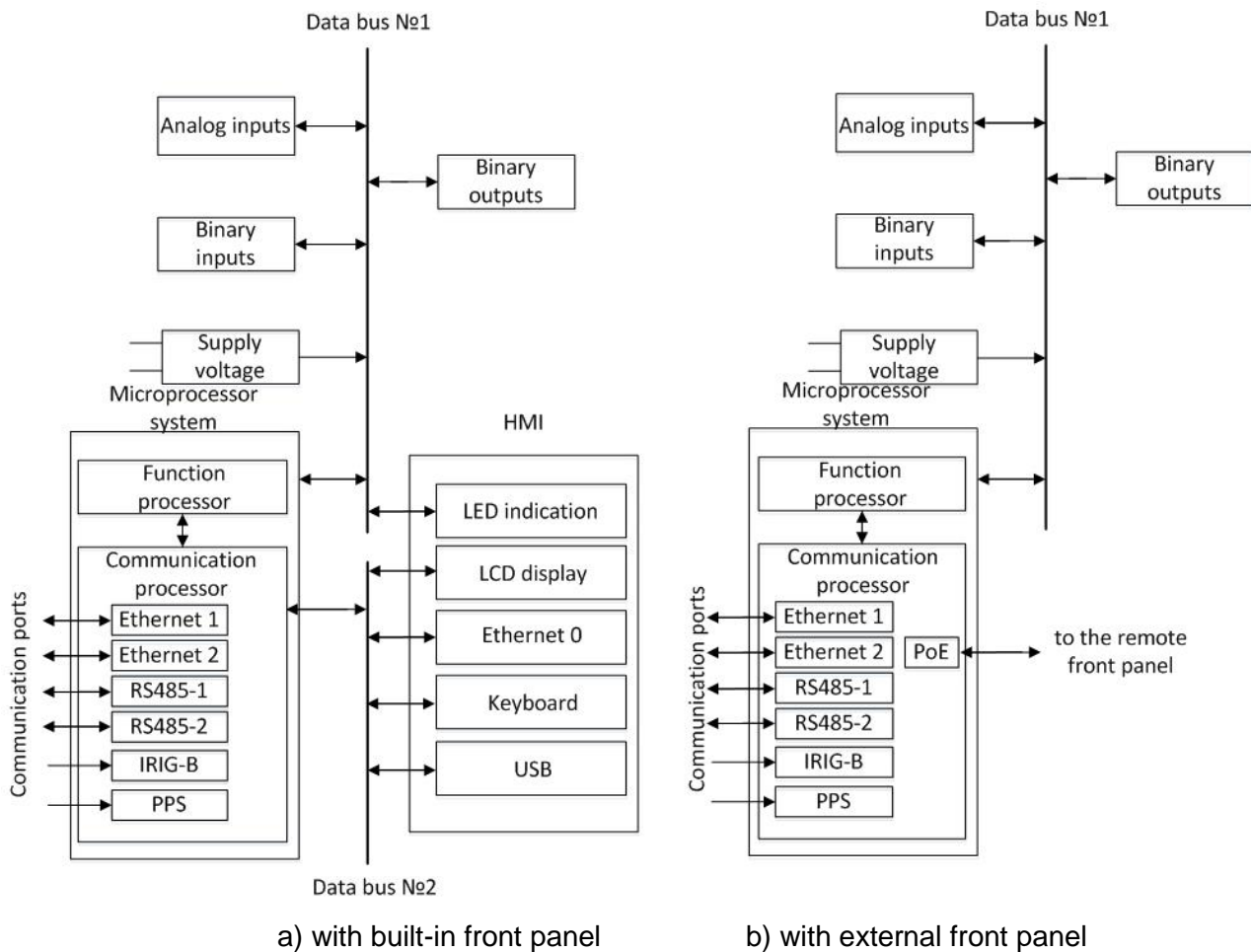

Figure 2 – Structural diagram of data processing by the ED2 device

The functional processor (FP) is designed to process input signals, work with digitized values of currents and voltages (samples), and generate output signals by acting on the module of binary outputs. In the functional processor, logic algorithms are executed, including with the help of programmable logic elements.

The communication processor (CP) carries out the functions of data exchange via a local area network (LAN) with an operator interface, an PCS (process control system) or other devices via the available communication ports of the device, work with calculated values (custom formulas), and functions of disturbance recording and emergency event recorder are also implemented in the communication process.

To record analog and binary information, a special easily removable non-volatile memory is used – a memory card (Compact Flash Card), information in which is stored even in the absence of supply voltage.

The operation of the device occurs according to the program recorded on the memory card.

Protection settings and device configuration are stored in a memory card that allows multiple changes of contents.

The real-time clock allows recording the actual time of events. To save information about the actual time when the power is turned off, a lithium battery is provided in the logic module to power the clock.

All modules and nodes of the device are powered from the power supply module. The power supply module provides all nodes of the device with a stabilized voltage within the operating voltage range of the operating current, as well as protection of electronic components from interference and overvoltage.

As a source of analog inputs, there can be modules of transformer inputs, modules of transformerless inputs, transformer modules with frequency filters for analog inputs, modules of receiving Sampled Values and digital communication channels. The analog inputs receive current and voltage values and convert them for internal processing by the device.

Binary inputs are designed to receive signals from external devices, for example, on/off commands and further transfer them to the FP. Binary inputs provide galvanic isolation of the internal circuits of the device from external circuits using optoelectronic converters.

Binary outputs are designed to transmit commands to external control and signaling circuits. Binary outputs provide galvanic isolation of the internal circuits of the device from external circuits.

Using the LCD display located on the front panel of the device, it is possible to display the current values of currents and voltages at the analog inputs, the status of binary inputs, setting values, mimic diagrams. Using the keyboard, the device is controlled (changing the values of settings, states of electronic switches, controlling the switching devices). LED indicators on the front and rear panels of the device provide signaling of the current state of the device, the operation of protections and automation, the current state of the ports.

2.2 Brief overview

2.2.1 Design

Structurally, the device can be manufactured with the following sizes $\frac{1}{3}$, $\frac{1}{2}$, $\frac{3}{4}$ and 19". According to the method of attachment to the surface to be mounted, it can be made for flush-mounting, flush-mounting with a decrease in the installation depth or surface mounting.

2.2.2 Power supply

The device is powered by an auxiliary DC system. The rated supply voltage values are given in the section 4.3.

It is possible to execute the device with two mutually redundant independent power supply units with hot-swap capability. If the power supply from one of the units is lost, the power supply from the second unit is switched over. In this case, the loss and restoration of power from one of the units does not affect the operation of the device.

2.2.3 AC current and voltage analog inputs

The device can receive a specified number of AC current and voltage analog signals, galvanically isolated from the internal circuits of the device. One analog input module can contain up to 12 analog inputs for connecting AC current and/or voltage circuits.

Rated values of AC current and voltage are set by the user, given in the section 4.1.

2.2.4 DC current and voltage analog inputs

The device can receive a specified number of DC current and voltage analog signals, galvanically isolated from the internal circuits of the device.

Rated values of DC current and voltage are given in the section 4.1.

2.2.5 Analog inputs of digital samples (Sampled Values)

The device can provide reception of digital samples of signals (or SV – Sampled Values) via technological local area network (further – «process bus») according to IEC 61850-9-2LE specification (depending on device version).



NOTICE

The device does not support simultaneous reception of digital samples SV and analog signals.

2.2.6 Binary inputs

The device provides reception of binary signals from external control and automation devices with galvanic isolation from the internal circuits of the device.

The rated voltage of the binary inputs is given in the section 4.2.

2.2.7 Binary outputs

The device may contain standard electromechanical or high-speed output relays, the contacts of which are galvanically isolated from the internal circuits of the device. Type of transmitted signal - "dry contact".

2.2.8 Human-machine interface (HMI)

The user can manage, configure and monitor the functions and measurements of the device using the display and keyboard and/or remotely using the application software located on the display panel.

The device may include an indication panel for local signaling, implemented using LED indicators and/or a graphic display to display information about the operation of the device; fault alarms; signaling (with "memorization") of the operation of protection or automation functions, binary inputs and outputs on LED indicators, stored in case of loss (disappearance, drawdown) of the operational supply voltage and restored when it appears.

Using the USB connector, you can quickly download the event recorder, disturbance recorders to a USB-flash drive; update software and/or device configuration.

2.2.9 Communication

The device can communicate with external devices using various data exchange protocols: Modbus RTU/TCP, IEC 60870-5-103, IEC 60870-5-104, IEC 61850-8-1, IEC 61850-9-2LE with support for simultaneous connection to device up to 10 clients. Details are given in table 26.

Ethernet ports can be either electrical (RJ45 connector) or optical (LC connector).

Redundancy of Ethernet communication channels can be supported using the LinkBackup (Ethernet Link Redundancy), PRP (Parallel Redundancy Protocol) protocols.

2.2.10 Time synchronization

The device supports hardware and software synchronization of the device's internal clock.

Software time synchronization protocols: Modbus RTU/TCP, IEC 60870-5-103, IEC 60870-5-104, SNTP, PTPv2 (standard IEEE1588).

Hardware time synchronization protocols: IRIG-B, PPS.

2.2.11 Setting groups

The device supports up to 8 individual setting groups. Switching from one group of settings to another can be carried out via a binary input or using electronic switches located on the display of the device, or remotely using application software or using the IEC 61850 protocol.

2.2.12 Programmable logic

The user can create and edit the programmable logic of the device using a graphical tool that allows you to implement solutions in accordance with the specifics of the equipment application.

More details about programmable logic are described in section 7.1.

2.2.13 Event recorder and disturbance recorder

The device provides a function of emergency disturbance recording with record in COMTRADE 2013 format; transmission of disturbance records and events with a time stamp via digital communication channels (including IEC 61850-8-1).

The device can register up to 7500 events in normal and emergency modes with a resolution of 1 ms, stored in the non-volatile memory of the device.

For more information about disturbance recorder and event recorder of emergency events, see section 7.2 and section 7.3.

2.2.14 Self-diagnosis

The device has a self-diagnostic function that monitors failure situations that occur during operation and informs the user about damages through the HMI and through communication channels.

2.2.15 Information security

The device implements protection against unauthorized user actions, exclusion of unauthorized changes to the device configuration through a password system. By default, 3 user groups are defined with different access rights and individual standard passwords shown in the table 1. In order to ensure information security, it is recommended to change the default passwords before starting operation.

3 General instructions

3.1 Device unpacking

Before delivery to the Customer, all devices undergo acceptance tests (hereinafter referred to as AT). Passage of the AT is confirmed by the test report, which is available in the accompanying documentation.

Tools and accessories for unpacking of the device shown in table 2.

Table 2 – Tools needed for unpacking device

Name	Specifications	Type of works
Scissors	Type – for steel strip with the following specifications: Maximum thickness of sheet – 1.5 mm; Maximum width of strip – 50 mm	Cutting steel tape, adhesive tape, film
Nail puller or tongs; pliers; forked hammer	–	Removing nails from the device packaging

After receiving the device, we recommend that you do the following:

- check the packaging for external damage that may have appeared during transportation.

Damaged packaging may indicate that the device inside has also been damaged;

- carefully unpack the device, take it out of the package;
- carry out the incoming control of the device in accordance with the subsection

3.2 “Incoming inspection”;

- check the completeness of the delivery (accompanying documentation and ordered accessories) for compliance with the order code;

– save the packaging in case the device needs to be stored or transported to another location;

- return the damaged device to the manufacturer, indicating the defect. Use the original or shipping packaging whenever possible.

3.2 Incoming inspection

3.2.1 Security notifications



Error to follow the safety instructions can result in serious injury, death, or property damage.

When carrying out the incoming inspection, it is necessary to adhere to all the specified safety rules.

If the device is damaged or does not correspond to the order code, one should contact the service support center. In case of return, one should use the original transport packaging or other packaging that has characteristics not worse than the original packaging.

3.2.2 Visual inspection of the device

Immediately after unpacking the devices, it is necessary to visually inspect them for external damage; the device must show no signs of dents or cracks.

It is necessary to check the integrity of the label "Control of opening" (label location see figure 7). The "Control of opening" label must not show signs of damage.

3.2.3 Checking rated parameters of device

You must check the rated parameters and incorporated functions using the ED2 device using of ordering code found on the information plate located on the side of the device.

3.3 Device repacking

3.3.1 Devices must be repackaged if necessary for storage or further transport.

3.3.2 If the devices remain in storage after the incoming inspection, they must be packed in appropriate packaging for storage.

3.3.3 If the device is to be transported, it must be in the transport packaging.

3.3.4 Place the accessories (additional ordering options), test report and other accompanying documentation (if any) in the package with the device.

3.4 Device return

Devices with identified defects are subject to return. The reason for the return must be stated when returning the device to the manufacturer.

First, one should contact the service support center. In the event of a return, the original shipping packaging must be used. Devices must be returned to the following address:
STE 541, 3 Yakovlev Prospect, Cheboksary, Chuvashia – Chuvash Republic, 428020, Russia

When returning a device, one should make sure of the following:

- that the terminals included in the delivery are installed on the devices. If the terminals connected to the wires are left on site, no additional transport protection is required;
- that all the plugs provided by the design of the device are installed.

3.5 Device storing

3.5.1 Before putting the device into storage, an inspection must be carried out according to the recommendations in section 3.2. If defects are found, there are no plugs, terminals or other inconsistencies, you must contact the service support center.

3.5.2 Devices of the ED2 series must be stored in clean and dry rooms in the manufacturer's packaging at temperatures specified in the technical specifications for the device version (see section 4.10) and relative air humidity not more than 80%.

3.6 Checking the device before using it for the first time

3.6.1 Precautionary measures



WARNING

Danger when connecting a device!

Error to follow the safety instructions can result in serious injury, death, or property damage.

Before applying power to the device for the first time, it must be in the working room for at least 2 hours. This prevents condensation from forming in the device.

3.6.2 Grounding the device

According to the requirements of protecting a person from electric shock, ED2 series devices correspond to class I according to IEC 60255-27.

The device metal structure has a screw with M5 thread for grounding conductor connection (copper wire) with cross-section of minimum 6 mm² (AWG 9), which should be used exclusively for connection to the ground ring (tightening torque: at least 1.2 N·m).



CAUTION

Meeting the grounding requirement for the ED2 is mandatory!

3.6.3 Device connection

Perform wiring and connect communication cables. To do this, use the device connection diagrams given in the design type manual.

Tighten all screw connections of the connectors on the rear of the device to the specified tightening torque (tightening torque: at least 1.2 N·m).

More complete information on installation is presented in the section 11 "Assembly".

3.7 Disposal

The device is subject to disassembling and recycling after the full life cycle. No special safety measures are required during disassembly and disposal. Dismounting and disposal require no special equipment or tools.

4 Technical data

4.1 Analog input

Table 3 – Specifications of analog input

Parameter	Value
Analog inputs rated AC I_{nom} , A	0.15; 0.3; 1.0; 2.5; 5.0
Operating range of input ACs, A	$(0.05 - 40.0) \cdot I_{nom}$
Rated AC voltage of analog inputs U_{nom} , V	100 -120;
Operating range of analog inputs of AC voltages, V	0.3 – 264
Rated frequency of AC analog signals f_{nom} , Hz	50; 60
Analog inputs rated DC I_{nom} , A	0.001; 1
Operating range of input DCs, A	± 0.032 for $I_{nom} = 0.001$ A; ± 40 for $I_{nom} = 1$ A
Rated DC voltage of analog inputs U_{nom} , V	100; 400
Operating range of analog inputs of DC voltages, V	± 264 for $U_{nom} = 100$ V; ± 600 для $U_{nom} = 400$ V

4.2 Binary input

Table 4 – Parameters of binary input

Parameter	Value	
Nominal voltage, U_{nom}	110/125 VDC	220/250 VDC
Control voltage	U_{oper} , V	82 ± 2
	U_{res} , V	162 ± 2
Maximum allowable voltage, V	150 VDC	300 VDC
Power consumption, at nominal voltage, no more, W	0.5	
Current consumption at nominal voltage, not less, mA	2	
Actuation time, ms	5	
Resistance in non-operated state, no more, kOhm	25	
Current impulse with a duration of not less than 1 ms at the level of 50 % of the amplitude value when applied U_{nom} , no less, mA	40	
The range of adjustment of technological (including bounce-proof) time delay	from 0 to 9.999 ms with a step of 1 ms	
The frequency of signal inquiry, no more, ms	1.0	

4.3 Supply voltage

Table 5 – Device power supply specifications

Parameter	Value	
Operating voltage	$U_n = 110, 125$ VDC	$U_n = 220, 250$ VDC
	Operating range $U = 88 - 150$ VDC	Operating range $U = 176 - 300$ VDC
Inrush current at power-on	No more than 11 A during 10 ms	
Operating time during power interruption	no more than 120 ms	
Recommended external protection	circuit breaker 4 A, characteristic C according to IEC 60898	

4.4 Power consumed by the device

Table 6 – The power consumed by the device, according to the auxiliary power supply circuits

Parameter		Structural design of device			
		1/3 19"	1/2 19"	3/4 19"	19"
Power consumed by the device	In standby mode, no more W	20	30	30	40
	In operation* mode, no more W	30	35	50	50

* When all relays of all modules of the device's output relays are closed simultaneously.

4.5 Binary output

The parameters of binary outputs implemented on standard relays are given in table 7, on high-speed relays - in table 8.

Table 7 – Standard electromechanical output relay parameters

Parameter		Value
Switching capacity, resistive load	Closure	2,000 VA (250 VAC, 8 A, 50,000 cycles); 75 W (250 VDC, 0.3 A)
	Opening	
Switching capacity, inductive load	Closure	L/R = 50 ms: 2,200 W (220 VDC, 10 A) – 1.0 s; 3,300 W (220 VDC, 15 A) – 0.3 s; 6,600 W (220 VDC, 30 A) – 0.2 s; 8,800 W (220 VDC, 40 A) – 0.03 s
	Opening	L/R = 20 ms: 30 W (220 VDC, 0.14 A, 10,000 cycles); L/R = 50 ms: 55 W (220 VDC, 0.25 A, 2,000 cycles)
Minimum making capacity, not less		10 mA at 5 VDC
Relay mechanical life (no load), not less		10 ⁷ cycles
Thermal resistance of contacts		10 A – for long duration, 30 A – 0.2 s
Actuation time, ms		6 – 10
Reset time, ms		3 – 5
Test voltage between open contacts, 1 min		1000 VAC

Table 8 – Parameters of high-speed output relays (DC voltage only)

Parameter		Value
Switching capacity, resistive load	Closure	1000 W (250 VDC, 4 A, 10000 cycles)
	Opening	
Switching capacity, inductive load	Closure	L/R = 50 ms: 1000 W (250 VDC, 4 A, 10000 cycles)
	Opening	L/R = 20 ms: 30 W (220 VDC, 0.14 A, 10000 cycles); L/R = 50 ms: 55 W (220 VDC, 0.25 A, 2000 cycles)
Relay mechanical life (no load)		10 ⁷ cycles
Thermal resistance of contacts		8 A – for long duration, 30 A – 0.2 s (2000 cycles)
Actuation time, s		< 1
Reset time		3 – 4

4.6 IED time readiness

Table 9 – IED time of readiness after supply of operating current voltage

Parameter	Value
The IED time of readiness after supply of operating current voltage to perform main functions (functions of relay protection, automation and control)	no more 1 s
The IED time of full readiness after supply of operating current voltage (taking into account the self-test time)	no more 60 s
The IED time of full readiness with reception signals to the SV protocol after supply of operating current voltage (taking into account the self-test time)	no more 90 s
The IED time of full readiness after supply of operating current voltage (taking into account the self-test time, synchronization with ASU)	no more 300 s

4.7 Battery

Table 10 – Specifications of battery

Parameter	Value
Type	CR2032 Tablet Lithium
Voltage	3 V
Capacity	230 mAh

4.8 Enclosure

Table 11 – Specifications of device enclosure

Material of enclosure	Sheet steel
Surface treatment	Galvanized steel (optional galvanized coating is possible)
Face plate	Rolled metal coated with 180 µm thick polyester film

Table 12 – Level of moisture and dust protection in accordance with IEC 60529

Parameter	Value
Protection against access to hazardous parts	IP2X
Enclosure protection degree (front part)	IP51
Enclosure protection degree (rest)	IP20*
* At the request of the customer, it is possible to design the device with a degree of protection up to IP52 (except for input and output clamps for connecting conductors); the device as a whole when using an additional protective frame – only for ED2 devices of 1/3 19" design.	

4.9 Electrical safety

Table 13 – Electrical safety in accordance with IEC 60255-27

Specification	Value
Equipment safety class	I (with protective earthing)
Overvoltage category	III

4.10 Environmental conditions

Table 14 – Recommended environmental parameters

Parameter	Value
Recommended for continuous operation (according to IEC 60255-1), °C	from -10 to +55
Temporary permissible operating temperature, °C	from -25 to +60
Long-term storage and transportation temperature, °C	from -40 to +70
Maximum installation altitude, m	up to 2000
Operating position	vertical with a deviation from the operating position up to 5° in any direction
Environment	non-explosive environment without current-conducting dust, aggressive gases or vapors in insulation- or metal-damaging concentrations
Degree of pollution	I (no pollution or only dry, non-conducting pollution)

4.11 Type tests

Table 15 – Parameters of environmental tests

Testing	Typical check value	Standard
Testing at low temperatures (temporary operation)	Test Ad for 16 hours at -25 °C ¹⁾	IEC 60068-2-1
Testing at low temperatures (long-term operation)	Test Ad for 96 hours at -10 °C	IEC 60068-2-1
Testing at low temperatures during storage and transportation	Test Ab for 96 hours at -40 °C	IEC 60068-2-1
Dry heat test (long-term operation)	Test Bd for 96 hours at +55 °C ²⁾	IEC 60068-2-2
Dry heat test (temporary job)	Test Bd for 16 hours at +60 °C ²⁾	IEC 60068-2-2
Dry heat test during storage and transportation	Test Bd for 96 hours at +70 °C ²⁾	IEC 60068-2-2
Damp heat test, steady state	Test Ca for 10 days at + 55 °C and humidity 93 % ³⁾	IEC 60068-2-78
Damp heat test, cyclic	6 test cycles Db in the range from +25 to + 55 °C and humidity 93-95 % ³⁾ (1 cycle = 24 hours)	IEC 60068-2-30
¹⁾ At temperatures below minus 20 °C the readability of the display may be impaired. ²⁾ The enclosure of the device may darken. ³⁾ Corrosion may occur on the edges of the device enclosure.		

Table 16 – Parameters of insulation

Parameter	Value
Standards	IEC 60255-27
Insulation strength (standard test), current measurement inputs, voltage measurement inputs, output relays, power port, binary inputs	2,000 VAC 50 Hz 1 minute
Insulation strength (standard test), only isolated communication interfaces (excluding RS-485), PPS/IRIG-B time synchronization interfaces	1,000 VAC 50 Hz 1 minute
Table continued on next page	

Parameter	Value
Withstand voltage impulse (type test), all circuits except communication and time synchronization interfaces, Class 3	5 kV peak 1.2 μ s / 50 μ s 0.5 J 3 positive and 3 negative pulses at 1 s intervals
Withstand voltage impulse (type test), RS-485 communication and PPS/IRIG-B time synchronization circuit, Class 2	1 kV peak 1.2 μ s / 50 μ s 0.5 J 3 positive and 3 negative pulses at 1 s intervals
Insulation resistance	>100 MOhm at 500 VDC
Resistance of protective equipotential bonding	<0.1 Ohm
Rated insulation voltage	500 V

Table 17 – Parameters of electromagnetic compatibility

Parameter	Value
Standards	IEC 60255-1 and IEC 60255-26 (product standards) IEC 61000-6-2 (main industry standards)
Testing for electrostatic discharge IEC 61000-4-2	Contact discharge \pm 8 kV Air discharge \pm 15 kV
Testing for immunity to radiated radio-frequency electromagnetic field, Frequency sweep IEC 61000-4-3	30 V/m, 80 MHz to 1 GHz 30 V/m, 1.4 to 2.7 GHz 30 V/m, 2.7 to 6 GHz 80 % amplitude modulation, 1 kHz
Testing for immunity to radiated radio-frequency electromagnetic field, Fixed frequencies IEC 61000-4-3	20 V/m, 80 MHz/160 MHz/380 MHz/450 MHz/900 MHz 20 V/m, 1.85 GHz/2.15 GHz 80 % amplitude modulation, 1 kHz Duration of actuation delay \geq 30 s
Testing for immunity to electrical fast transient IEC 61000-4-4	4 kV, 5 ns / 50 ns 5 kHz, 100 kHz Pulse length = 15 ms; Repetition rate 300 ms Both polarities R _{hv} = 50 Ohm Test duration \geq 5 min
Testing for pulse overvoltage IEC 61000-4-5 (high energy microsecond impulse interference)	Pulse: 1.2 μ s / 50 μ s
	Power supply, signal, analog and binary circuits
Testing for immunity to conducted interference induced by radio-frequency electromagnetic fields, Amplitude modulation IEC 61000-4-6	10 V, 150 kHz – 80 MHz, 80 % ampl. mod., 1 kHz
Testing for immunity to conducted interference induced by radio-frequency electromagnetic fields, Amplitude modulation IEC 61000-4-6 Fixed frequencies	27 MHz/68 MHz at 10 V, duration of actuation delay \geq 10 s 80 % ampl. mod., 1 kHz
Testing for resistance to power frequency magnetic field IEC 61000-4-8	100 A/m (continuous) 1,000 A/m for 3 s
Pulsed magnetic field IEC 61000-4-9	1,000 A/m, 8 μ s / 20 μ s
Testing for immunity to damped oscillatory waves IEC 61000-4-18	100 kHz, 1 MHz, 2.5 kV peak Test duration \geq 60 s
Testing for immunity to conducted interference at 50 Hz on binary inputs IEC 61000-4-16	Area A 150 V (differential mode) 300 V (common mode)

Table continued on next page

Parameter	Value
Testing for immunity to conducted electromagnetic interference in the frequency range from 0 to 150 kHz IEC 61000-4-16	30 V, 30 Hz, long-term; 300 V, 300 Hz, short-term (1 s);
DC supply voltage ripple IEC 61000-4-17	15 % Unom
Testing for dips and interruptions of DC power supply voltage IEC 61000-6-5 IEC 61000-4-29	40 % Unom, 1 s 70 % Unom, 1 s 100 % Unom, 0.1 s (without using an additional filter module)
Testing for immunity to ring wave IEC 61000-4-12	Common mode: 4 kV Differential mode: 2 kV
Testing for immunity to a damped oscillatory wave IEC 61000-4-18	Common mode: 2 kV Differential mode: 1 kV

Table 18 – Parameters of emission

Parameter	Value	
Standards	IEC 60255-26 (product standards) IEC 61000-6-4 (main industry standards)	
Conducted emissions on supply voltage lines CISPR 22	150 kHz – 30 MHz, Restriction Class A	
Radiation	CISPR 11	30 MHz – 1,000 MHz, Restriction Class A
	CISPR 22	1 GHz – 6 GHz, Restriction Class A

Table 19 – Parameters of mechanical tests for vibration and shock load during operation (stability)

Parameter	Value
Standard	IEC 60255-21 and IEC 60068
Vibration test (sinusoidal) IEC 60255-21-1, Class 2	Sinusoidal from 10 to 150 Hz: 10 m/s ² acceleration Frequency sweep 1 octave/min 20 cycles in three axes perpendicular to each other
Shock test IEC 60255-21-2, Class 2 Half-sinusoidal	Half-sinusoidal 100 m/s ² acceleration 11 ms duration 3 impact shocks on each of the 3 axes in both directions
Seismic tests IEC 60255-21-3, Class 2	Sinusoidal from 3 Hz to 35 Hz: Frequency sweep 1 octave/min 1 cycle in three axes perpendicular to each other from 3 to 8 Hz: ±7.5 mm amplitude (horizontal axes) from 3 to 8 Hz: ±3.5 mm amplitude (vertical axes) from 8 to 35 Hz: 20 m/s ² acceleration (horizontal axes) from 8 to 35 Hz: 10 m/s ² acceleration (vertical axes)

Таблица 20 – Parameters of mechanical tests for vibration and shock load during transportation (strength)

Parameter	Value
Standard	IEC 60255-21 and IEC 60068
Vibration test (sinusoidal) IEC 60255-21-1, Class 2	Sinusoidal from 10 to 150 Hz: 20 m/s ² acceleration Frequency sweep 1 octave/min 20 cycles in three axes perpendicular to each other
Shock test IEC 60255-21-2, Class 1 Half-sinusoidal	Half-sinusoidal 150 m/s ² acceleration 11 ms duration 3 impact shocks on each of the 3 axes in both directions
Long-term shock impacts IEC 60255-21-2, Class 1	Half-sinusoidal 100 m/s ² acceleration 16 ms duration 1,000 times in each of the 3 axes in both directions

5 General information about device design

5.1 Design types of devices

Devices of the ED2 series (see figure 3) are made in the form of a frame with a set of modules.

The device design types are shown in table 21.

Table 21 – Design types of ED2 series devices

Design type	Figure
$\frac{1}{3}$ 19" design	see Figure 3a
$\frac{1}{2}$ 19" design	see Figure 3b
$\frac{3}{4}$ 19" design	see Figure 3c
19" design	see Figure 3d



a) $\frac{1}{3}$ 19" design



b) $\frac{1}{2}$ 19" design



c) $\frac{3}{4}$ 19" design

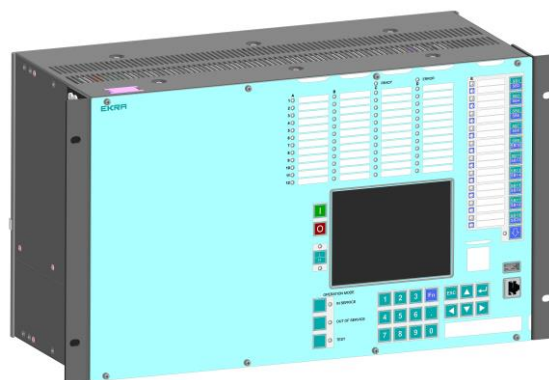

d) 19" design

Figure 3 – Appearance of ED2 series devices

5.2 Device composition

The ED2 series device may include the following modules:

- logic module¹⁾;
- power supply module;
- combined logic and power supply module¹⁾;
- module(s) of analog inputs of alternating current and voltage (transformer and transformerless);
- module(s) of analog inputs of direct current and voltage (transformerless);
- module(s) of binary inputs;
- module(s) of binary outputs;
- module(s) of binary inputs/outputs (combined module(s));
- module of reception of digitalized instantaneous values - Sampled Values (SV);
- indication module (front panel of the device with indication and control elements).

The quantity and contents of modules are determined by device design type.

Modules are installed into the frame by slide rails on the back side of the device (see figure 4). The indication module is installed on the front side of the device. For ED2 1/3 19" the front panel is non-removable.

Note – The location of the modules in the device is given in the manual for the device version.

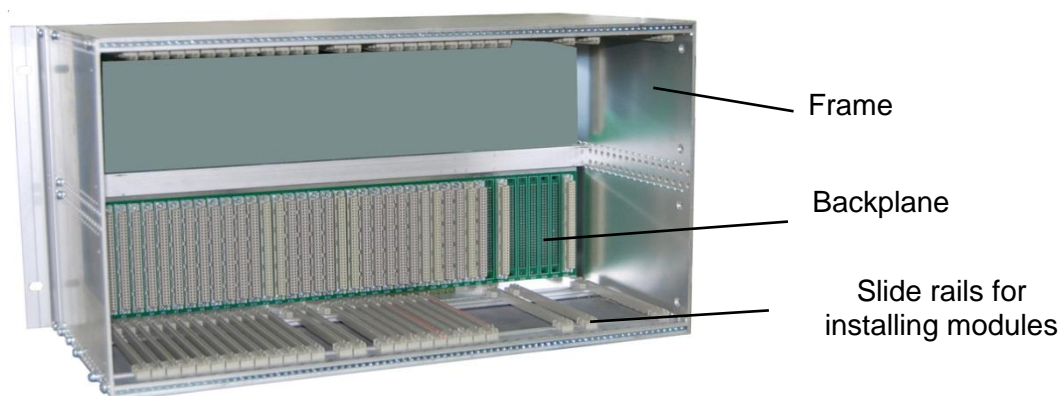

Figure 4 – General view of the frame (rear view)

¹⁾ In devices of 1/3 19" design.

5.3 Back plate of device

The back panel of ED2 series devices consists of a common cover plate with holes for the device connectors (see figure 5).

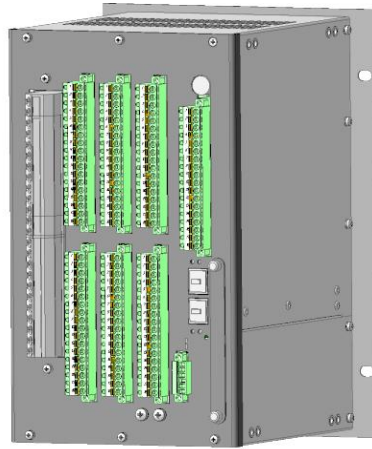

Figure 5 – General view of the back panel of ED2 series devices

5.4 Terminal connectors of device

The device has terminal connectors and connectors for connecting external circuits. Appearance, purpose and technical characteristics are given in clause 5.7.

The location of the terminal connectors on the rear panel are shown in the figure 6.

Each connector is marked according to the circuit diagram of the device (see figure 7).

The ground screw is appropriately marked (see figure 7).

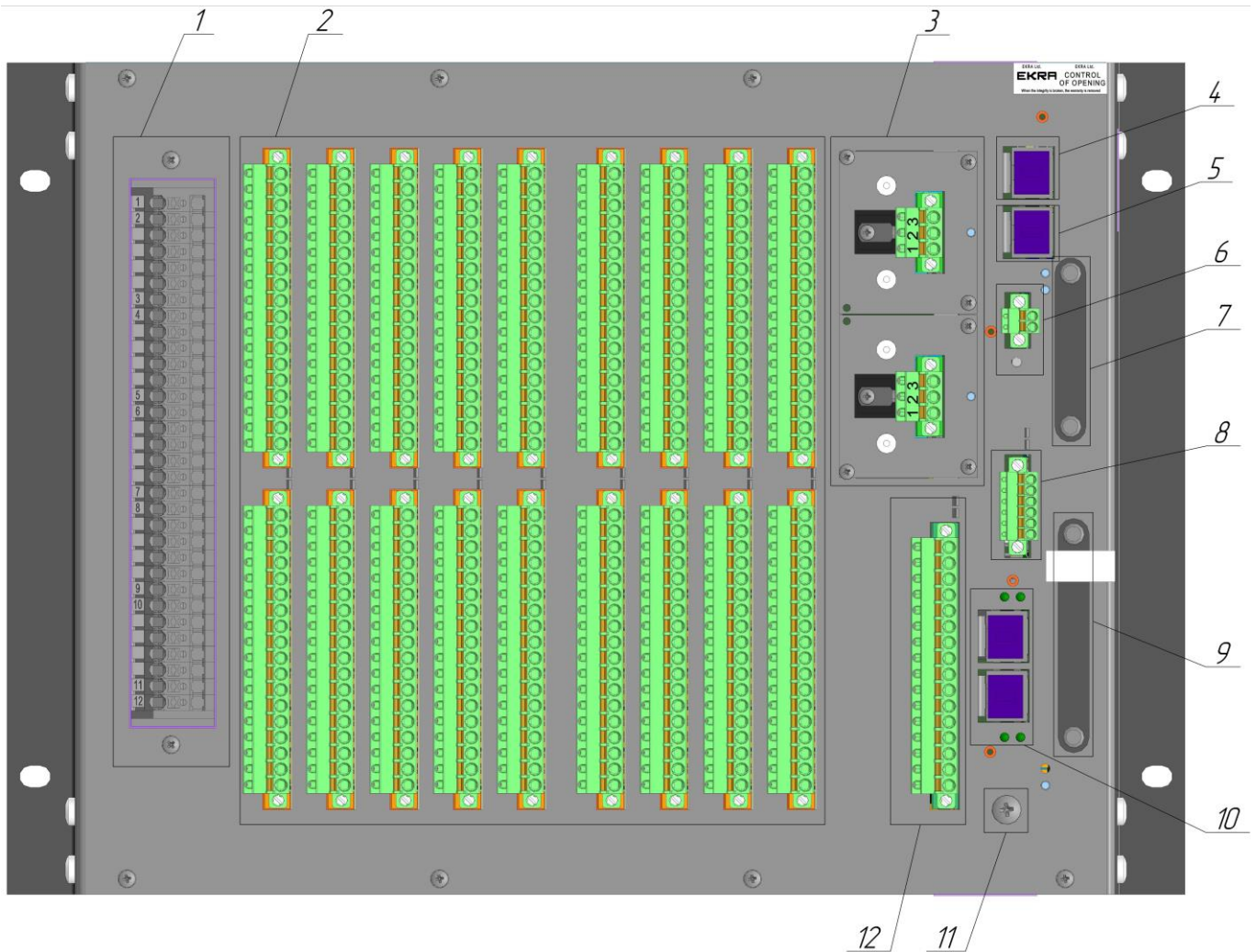

- 1 - Terminal connectors for current and voltage circuits;
- 2 - Connectors of binary inputs and output circuits;
- 3 - Connectors of power supply circuits;
- 4 - PoE – connector of Ethernet 0 interface (if there is no display panel);
- 5 - Connector of Ethernet 2 interface;
- 6 - Connector of time synchronization IRIG-B;
- 7 - Battery slot;
- 8 - Connector of RS 485 Interface;
- 9 - Memory card slot;
- 10 - Connector of Ethernet 1 interface;
- 11 - Ground screw;
- 12 - Connectors of service binary inputs/outputs and hardware time synchronization circuits

Figure 6 – General view of the ED2 devices of $\frac{3}{4}$ 19" design, rear view

5.5 Sealing of the device

The devices are sealed with a special label (seal) "Control of opening", which breaks upon device opening and is placed on the back plate of the device.

Additionally, to control the opening of the device, seals are provided on the memory card and its connector.

The presence of this seal guarantees that the manufacturer will ensure its obligations to repair and restore the device.

The absence of a seal or violation of its integrity voids the warranty from the manufacturer. The position of the label (seal) on the countersunk screw of the device is shown in the figure 7.

Figure 7 – Location of markings and labels "Control of opening" on the rear panel of the device

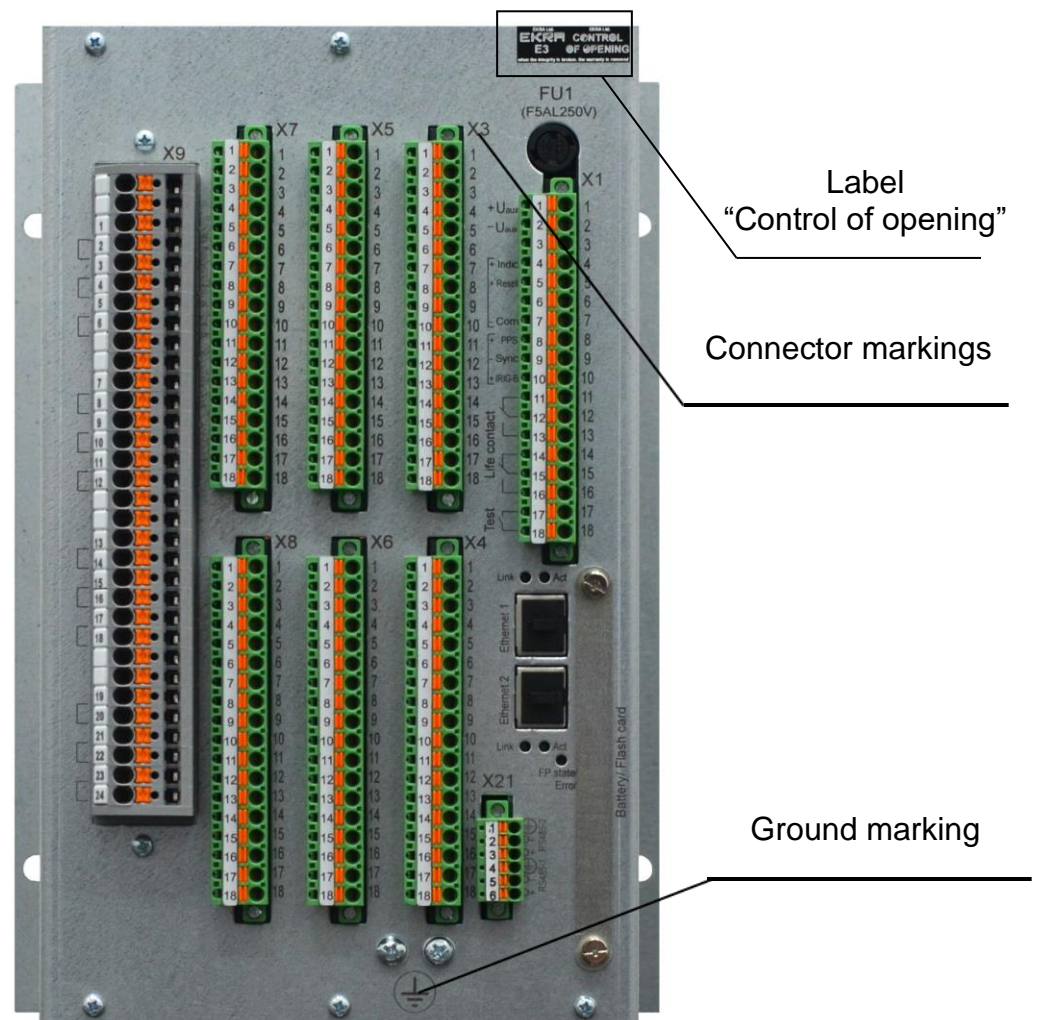



constructive $\frac{1}{3}$ 19"

5.6 Device marking

Each device has a plate on the side surface indicating the main parameters of the device (see table 22).

Additionally, on the front plate there is a short designation of the device version (see figures 35, 36).

Table 22 – Plate (marking) and explanation of the content

Parameter	Description
	Table with basic information
ED2-F	Device type ED2-F – feeder protection
Feeder Protection	Device functionality
Model	Version (complete order code) of the device
Serial Number	Serial number of the device
Mfg. Date	Date of device manufacture
UauxDC	Supply voltage DC – direct current voltage
Urated, Irated, frated	Nominal values of analog inputs of the device (voltages, currents, frequency)
	<p>Before switching on, you must study the documentation for the device:</p> <ul style="list-style-type: none"> - operation manual for a series of devices; - operation manual for a specific version of the device; - manual for the software package “EKRASMS-SP”; - user guide for operation with the Waves program; - a guide to interface protocols, time synchronization and network redundancy

5.7 Device connectors for external mounting

The connection to the current and voltage circuits of the device is made to the terminal block with "Push in" fastening type. Connection to the circuits of binary inputs and outputs, power circuits of the device is made to the terminal block with "Push in" or "Screw" fastening type. The location and marking of the connectors is given in clause 5.4.

Note – Execution «screw type» is an additional requirement and is specified when ordering.

The characteristics and appearance of the terminal blocks, as well as the parameters of the connectors, are given in table 23.

The number and purpose of the connectors depends on the version of the device.

Table 23 – Description of the connectors used in the device

Connector location	Connector appearance	Connector type	Connector characteristics
CT and VT circuit connectors		<p>Terminal block 32 poles for transformer current and voltage sensors</p>	<p>Nom. current = 24 A Nom. voltage = 500 V Conductor cross section: 0.14 – 4 mm² 26AWG...12AWG Connection method: Push in</p>
		<p>Terminal block 12 poles for transformerless current and voltage sensors</p>	<p>Nom. current = 41 A Nom. voltage = 1,000 V Conductor cross section: 0.2 – 10 mm² 24AWG...8AWG Connection method: Push in</p>
Auxiliary power supply, binary I/O connectors		<p>Terminal block 18 poles for binary I/O, power supply circuits</p>	<p>Nom. current = 12 A Nom. voltage = 320 V Conductor cross section: 0.2 – 2.5 mm² 24AWG...12AWG Connection method: Screw type</p>
		<p>Terminal block 18 poles for binary I/O, power supply circuits</p>	<p>Nom. current = 12 A Nom. voltage = 320 V Conductor cross section: 0.2 – 2.5 mm² 24AWG...12AWG Connection method: Push in</p>

Table continued on next page

Connector location	Connector appearance	Connector type	Connector characteristics
Power supply circuits		Plug 3 poles for power supply circuits	Nom. current = 12 A Nom. voltage = 320 V Conductor cross section: 0.2 – 2.5 mm ² 24AWG...12AWG Conductor cross section: Screw type
		Plug 3 poles for power supply circuits	Nom. current = 12 A Nom. voltage = 320 V Conductor cross section: 0.2 – 2.5 mm ² 24AWG...12AWG Connection method: Push in
Time synchronization IRIG-B		Plug 2 poles IRIG-B	Nom. current = 12 A Nom. voltage = 250 V Conductor cross section: 0.2 – 2.5 mm ² 24AWG...12AWG Connection method: Screw type
		Plug 2 poles IRIG-B	Nom. current = 12 A Nom. voltage = 320 V Conductor cross section: 0.2 – 2.5 mm ² 24AWG...12AWG Connection method: Push in
Communication RS-485		Plug 6 poles RS-485	Nom. current = 12 A Nom. voltage = 250 V Conductor cross section: 0.2 – 2.5 mm ² 24AWG...12AWG Connection method: Screw type
		Plug 6 poles RS-485	Nom. current = 12 A Nom. voltage = 320 V Conductor cross section: 0.2 – 2.5 mm ² 24AWG...12AWG Connection method: Push in

Table continued on next page

Connector location	Connector appearance	Connector type	Connector characteristics
Ethernet communication (RJ-45)		<p>Connector type RJ-45 for Ethernet 10/100 UTP (10/100BaseTX) communication interfaces</p>	<p>Connection method: RJ45 (shielded); Cable type: UTP cat. 5e; Maximum line length: 100 m</p>
Ethernet communication (LC-duplex)		<p>Connector type LC-duplex for 100BaseFX Ethernet communication interfaces</p>	<p>Connection method: LC-duplex Wavelength: 1300 nm Fiber type: 62,5/125 μm multimode fiber Safety class: 1 Maximum line length: 2 km</p>

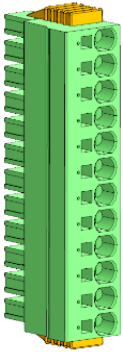
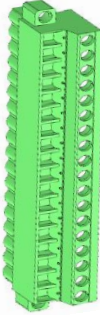
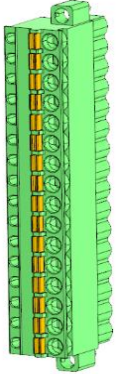
5.8 Types of device front panel

The front panels of the devices are display modules, the appearance of which depends on the size of the device (see figure 8)

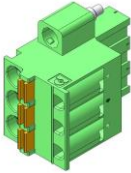
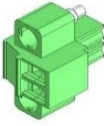
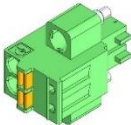
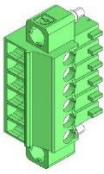
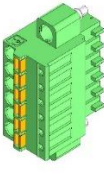
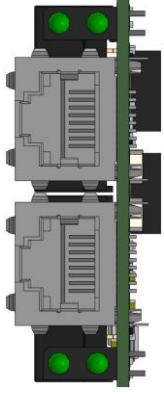
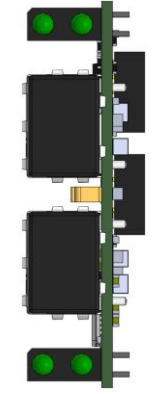
Description of the front panels (display modules) and their technical characteristics are given in the section 6.8.

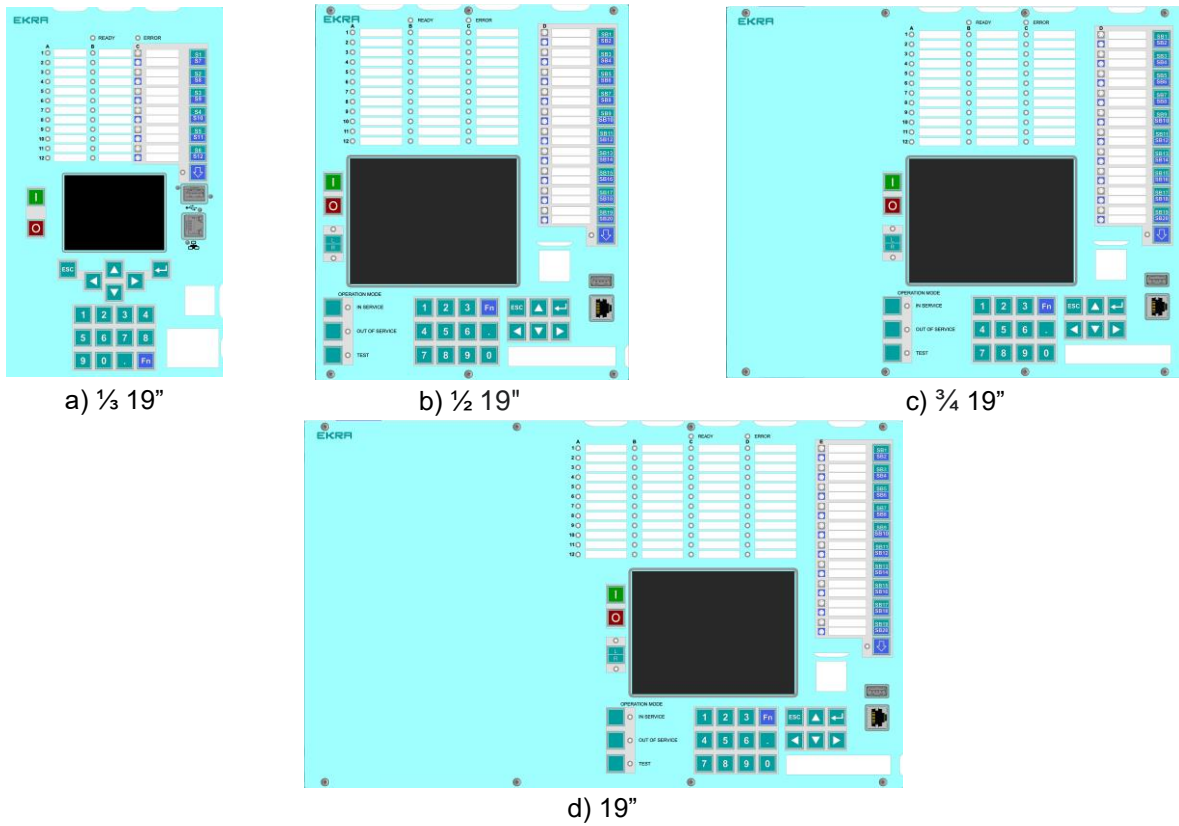

Figure 8 – Appearances of front panels

5.9 General view, dimensions and weight

5.9.1 General view, overall, installation dimensions of the ED2 devices of 1/3 19" design are shown in figure 9.

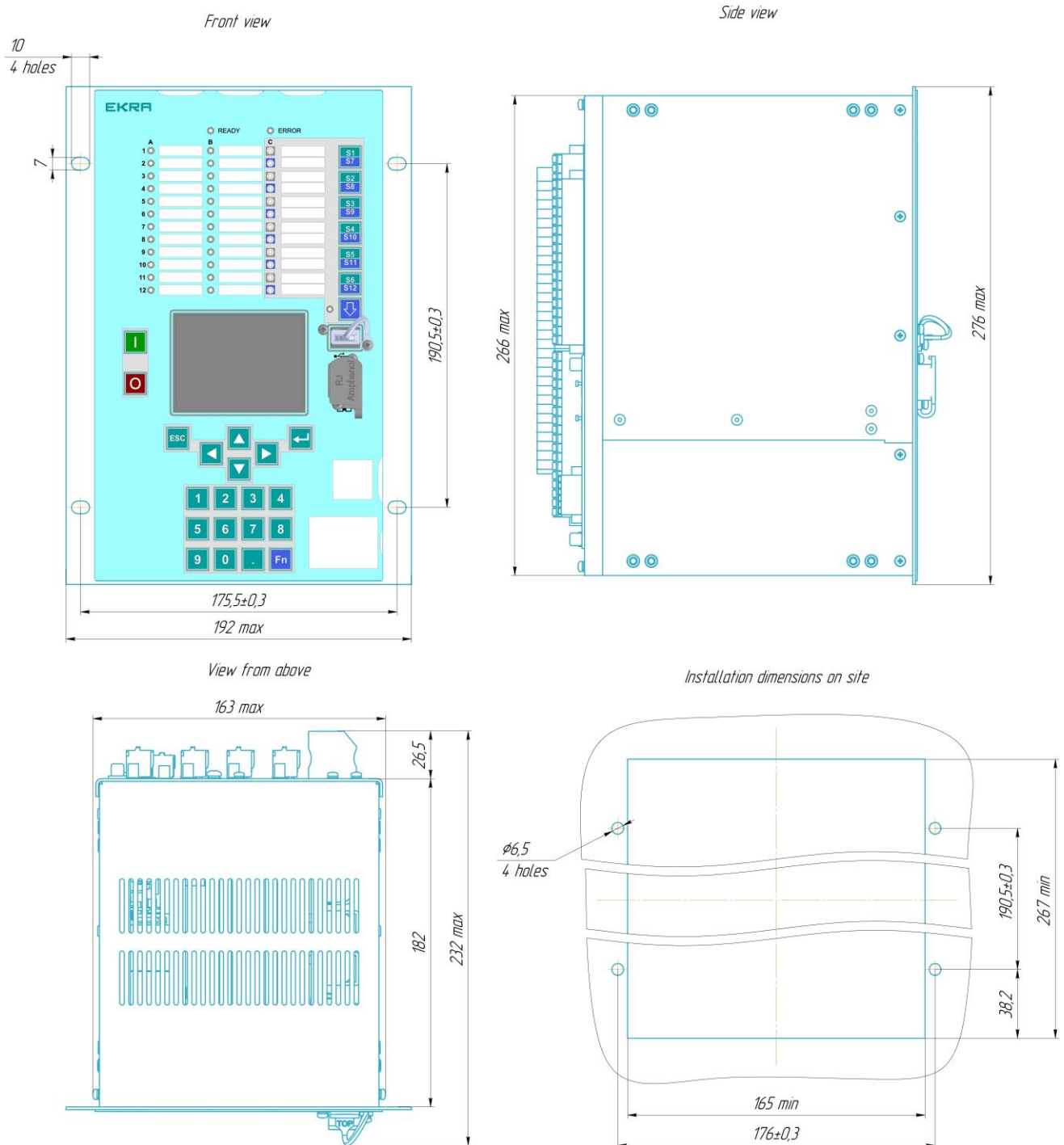

Figure 9 – General view, overall and installation dimensions of the ED2 devices of 1/3 19" design

5.9.2 General view, overall, installation dimensions of the ED2 devices of ½ 19" design are shown in figure 10.

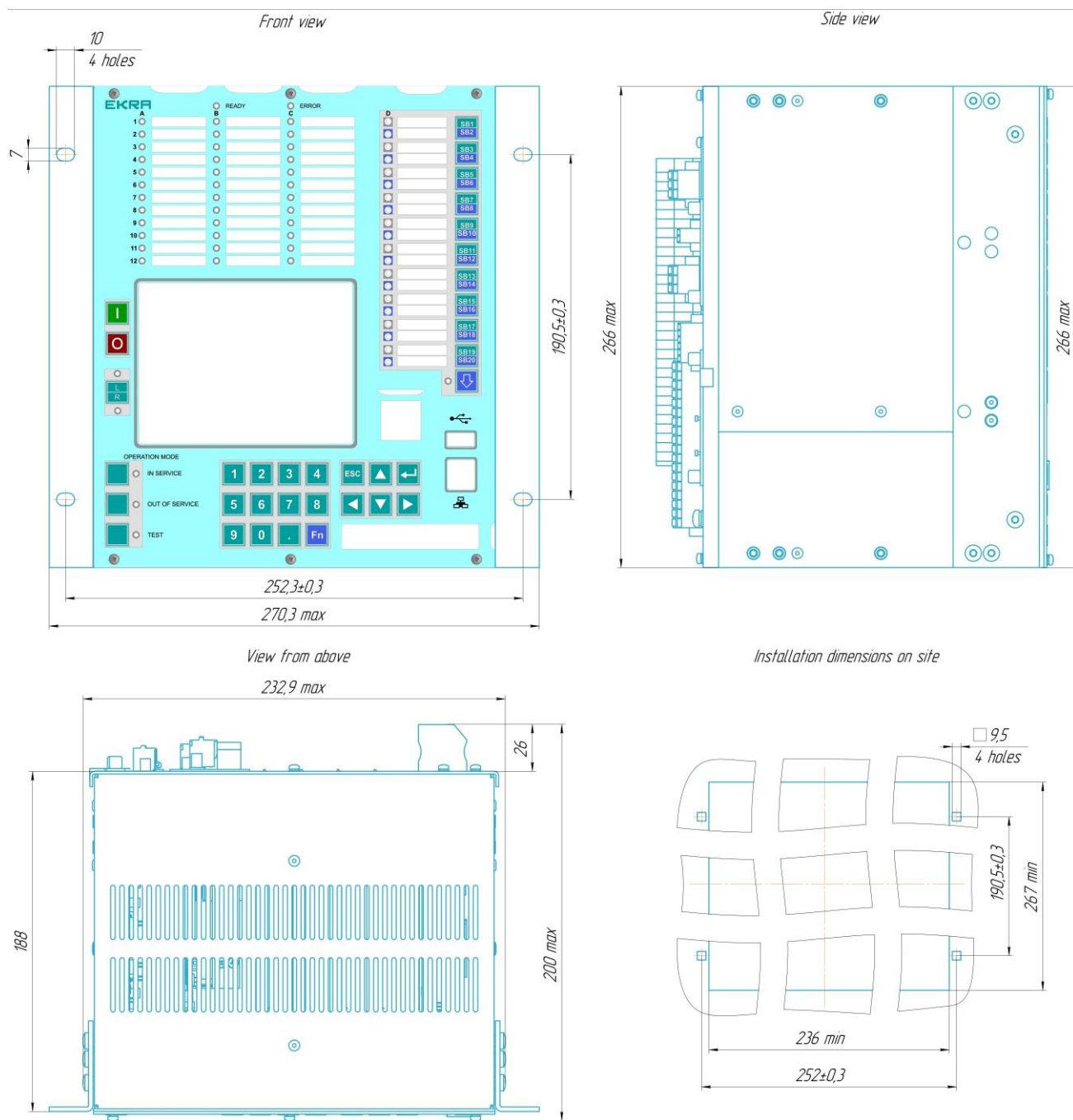

Figure 10 – General view, overall, installation dimensions of the ED2 devices of ½ 19" design

5.9.3 General view, overall, installation dimensions of the of the ED2 devices of ¾ 19" design are shown in figure 11.

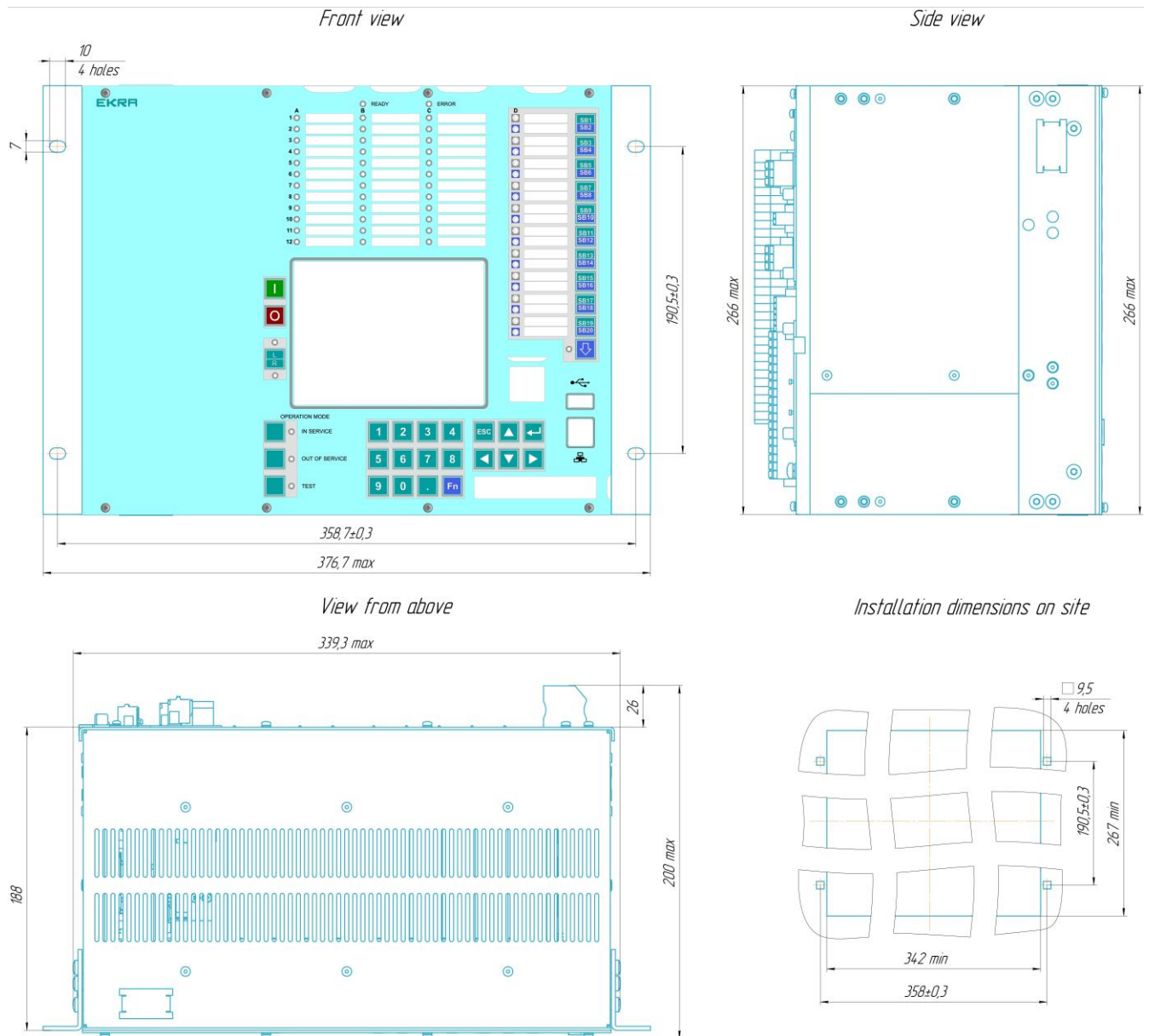

Figure 11 – General view, overall, installation dimensions of the ED2 devices of ¾ 19" design

5.9.4 General view, overall, installation dimensions of the ED2 devices of 19" design are shown in figure 12.

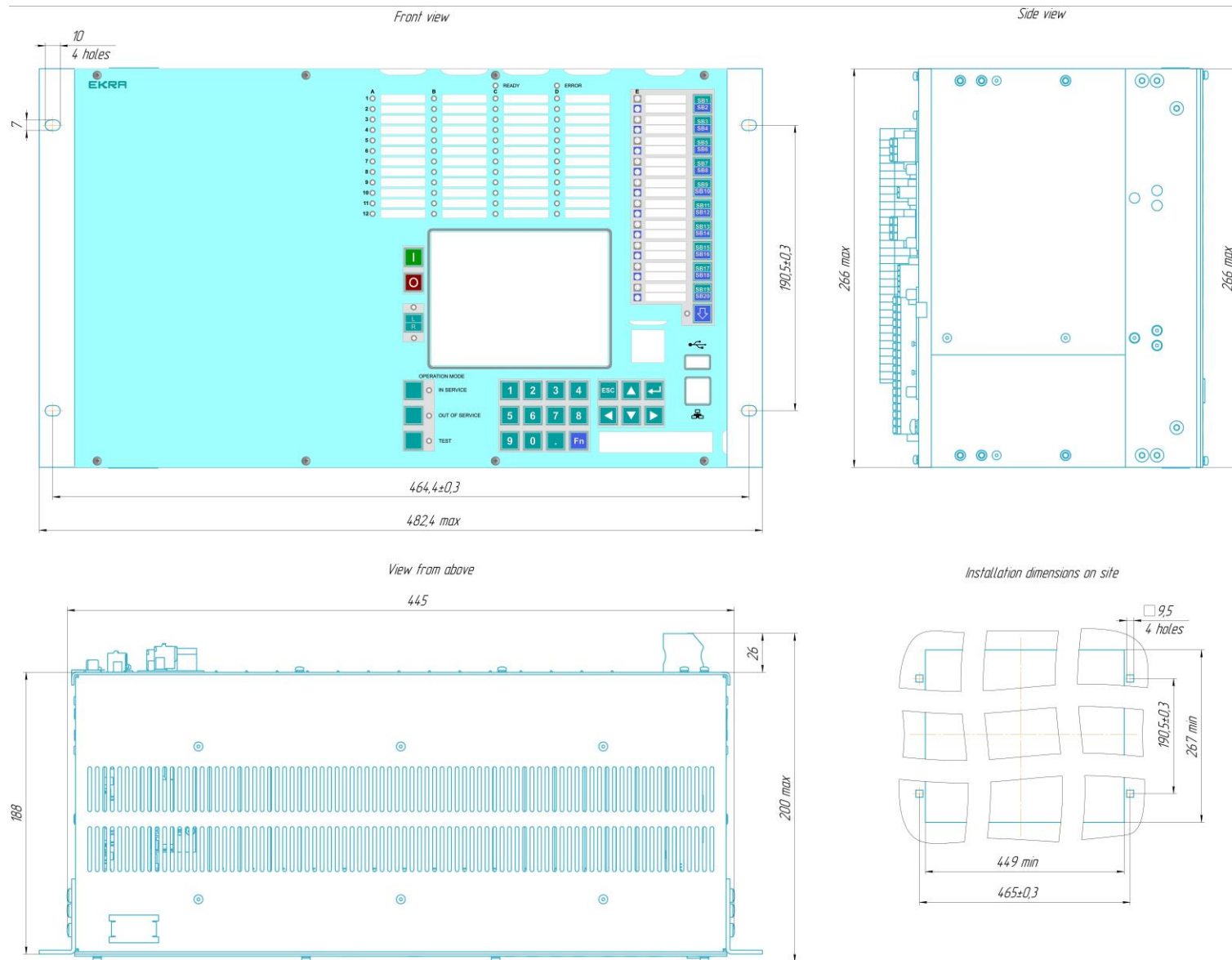

Figure 12 – General view, overall, installation dimensions of the ED2 devices of 19" design

5.9.5 Generalized data on overall dimensions and weight of the device are given in the table 24.

Table 24 – Dimensions and weight of the device

Device type	Width, mm	Height, mm	Depth, mm	Weight, kg, max
1/3 19" design	163.0	266,0	200,0	8
1/2 19" design	232.9			11
3/4 19" design	339.3			16
19" design	445.0			19

6 Device modules

6.1 Logic module

The logic module performs the functions of digital processing, filtering and protection algorithms. Provides control of analog and digital signal converters via data bus 1 (see figure 2). Input and output signals are transmitted through the same bus, and all modules of the device are powered. The connection of the logic module with the indication module (if any) is carried out via data bus 2.

Communication interfaces located in the logic module allow you to exchange information with external digital devices: a personal computer, process control systems, etc.

The logic module is designed as a programmable logic controller. The controller contains a signal DSP processor (function processor), a central HOST processor (communication processor).

The appearance of the logic module and the communication interfaces located on it is shown in the figure 13.

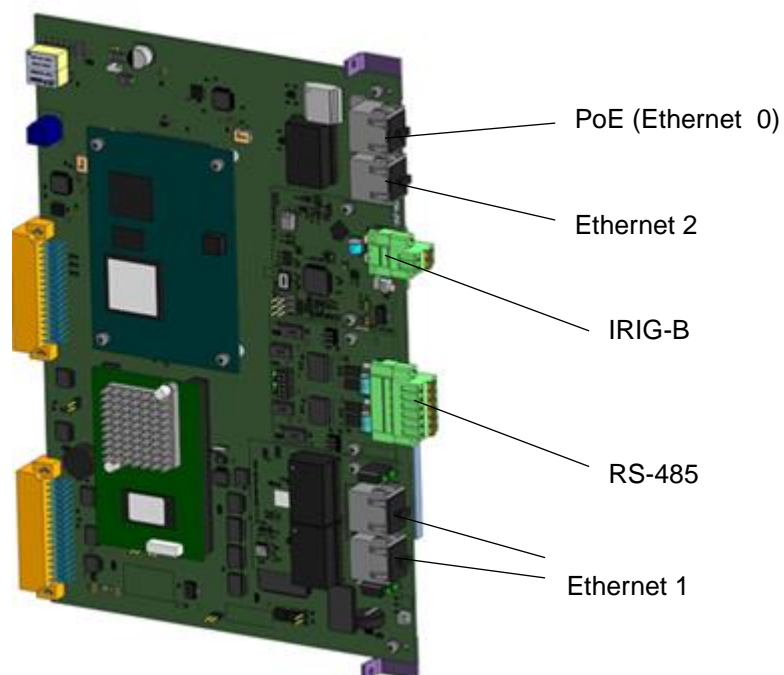

Figure 13 – General view of logic modules

Depending on the version, the logic module can include the following interface units: communication unit 1xEthernet RJ45, communication unit 2xEthernet RJ45, communication unit 2xEthernet LC, time synchronization unit IRIG-B, converter unit 2xTTL – RS-485 (see figure 14).

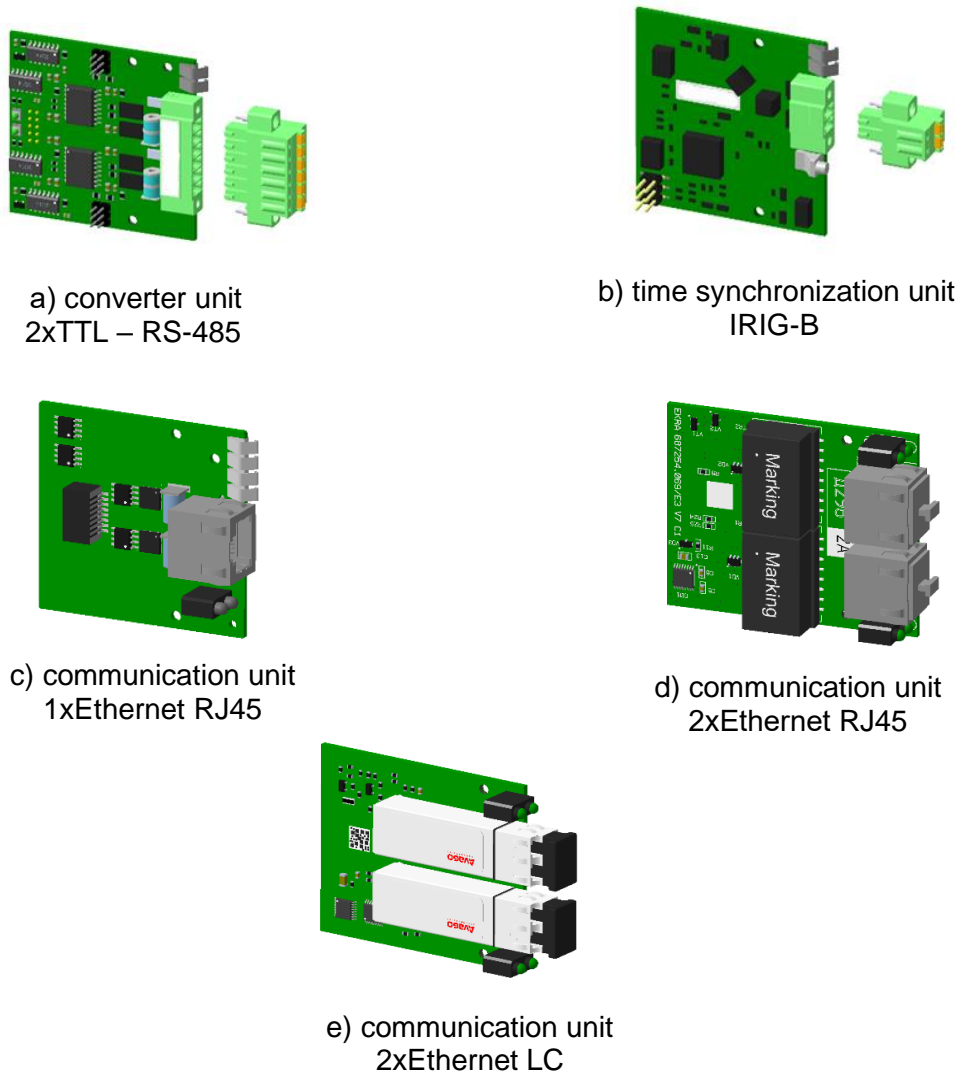

Figure 14 – External views of interface units

The characteristics of the communication and time synchronization interfaces located on the logic module are shown in the table 25.

Table 25 – Characteristics of communication ports and time synchronization of logic module

Interface	Location, destination
Ethernet	<p>For a device with a front panel - Ethernet 0 (electrical: 10/100Base-TX (RJ-45)) – located on the front panel of the device. Performs the functions of the service port required to change the device settings, configuration file and system software version.</p> <p>For a device without a front panel - Ethernet 0 (electrical: 10/100Base-TX (RJ-45), PoE) – located on the rear panel of the device at the top of the logic module. Allows you to connect an external front panel.</p> <p>Ethernet 1 (optical (laser class - I): 100Base-FX (LC) or electrical: 10/100Base-TX (RJ-45)) – located on the rear panel of the device at the bottom of the logic module. Depending on the version, it can have duplicated Ethernet ports in accordance with the requirements of the ISO Ethernet IEEE 802.3 standard with support for PRP redundancy technology and PTP time synchronization.</p> <p>Ethernet 2 (electrical: 10/100Base-TX (RJ-45)) – located on the rear panel of the device in the upper part of the logic module.</p> <p>Ethernet 3 (optical (laser class - I): 100Base-FX (LC) or electrical: 10/100Base-TX (RJ-45)) – located on the rear panel of the device on the module for receiving measurements according to the SV protocol of the IEC 61850-9-2LE standard, has duplicated Ethernet ports in accordance with the requirements of the ISO Ethernet IEEE 802.3 standard with support for PRP redundancy technology and PTP time synchronization.</p> <p>Ethernet interfaces support QoS (IEEE 802.1p) and VLAN (IEEE 802.1Q) mechanisms</p>
RS-485	<p>RS-485-1, RS-485-2 – located on the rear panel of the device in the middle or bottom of the logic module. Carry out data transmission via Modbus RTU and IEC 60870-5-103 protocols. Each port can work with a separate data transfer protocol.</p> <p>The baud rate is available from the following list: 50, 75, 110, 134, 150, 300, 600, 1200, 1800, 2400, 4800, 7200, 9600, 19200, 38400, 57600, 115200 bps</p>
IRIG-B	<p>IRIG-B connector – located on the rear panel of the device for the entire ED2 series.</p> <p>The following timecode formats are supported: IRIG-B003, IRIG-B007</p>

Using these interfaces, the communication and time synchronization protocols can be implemented, shown in table 26.

Depending on the execution, the logic module can support the hardware time synchronization standard: IRIG-B; communication redundancy protocols: LinkBackup (Ethernet Link Redundancy), PRP (Parallel Redundancy Protocol).

NOTICE

In the ED2 series devices, simultaneous operation of the hardware time synchronization ports IRIG-B and PPS is not available.

For more detailed information about communication protocols, methods of time synchronization and communication redundancy, see the document "Communication, time synchronization and network redundancy protocols manual".

Table 26 – List of protocols for data exchange and time synchronization via communication interfaces

Protocol	Communication interface			Time synchronization
	RS-485 ¹⁾	Ethernet	Service port Ethernet	
Modbus RTU	leader or follower	–	–	+
Modbus TCP	–	Client or Server	Server	+
IEC 60870-5-103	leader or follower	–	–	+
IEC 60870-5-104	–	Server		+
IEC 61850-8-1(MMS)	–	Server	–	–
IEC 61850-8-1 (GOOSE)	–	Publisher or Subscriber	–	–
IEC 61850-9-2LE	–	Subscriber	–	–
PTPv2 (standard IEEE1588) ²⁾	–	Client or Server	–	+
SNTP ²⁾	–	Client	–	+
¹⁾ Simultaneous assignment of two or more data exchange protocols to one RS-485 communication interface is not allowed. ²⁾ For time synchronization only.				

To record analog and binary information, a special easily removable non-volatile memory is used – a memory card (Compact Flash Card) with a capacity of up to 64 GB. By default, a 1 GB memory card is installed at the factory. For disturbance recorder devices, the memory card size is 8 GB. The capacity of the installed memory card can be seen in the **Settings** → **System parameters** → **IED parameters** of the Smart Monitor program. The same memory card stores the configuration, including setpoints and device settings, as well as disturbance recorders and an event recorder. By using a memory card, the content can be changed multiple times. The location of the memory card on the logic module is shown in figure 15.

The module is equipped with a real time clock that can be adjusted using software and hardware time synchronization protocols. The real time clock allows you to fix the current time of the recorded events. To save information about the current time when the power is turned off, a lithium battery is provided in the logic module to power the clock (see figure 15).

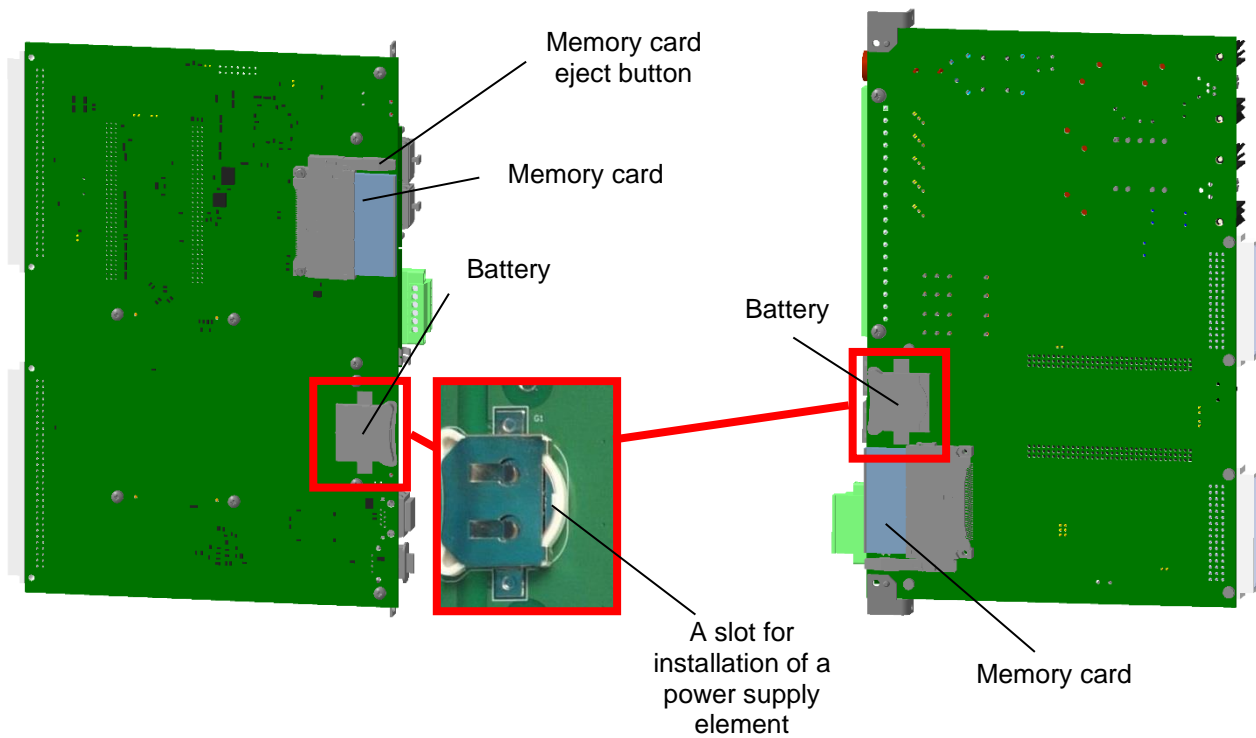

Figure 15 – The arrangement of a power supply element and a memory card in the logic module

The type of battery used in the device is CR2032 with a voltage of 3 V.

An example of the appearance of the rear panel of the logic module with 2×Ethernet RJ45 connectors is shown in the figure 16.

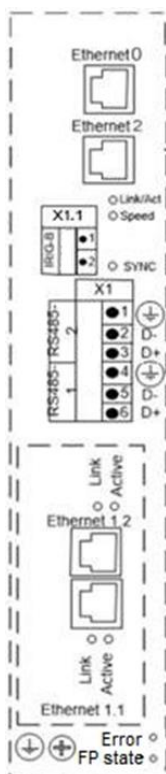

Figure 16 – An example of the appearance of the rear panel of the logic module with 2×Ethernet RJ45

LED indicators on the logic module (rear plate) of the device reflect the actual state of the device and communication ports.

The purpose of the LEDs on the logic module is shown in table 27.

Table 27 – Assignment of LEDs on the logic module

Name	Status signaling	Description
Active	Interfaces Ethernet 1, Ethernet 3	A blinking green LED indicates data transfer via the Ethernet port
Link	Interfaces Ethernet 1, Ethernet 3	A constant green LED indicates that there is a connection to the device by connecting a cable to the Ethernet port
Link/Active	Ethernet 2 interface	A constant green LED indicates that there is a connection to the device by connecting a cable to the Ethernet port. A blinking green LED indicates data transfer via the Ethernet port
Speed	Ethernet 2 interface	A constant green LED indicates that the interface is working in accordance with the 100BASE-TX standard. If the LED does not light up, the interface is working in accordance with the 10BASE-T standard
SYNC.	Synchronization IRIG-B	Periodic (approximately once every 10 seconds) green LED light indicates the reception of data packets using the IRIG-B time synchronization protocol
FP state	Functional processor	LED for diagnostic of the functional processor
FP state /Error	IED	LED for diagnostic of the functional processor and IED malfunction. Flashes green in normal state. Continuous illumination or blinking of the LED in red indicates a IED malfunction
Error	IED	Indicates IED malfunction. Duplicated with the ERROR LED on the front panel of the IED

6.2 Power supply module

The power supply module provides stabilized voltage in all device modules, and also protection of electronic elements from the impact of interferences and power surges.

The module is designed with a power backup function. The function allows you to receive electrical power, either from the main power channel or from a backup one, which increases the reliability of the operation as a whole.

The module contains binary inputs/outputs, as well as an input for PPS pulse hardware time synchronization.

Additionally, the power supply performs the functions:

- receiving binary signals (four inputs with a common point);
- control of the supply voltage of the Binary outputs of the device;
- test relay.

Binary inputs of the power supply module are galvanically isolated from the internal circuits of the device. All binary inputs are connected by a common point (see figure17). Binary inputs of the power supply module can be used as receiving external signals or controlling the operating

mode of the device. The parameters of the binary inputs of the power supply module are identical to the binary inputs of individual modules and are given in the section «Technical data» in Table 4.

The service binary output "Test contact" is used in the mode of automatic testing of the device during commissioning, as well as for testing logic elements with time settings using the EKRASMS-SP software package. This binary output functions in any state of the device when the device is powered.

Service binary output "Life contact" is used to control the lack of voltage "Uout" of the device. Voltage Uout is designed to power all output relays acting in external circuits. Uout is formed in the presence of an acceptable power level, the absence of the "Disable" signal and the absence of an emergency malfunction of the device. In the absence of Uout, the NC contacts of the "Life contact" relay are closed (see figure 17) and power is removed from all output relays (except for the discrete output "Test contact").

The parameters of the binary outputs of the power supply module are given in the «Technical data» section in table 7.

The power supply module implements control of the device status and its serviceability. When an emergency malfunction of the device occurs or it is taken out of the "Operation" mode, the voltage is automatically removed from the output relays of the device to prevent the formation of false output effects.

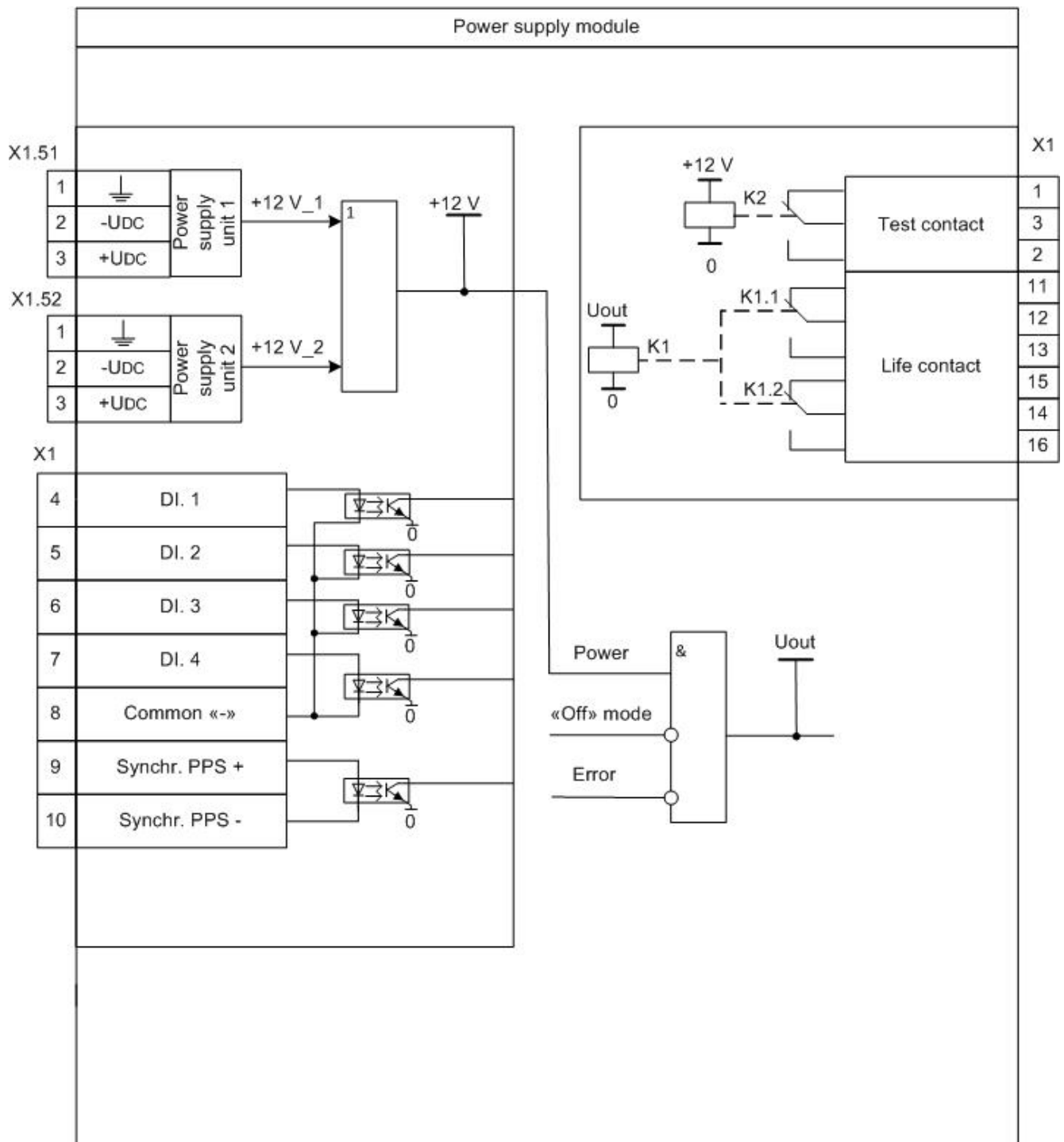
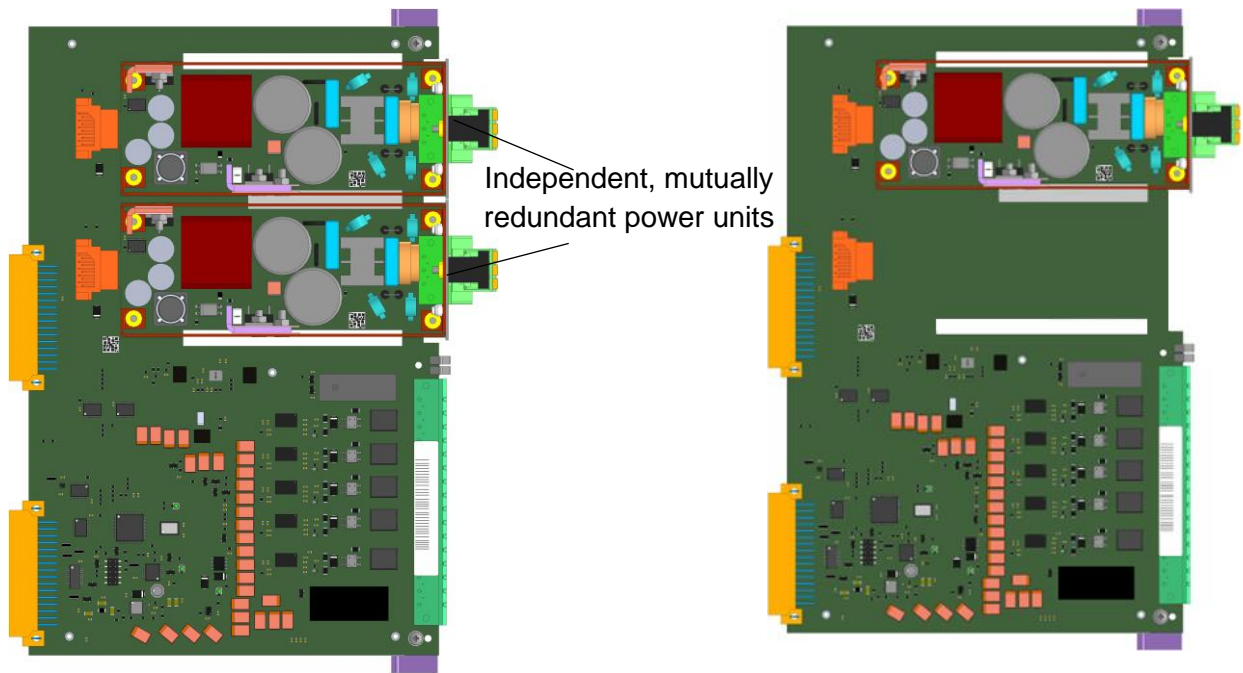

Figure 17 – Structure diagram of the power supply modules

Power supply module versions (see figure 18) are presented in table 28.



a) with two removable power units

b) with one removable power units

Figure 18 – External views of power supplies modules

Table 28 – Versions of power supply modules

Nominal voltage input U_{nom}	Nominal voltage of hardware time synchronization PPS	Quantity of binary inputs, pcs	Quantity of binary outputs, pcs
110 / 125 VDC	24 or 110 / 125 VDC	4 binary inputs (freely configurable)	3 binary outputs – 2 “Error” outputs and 1 “Test” output
220 / 250 VDC	24 or 220 / 250 VDC		

The execution of the power supply module with two mutually redundant independent power supply units allows you to quickly switch power from one unit to another. In this case, the loss and restoration of power from one of the units does not affect the performance of the device.

⚠ WARNING

It is permissible to replace redundant power units without shutting down the device and taking it out of service. But for safety reasons, you must first de-energize the circuits connected to the connector of the module being replaced. The discharge time of the power module capacitors is 25 seconds.

Power supplies module with two mutually redundant power units are constantly powered by only one power unit, while the second remains in a "hot" standby.

6.3 Combined logic and power supply module

This module simultaneously contains a logic module and a power module. Detailed information about logic modules and power modules is provided in the paragraphs above with some differences shown in table 29.

The appearance of the combined logic and power supply module is shown in the figure 19

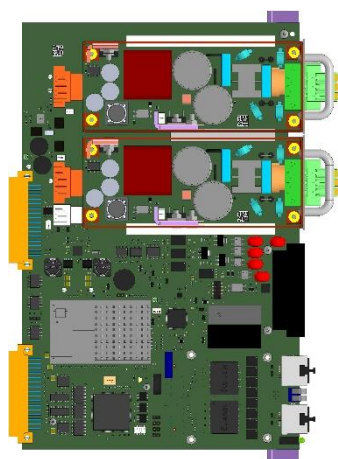

a) combined logic and power supply module with mutually redundant independent power units

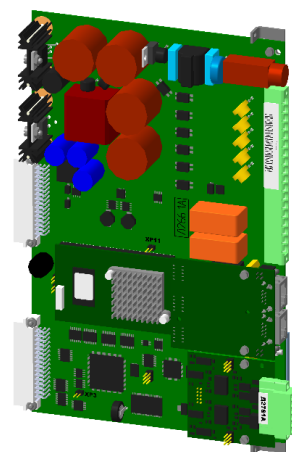

b) combined logic and power supply module without mutually redundant independent power units

Figure 19 – General views of combined logic and power modules

Table 29 – Characteristics of the combined logic and power supply module

Parameter	with redundant supply voltage	No redundant supply voltage
Nominal voltage U_{nom} , V	110 / 125 DC 125 DC 220 / 250 DC	
Removable internal fuse	no	F5AL250V $U_{nom} = 250$ V $I_{nom} = 5$ A Form factor: cylindrical, 5×20mm
Quantity of binary inputs, pcs	4 freely configurable inputs	4 service inputs (non-programmable)
Binary outputs	3 binary outputs – 2 “Error” outputs and 1 “Test” output	
Quantity of RS-485 ports, pcs	no more 2	
Quantity of Ethernet ports, pcs	no more 2	
Port PoE (for connecting a remote display panel)	supported	not supported
Redundancy of Ethernet ports	Link Backup	
Time synchronization IRIG-B	B003, B007	
Nominal voltage of hardware time synchronization PPS, VDC	24; 125; 220	

NOTICE

IRIG-B and PPS hardware time synchronization ports are not available for simultaneous work on ED2 series devices.

The characteristics of the communication and time synchronization ports of the combined logic and power supply module are shown in table 30.

Table 30 – Characteristics of the communication and time synchronization ports of the combined logic and power supply module

Interface	Location, destination
Ethernet	<p>Ethernet 0 (electrical: 10/100Base-TX (RJ-45)) – located on the front panel of the device. Performs the functions of the service port required to change the device settings, configuration file and system software version;</p> <p>Ethernet 1 (electrical: 10/100Base-TX (RJ-45)) – located on the rear panel of the device at the bottom of the logic module;</p> <p>Ethernet 2 (electrical: 10/100Base-TX (RJ-45)) – located on the rear panel of the device at the bottom of the logic module;</p>
RS-485	<p>RS-485-1, RS-485-2 – located on the rear panel of the device in the middle or bottom of the logic module. Carry out data transmission via Modbus RTU and IEC 60870-5-103 protocols. Each port can work with a separate data transfer protocol.</p> <p>The baud rate is available from the following list: 50, 75, 110, 134, 150, 300, 600, 1200, 1800, 2400, 4800, 7200, 9600, 19200, 38400, 57600, 115200 bps</p>
IRIG-B	<p>IRIG-B connector – located on the rear panel of the device for the entire ED2 series.</p> <p>The following timecode formats are supported: IRIG-B003, IRIG-B007</p>
PPS	<p>PPS connector – located on the rear panel of the device for the entire ED2 series.</p> <p>Available signal levels: 24/110/220 V</p>

The parameters of the binary inputs of the combined logic and power supply module are identical to the binary inputs of the individual binary inputs module and are given in the «Technical data» section in table 4.

The parameters of the binary outputs of the combined logic and power supply module are identical to the standard output relays of individual binary outputs module and are given in the «Technical data» section in table 7.

Power supplies with two mutually redundant power units are constantly powered by only one power unit, while the second remains in a "hot" standby.

The location of the connectors and their purpose (rear view) of the combined logic and power supply module are shown in figure 20.

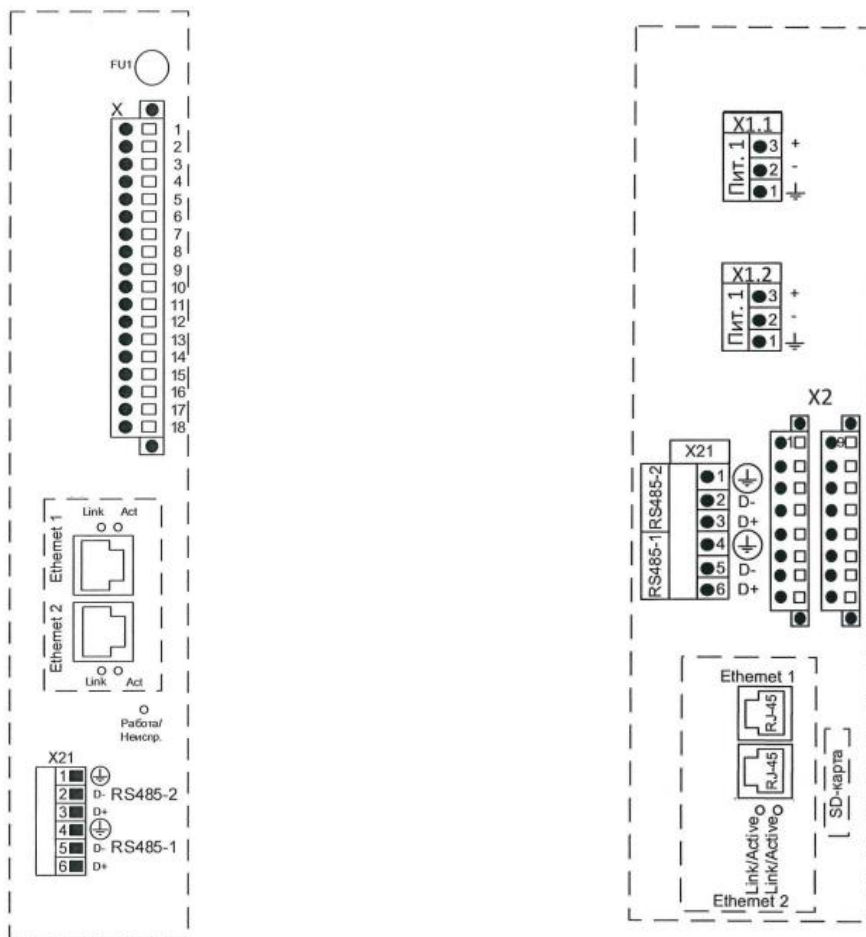

a) combined logic and power supply module without mutually redundant independent power units

b) combined logic and power supply module with mutually redundant independent power units

Figure 20 – External view of the rear panel of the combined logic and power supply module

LED indicators on the combined logic and power supply module (figure 20) of the device reflect the actual state of the device and communication ports.

Assignment of LEDs on the combined logic and power supply module shown in the table 31.

Table 31 – Assignment of LEDs on the combined logic and power supply module

Name	Status signaling	Description
Active	Interfaces Ethernet 1, Ethernet 3	A blinking green LED indicates data transfer via the Ethernet port
Link	Interfaces Ethernet 1, Ethernet 3	A constant green LED indicates that there is a connection to the device by connecting a cable to the Ethernet port
FP state /Error	IED	LED for diagnostic of the functional processor and IED malfunction. Flashes green in normal state. Continuous illumination or blinking of the LED in red indicates a IED malfunction

Structural diagrams of module are shown in the figures 21 – 22.

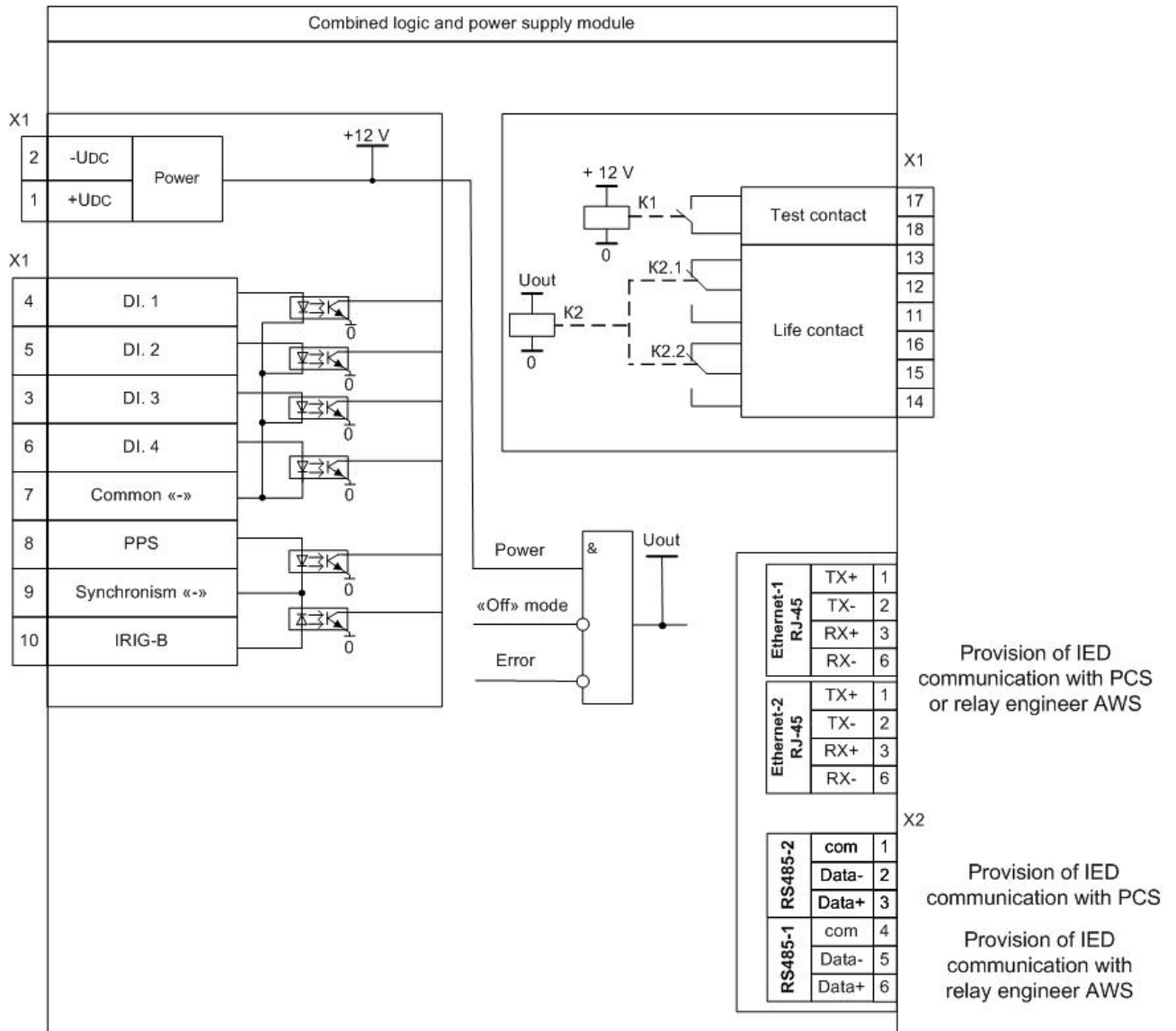
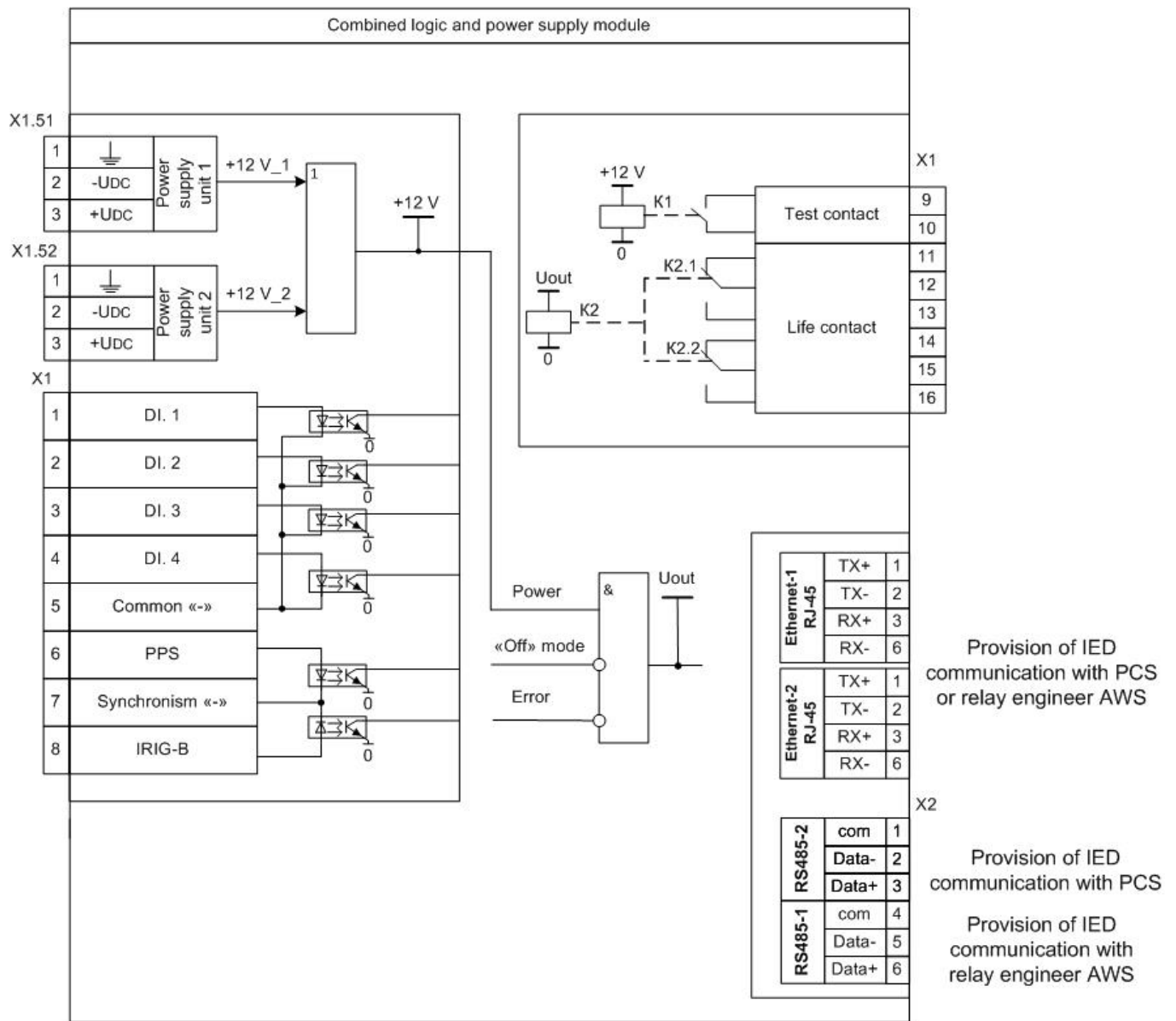

Figure 21 – Structural diagram of the combined logic and power supply module without power redundancy support



Note: instead one of removable power unit, a PoE-supported unit can be installed to connect a remote indication panel

Figure 22 – Structural diagram of the combined logic and power supply module with power redundancy support

6.4 Binary input module

The module contains binary inputs with galvanic isolation from the internal circuits of the device for receiving external signals.

The binary input of DC operates on straight polarity voltage only. Applying reverse polarity voltage to a binary input does not operate at any voltage value.

The unipolarity of the binary input of DC prevents switching of the binary input in the event of earth fault in the negative pole of the auxiliary DC network. A binary input is not damaged when a reverse polarity voltage is applied to it.

For binary inputs, a rejection pulse of at least 200 μC is provided, while a surge current with an amplitude of at least 40 mA is provided.

The general view of the module of binary inputs is shown in figure 23.

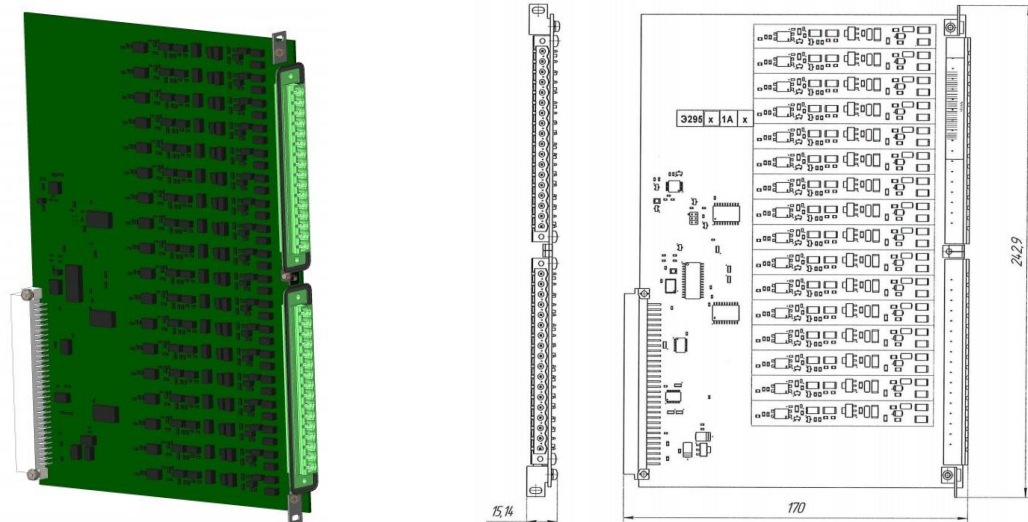

Figure 23 – General view of the module of binary inputs

The binary input block connection diagram is shown in figure 24.

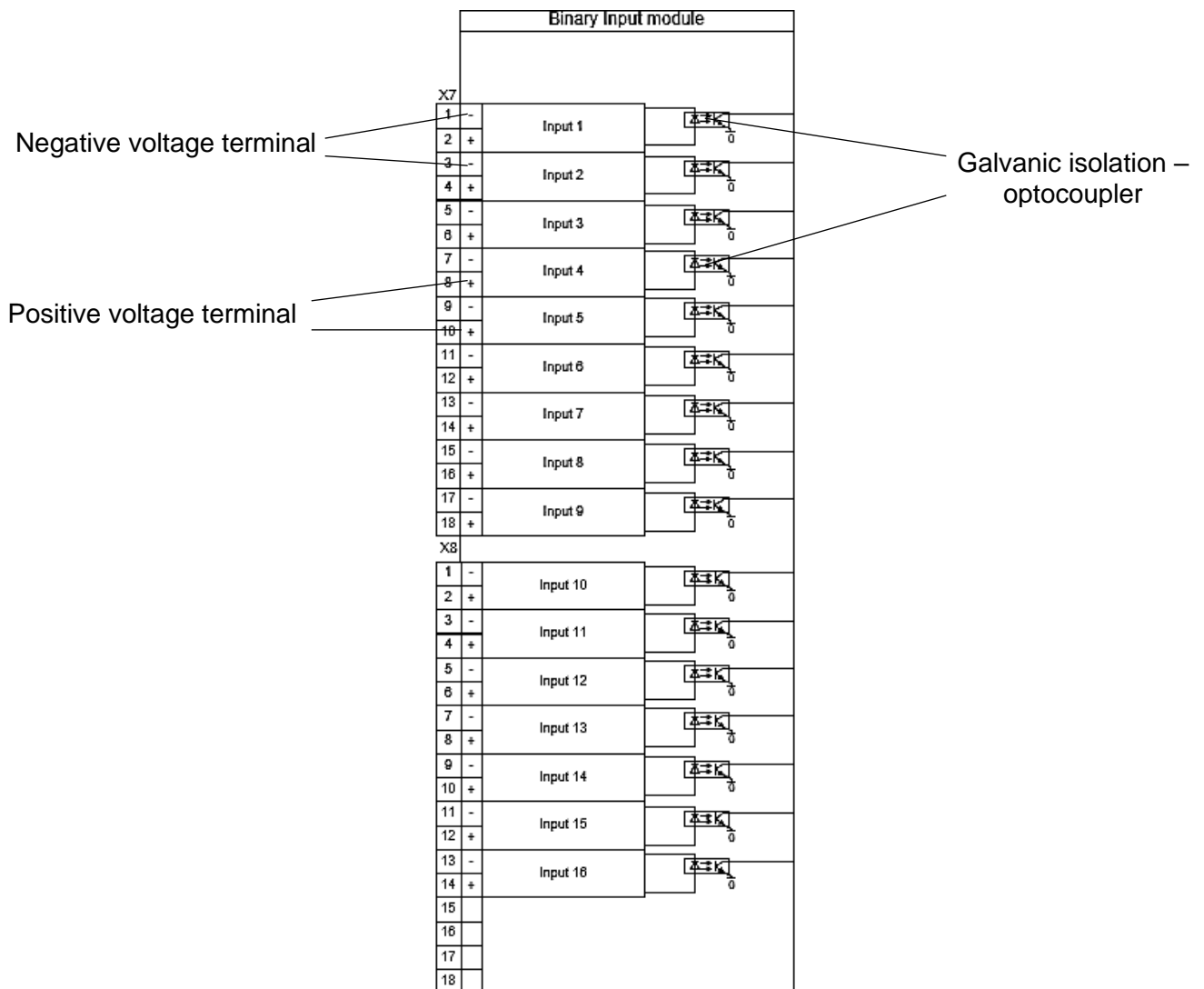

Figure 24 – Connection diagram of the module of binary inputs

Possible versions of the module of binary inputs are presented in table 32.

Таблица 32 – Possible versions of the binary inputs module

Quantity of binary inputs, pcs	Nominal voltages of inputs, V
16	220 / 250 DC
	110 / 125 DC

Characteristics of binary inputs are given in the table 33.

Table 33 – Characteristics of binary inputs

Parameter		Value	
Nominal voltage		110 / 125 VDC	220 / 250 VDC
Control voltage	Uoper, V	82 ± 2	162 ± 2
	Ures, V	75 ± 2	152 ± 2
Power consumption, at nominal voltage, no more		0.8 W	
Current consumption at nominal voltage, not less, mA		2	
Actuation time, ms		5	
Resistance in non-operated state, no more, kOhm		20	
Current impulse when applied Unom, not less		40 mA with a duration of not less than 1 ms at the level of 50 % of the amplitude value	
Maximum allowable voltage		150 VDC	300 VDC
The range of adjustment of technological (including bounce-proof) time delay		from 0 to 9,999 ms with a step of 1 ms	
The frequency of signal inquiry, no more, ms		1.0	

6.5 Binary output module

The module of binary outputs is designed for switching external control and signaling circuits. The module contains output relays, the contacts of which are galvanically separated from the internal circuits of the device. Modules of binary outputs contain output relays, the operation time of which does not exceed 10 ms (standard relays).

Versions of the module of binary outputs differ in the presence/absence of Uout control, the presence of outputs with changeover contacts. Executions of modules of output relays are presented in tables 34.

The general view of the module of binary outputs is shown in figure 25.

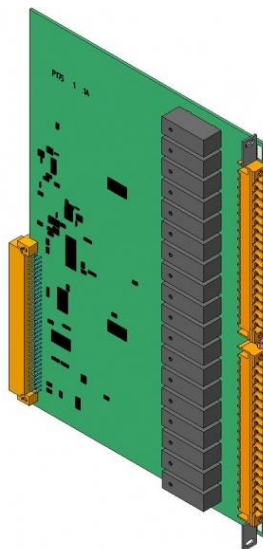

Figure 25 – General view of binary output modules

Table 34 – Versions of modules of binary outputs with standard relays

Type of output relays	Total quantity of logic outputs, pcs	Control of Uout	Quantity of switching relays, pcs	Number of outputs with simultaneous action on two relays, pcs
Standard relay (operation time no more than 10 ms)	16	-	4	-
	16	+	3	-
	16	-	-	2

Technical specification of standard output relays are given in the table 7.

The binary output module connection diagrams are shown in figure 26.

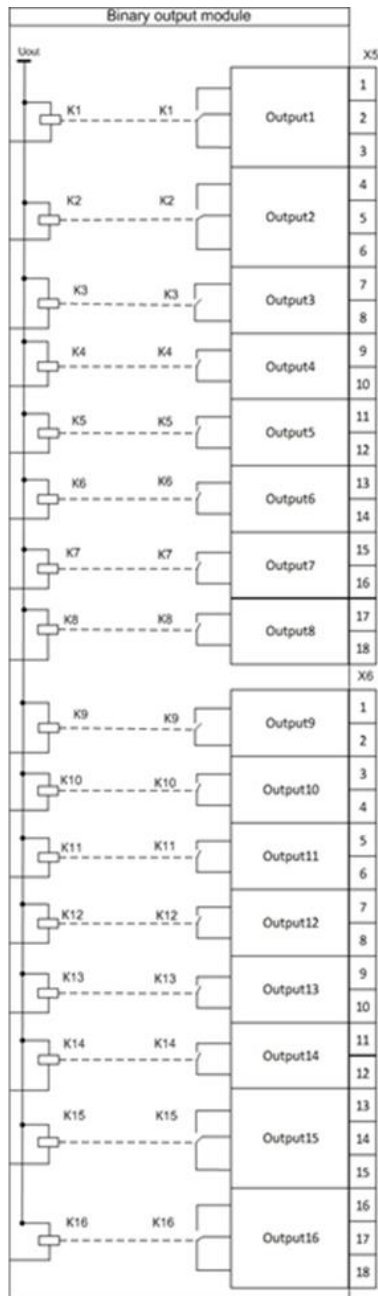

a) module of standard binary outputs

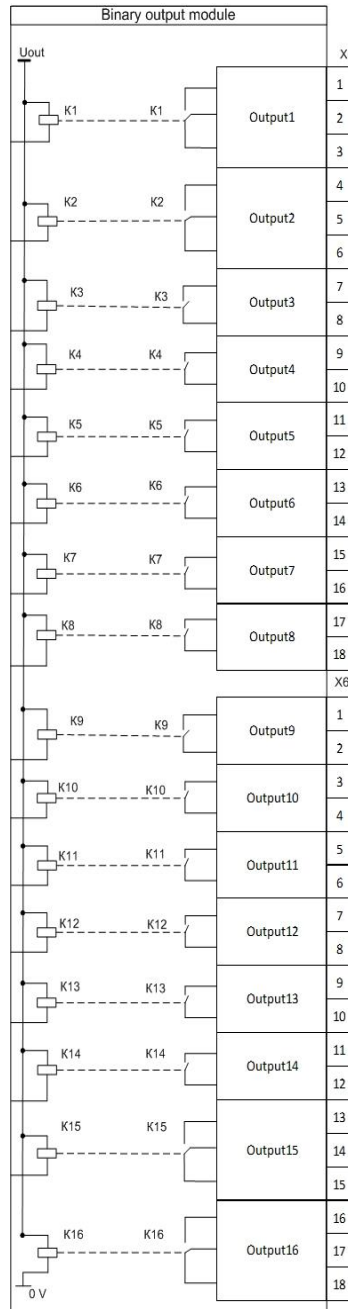

b) module of standard binary outputs with Uout control

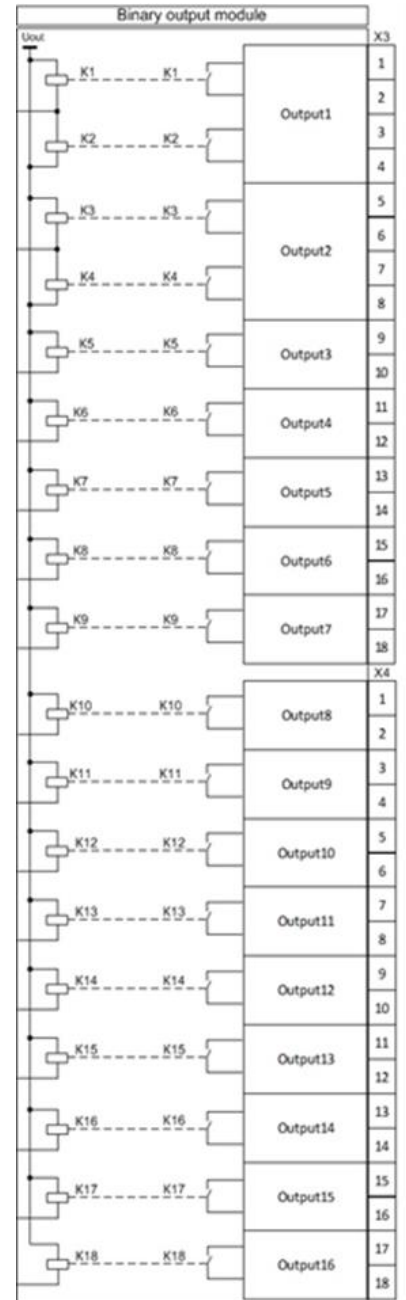

c) module of standard binary outputs with simultaneous action of the first two outputs on two relays

* In figure b) relay K16 is not configurable and is used to control malfunction/out of service of ED2 device.

Figure 26 – Connection diagrams of binary output modules

6.6 Combined binary I/O module

The binary I/O module receives binary signals from external devices and switches external control and signaling circuits.

The general view of the combined binary I/O module is shown in figure 27.

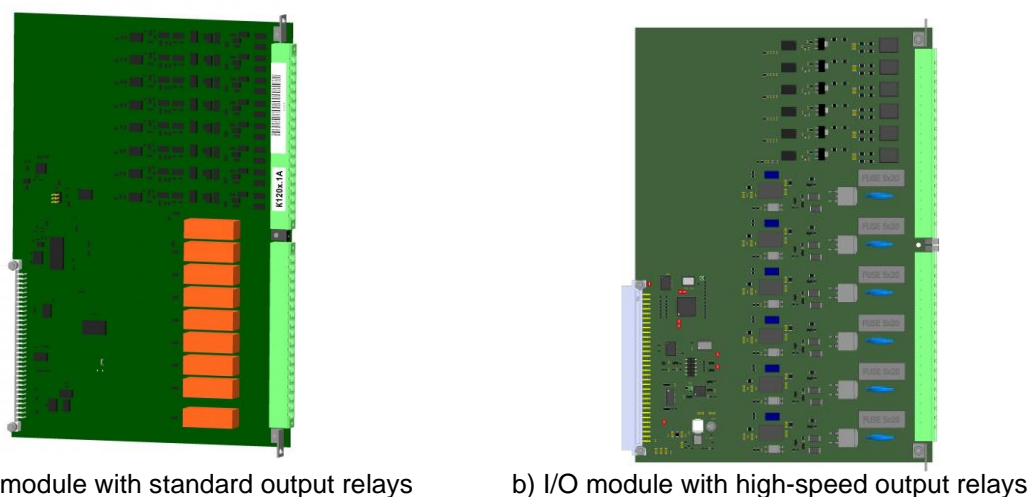

Figure 27 – General view of the binary I/O module

The connection diagrams of the binary I/O output modules are shown in figure 28.

The combined I/O module can contain 8 standard output relays and 8 binary inputs or 6 high-speed output relays and 6 binary inputs.

The versions of modules of combined inputs/outputs given in table 35.

Table 35 – Versions of modules of combined inputs/outputs

Nominal voltages of inputs, V	Quantity of binary inputs, pcs	Quantity of binary outputs, pcs	Control of Uout	Quantity of switching relays, pcs	Number of outputs with simultaneous action on two relays, pcs
220/250 DC	8	9 – standard relays (relays K1 и K2 have one control action see figure 27 a) и b))	-	2	1
	8		+	1	1
110/125 DC	8		-	2	1
	8		+	1	1
220/250 DC	6	6 – high-speed relays	-	-	-
110/125 DC	6		-	-	-

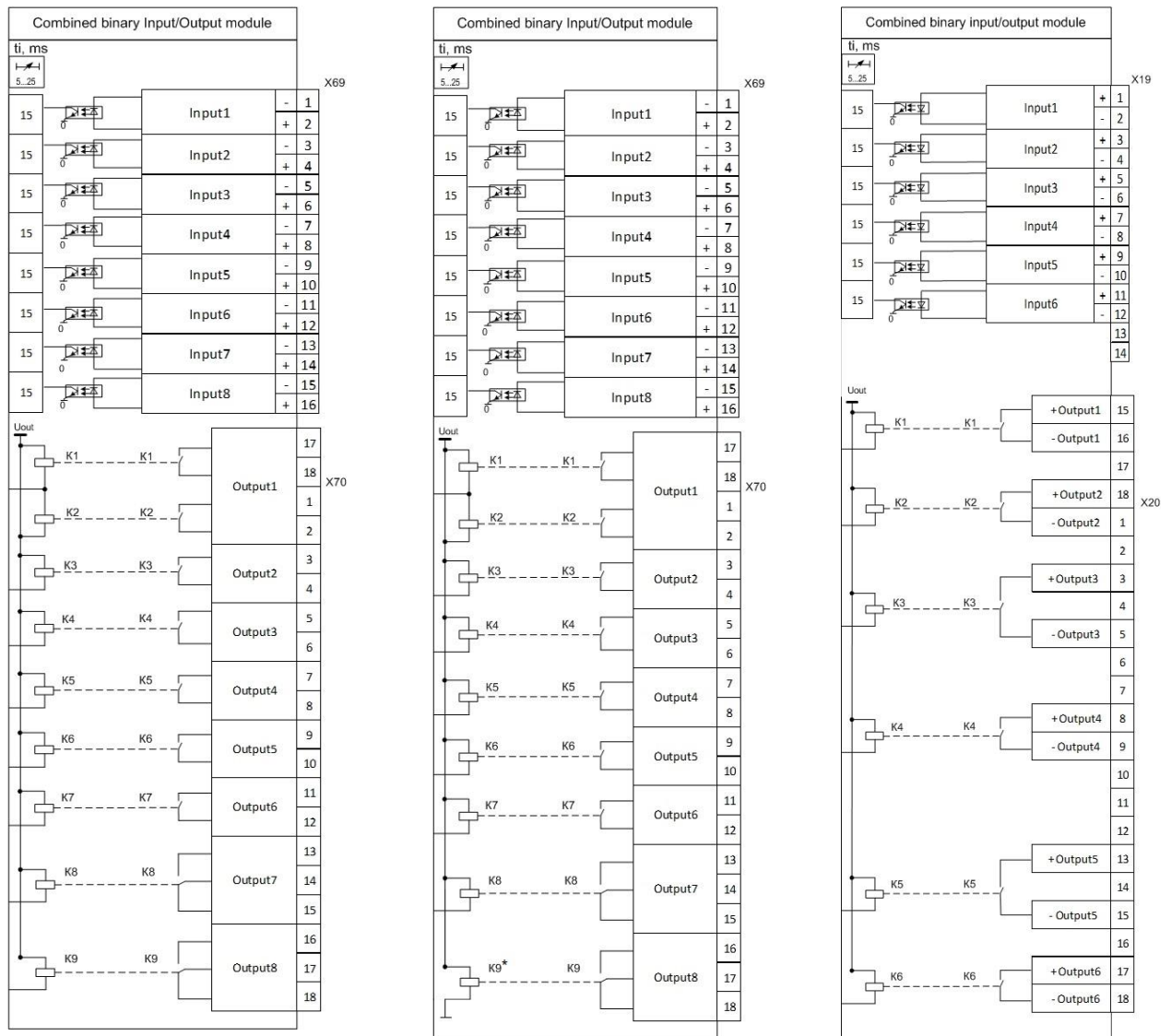

a) I/O module with standard output relays

b) I/O module with standard output relays and Uout control

c) I/O module with high-speed output relays

* In figure b) Relay K9 is not configurable and is used to monitor the health of the device.

Figure 28 – Connection diagram of the binary I/O module

The parameters of the binary inputs of the combined I/O module are identical to the binary inputs of the individual modules and are shown in table 33.

The parameters of the standard binary outputs of the combined I/O module are identical to the output relays of the individual modules and are given in table 7. The parameters of the high-speed binary outputs of the combined I/O module and are given in table 8.

6.7 Analog input module

The analog input module is designed to convert input analog signals of current and voltage into binary data and transfer them to the logic module for further processing.

Main types of analog input modules:

- transformer modules;
- transformerless modules;
- transformer modules with frequency filters for analog inputs.

6.7.1 Transformer modules of analog inputs

Transformer modules of analog inputs are intended for receiving signals from relay or measuring transformers of alternating current and voltage.

The appearance of the transformer module of analog inputs is shown in the figure 29.

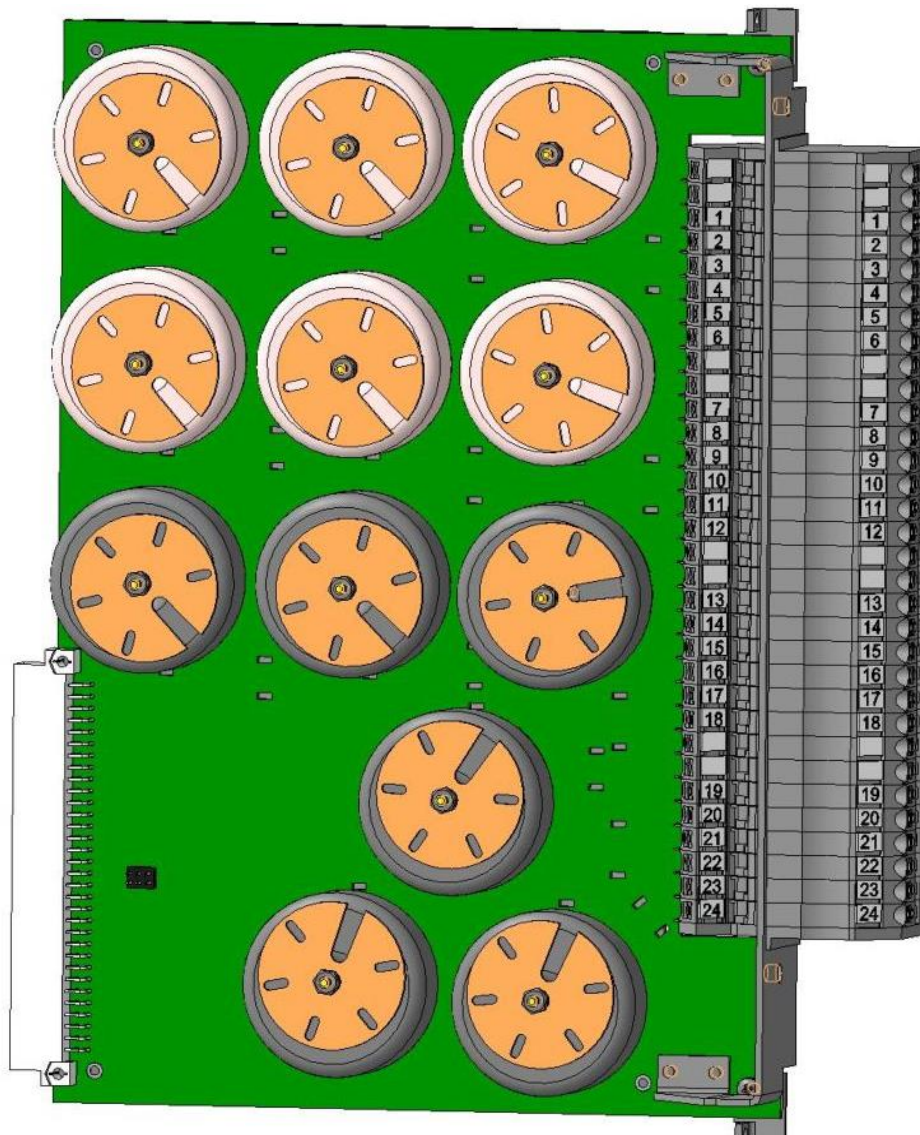

Figure 29 – Appearance of the transformer module of analog inputs

Executions of transformer modules of analog inputs (indicated in the order card or at the request of the customer) are presented in table 36.

Table 36 – Versions of the module of transformer analog inputs

version	Transformer №											
	1	2	3	4	5	6	7	8	9	10	11	12
1	1	2	3	4	5	6	7	8	9	10	11	12
2	CT	VT	VT	VT	VT	VT	VT	VT	VT	VT	VT	VT
3	CT	CT	VT	VT	VT	VT	VT	VT	VT	VT	VT	VT
4	CT	CT	CT	VT	VT	VT	VT	VT	VT	VT	VT	VT
5	CT	CT	CT	CT	VT	VT	VT	VT	VT	VT	VT	VT
6	CT	CT	CT	CT	CT	VT	VT	VT	VT	VT	VT	VT
7	CT	CT	CT	CT	CT	CT	VT	VT	VT	VT	VT	VT
8	CT	CT	CT	CT	CT	CT	CT	VT	VT	VT	VT	VT
9	CT	CT	CT	CT	CT	CT	CT	CT	VT	VT	VT	VT
10	CT	CT	CT	CT	CT	CT	CT	CT	CT	VT	VT	VT
11	CT	CT	CT	CT	CT	CT	CT	CT	CT	CT	VT	VT
12	CT	CT	CT	CT	CT	CT	CT	CT	CT	CT	CT	VT
13	CT	CT	CT	CT	CT	CT	CT	CT	CT	CT	CT	CT
14	VT	VT	VT	VT	VT	VT	VT	VT	VT	VT	VT	VT
15	CT	CT	CT	CT	CT	CT	VT	VT	VT	-	See table 37	
16	CT	CT	CT	CT	CT	CT	VT	VT	VT	-		
17	CT	CT	CT	VT	VT	VT	VT	VT	VT	-		

Table 37 – Parameters of specialized inputs of the module of transformer analog inputs

Transformer №		Output №	Version 1	Version 2
11	Terminals 19-20	E11	Unom = 100 V 50 Hz, Measuring range 2 - 264 V	
		E13 filter	Unom = 60 V 25 Hz, Measuring range 0.5 – 130 V	Unom = 2.5 V 25 Hz, Measuring range 0.3 – 100 V
12	Terminals 21-22	E12	Inom = 0.05 A 50 Hz, Measuring range 0.005 - 2 A	
		E14 filter	Inom = 0.2 A 50 Hz, Measuring range 0.001 – 0.5 A	Inom = 0.01 A 25 Hz, Measuring range 0.001 – 0.4 A
	Terminals 23-24	E12	Inom = 0.15 A 50 Hz, Measuring range 0.015 - 6 A	
		E14 filter	Inom = 0.6 A 50 Hz, Measuring range 0.003 – 1.6 A	Inom = 0.03 A 25 Hz, Measuring range 0.003 – 1.2 A

Examples of the connection diagram of transformer modules of analog inputs shown in figure 30.

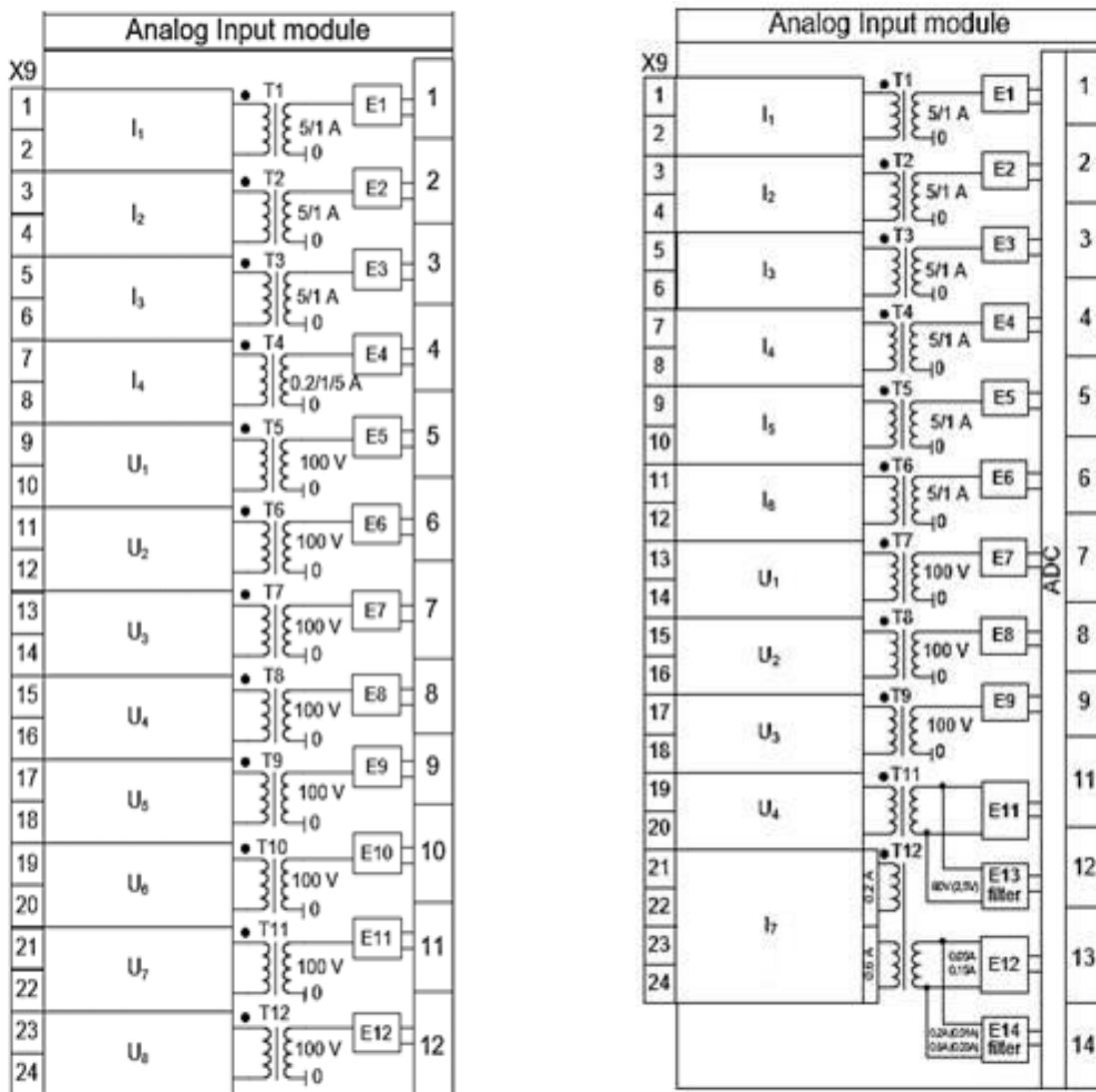

a) transformer module of analog input (4 CT и 8 VT)

b) transformer module of analog input with specialized inputs

Figure 30 – Examples of the connection diagram of transformer modules of analog inputs

Characteristics of analog inputs of AC current and voltage of transformer input modules are presented in tables 38 – 39.

Table 38 – AC current analog input specifications

Parameter		Value	
Rated frequency f_{nom} , Hz		50 / 60	
Frequency range of operation ¹⁾		$f_{nom} \pm 10 \%$	
Nominal current I_{nom} (set by software), A		0.15 / 0.3 / 0.5 / 1.0 / 2.5 / 5.0	
Measurement range		$(0.1 - 40) \cdot I_{nom}$	
Fundamental error of current measurement, no more	Range	$(0.05 - 1.2) \cdot I_{nom}$	$(1.2 - 40) \cdot I_{nom}$
	Value	0.5 %	1.0 %
Complementary error of current measurements from changes in frequency within the operating range, no more		3.0 %	
Power consumption in current circuits at nominal current, no more, VA		0.5	
Thermal resistance		500 A for 1 s 25 A for long duration	
Dynamic load resistance		1,250 A during half the period	
Note – All data on current, voltage and power are indicated as rms values.			

Table 39 – AC voltage analog inputs specifications

Parameter		Value		
Nominal frequency f_{nom}		50 Hz / 60 Hz		
Frequency range of operation ¹⁾		$f_{nom} \pm 10 \%$		
Nominal voltage (set by software), V		100 - 120		
Measurement range, V		0.3 - 264		
Fundamental error of voltage measurement, no more	Range	0.3 – 5.77 V	5.77 – 250 V	250 – 264 V
	Value	1.5 %	0.5 %	1.5 %
Complementary error in measuring voltage from changes in frequency within the operating range, no more		3.0 %		
Power consumption in voltage circuits at nominal voltage, no more, VA		0.1		
Maximum allowable voltage		400 V during 10 s 300 V for long duration		
Note – All data on current, voltage and power are indicated as rms values.				

Notes

1 It is possible to use expanded frequency range from 3 to 95 Hz. Within this range, main protection functions fully maintain their operability. Additional error of current and voltage measurements from frequency alteration does not exceed $\pm 5 \%$. In this case, it is necessary to make certain settings for the analog signals in the configurations. For details, see the document "EKRASMS-SP software package".

2 Application of protection functions in extended frequency range should necessarily be indicated during equipment order.

6.7.2 Transformerless analog input modules

Transformerless modules of analog inputs are designed to receive signals from circuits of process sensors, measuring transducers, etc.

The appearance of transformerless modules of analog inputs is shown in the figure 31.

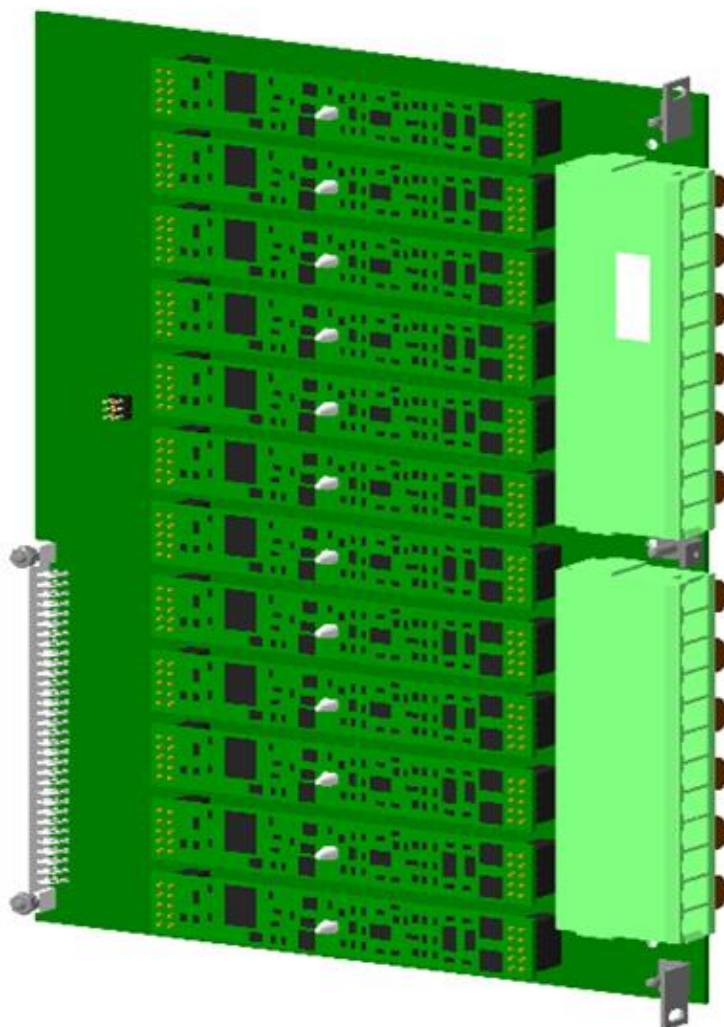

Figure 31 – Appearance of transformerless modules of analog inputs

The module of transformerless analog inputs, depending on the version, supports receiving signals of 1 mA DC, 1 A DC, 100 V AC, 100 V DC 400 V DC with the measurement ranges shown in table 40.

Table 40 – Characteristics of the inputs of the transformerless module

Analog input	Measurement range
1 mA DC	$\pm (0.064 - 32)$ mA
1 A DC	$\pm (0.1 - 50)$ A
100 V AC	(2 - 264) V
100 V DC	from -264 to +264 V
400 V DC	from -600 to +600 V

The connection diagram of the transformerless module of analog inputs is shown in figure 32.

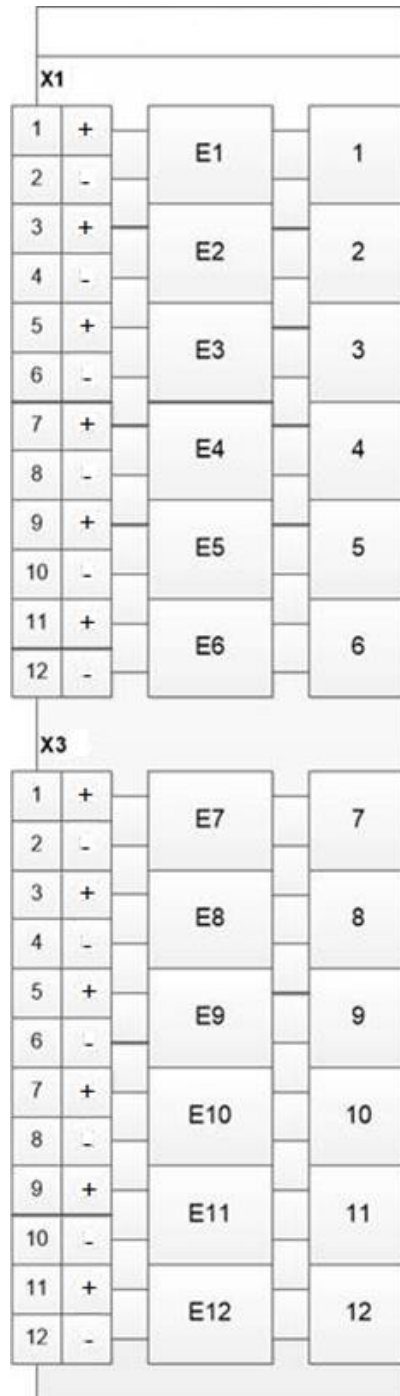

Figure 32 – Connection diagram of the transformerless module of analog inputs

Technical characteristics of the inputs of the transformerless module are given in the tables 41, 42, 43.

Table 41 – DC voltage analog inputs specifications

Parameter	Value	
Nominal voltage, V	100	400
Measurement range, V	± 264	± 600
Fundamental error of voltage inputs, no more	1.5 %	
Power consumption of input at nominal voltage, no more, VA	0.2	
Maximum allowable voltage	300 V for long duration	600 V for long duration

Table 42 – DC current analog inputs specifications

Parameter	Value	
Rated current	1 mA	1 A
Measurement range	± 0.064...± 32 mA	± 0.1...± 50 A
Fundamental error of current inputs, no more	0.15 %;	1.5 %
Power consumption of input at nominal current, no more, VA	0.03	0.15
Thermal resistance	32 mA for long duration	up to 100 A during 1 s; 5 A for long duration

Table 43 – AC voltage analog inputs specifications

Parameter	Value
Nominal voltage, V	100
Measurement range, V	2 – 264
Fundamental error of voltage inputs, no more	1.5 %
Power consumption at nominal voltage, no more, VA	0.2
Maximum allowable voltage	300 V for long duration

6.7.3 Transformer modules with frequency filters for analog inputs

The inputs of the transformer modules with frequency filters inputs are designed to isolate control frequency signals when receiving signals from relay or measuring AC current and voltage transformers.

The appearance of the transformer modules with frequency filters inputs is shown in the figure 33.

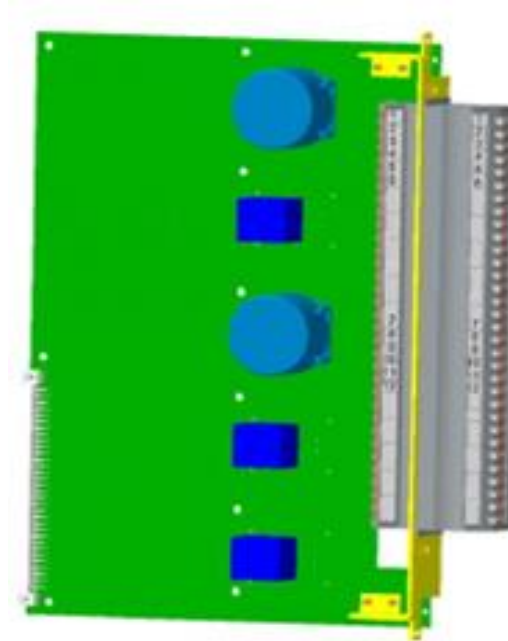

Figure 33 – Appearance of the transformer modules with frequency filters inputs

The connection diagram of the transformer module with frequency filters inputs is shown in the figure 34.

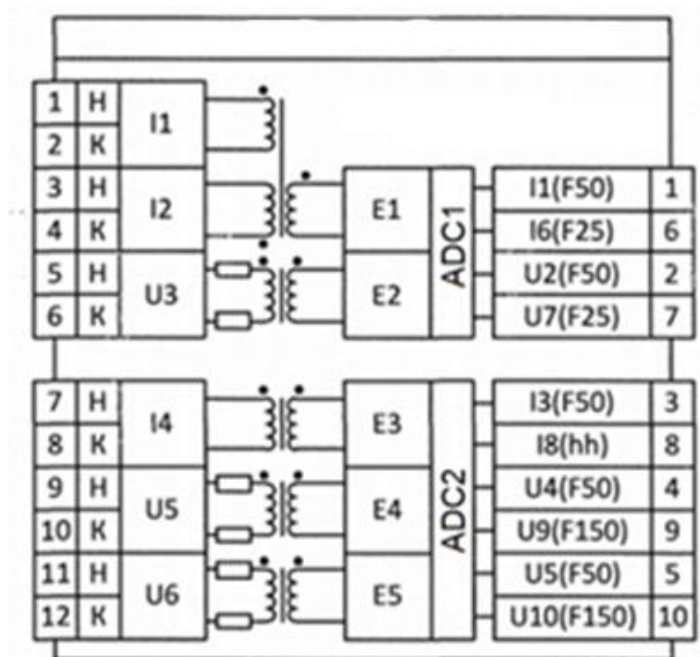

Figure 34 – Connection diagram of the transformer module with frequency filters inputs

The transformer module with frequency filters inputs includes analog inputs for current and voltage (see figure 34).

The analog values I1(F50), U2(F50), I3(F50), U4(F50), U5(F50) are the result of the conversion of filterless circuits that have standard analog input signal processing. The analog values I6(F25), U7(F25), I8(hh), U9(F150), U10(F150) are the result of analog filter circuit conversion. They are designed to isolate control frequency signals and suppress the background signal of industrial frequency.

The characteristics of transformer module with frequency filters inputs are given in tables 44, 45.

Table 44 – Characteristics of transformer module with frequency filters inputs

Parameter		Value
Frequency range of operation ¹⁾		15 – 650 Hz
Measurement range		See table 45
Error of current measurement, no more		3.0 %
Error of voltage measurement, no more		1.0 %
Power consumption in current circuits at 0.1 A, no more, VA		0.001
Power consumption in voltage circuits at 100 V, no more, VA		0.08
Thermal resistance	Current inputs	200 A for 1 s 5 A for long duration
	Voltage inputs	400 V during 10 s 300 V for long duration
Note – All data on current, voltage and power are indicated as rms values.		

Table 45 – Measuring ranges of the inputs of transformer module with frequency filters inputs

Analog input	I1 – I2		U3		I4		U5		U6			
Analog values	I1(F50)	I6(F25)		U2(F50)	U7(F25)		I3(F50)	I8(hh ¹)	U4(F50)	U9(F150)	U5(F50)	U10(F150)
		1	2		1	2						
Measuring range	(0.01 ... 4) A	(0.00002 ... 0.007) A	(0.0001 ... 0.035) A	(0.5 ... 264) V	(0.02 ... 7) V	(0.1 ... 35) V	(0.01 ... 4) A	(0.0004 ... 0.23) A ²	(0.5 ... 264) V	(0.05 ... 24) V	(0.5 ... 264) V	(0.05 ... 264) V
Note: 1 hh – high harmonic. 2 The measurement range of the input signal with a frequency of 150 Hz.												

6.8 Indication module

The indication module is intended for displaying, monitoring the current state, editing settings, checking the operation of the device, and external connection of the device to a computer.

The appearance and arrangement of elements on the indication module are shown in the figures 35, 36.

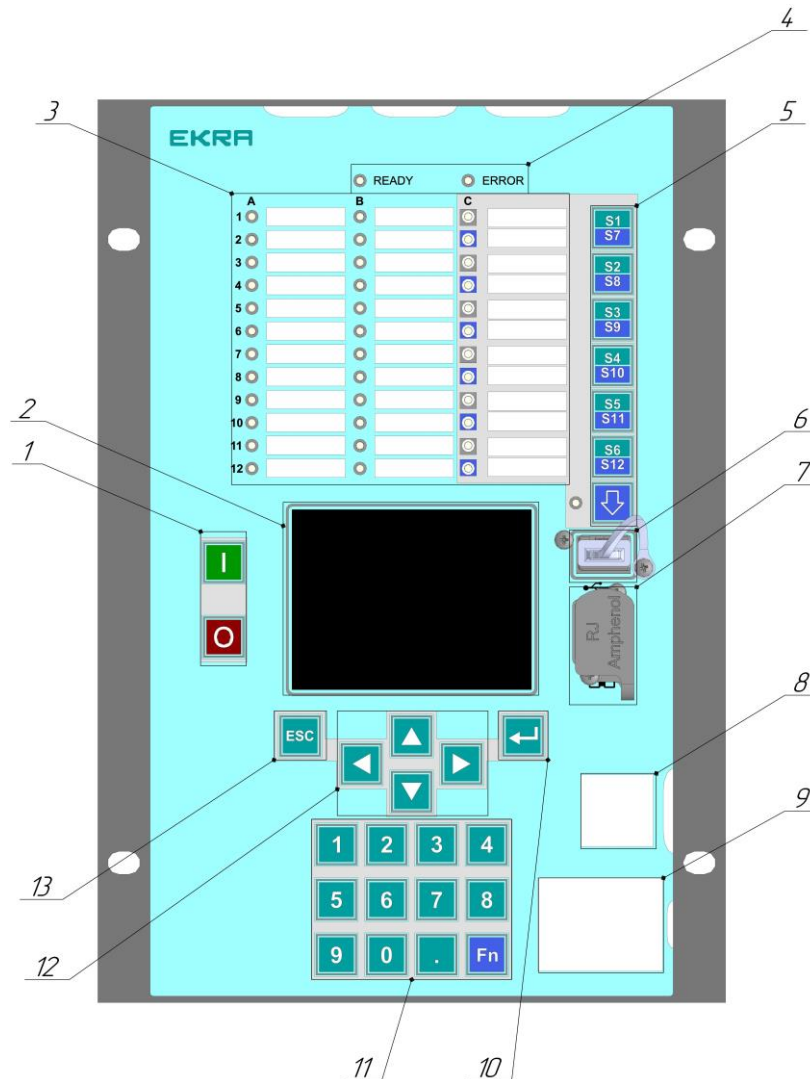

- 1 – circuit-breaker control buttons;
- 2 – graphical display 320x240 dots (diagonal 3.5”);
- 3 – programmable LED indicators with removable name plates;
- 4 – device status LEDs (non-programmable);
- 5 – electronic switches - ES (their presence is determined by the project);
- 6 – USB-flash drive connector;
- 7 – Ethernet service interface (for PC connection);
- 8 – QR code to go to the technical support site;
- 9 – brief information about device type;
- 10 – «ENTER» button;
- 11 – keyboard;
- 12 – cursor control buttons;
- 13 – «ESC» button.

Figure 35 – Arrangement of elements on the indication module 1/3 19"

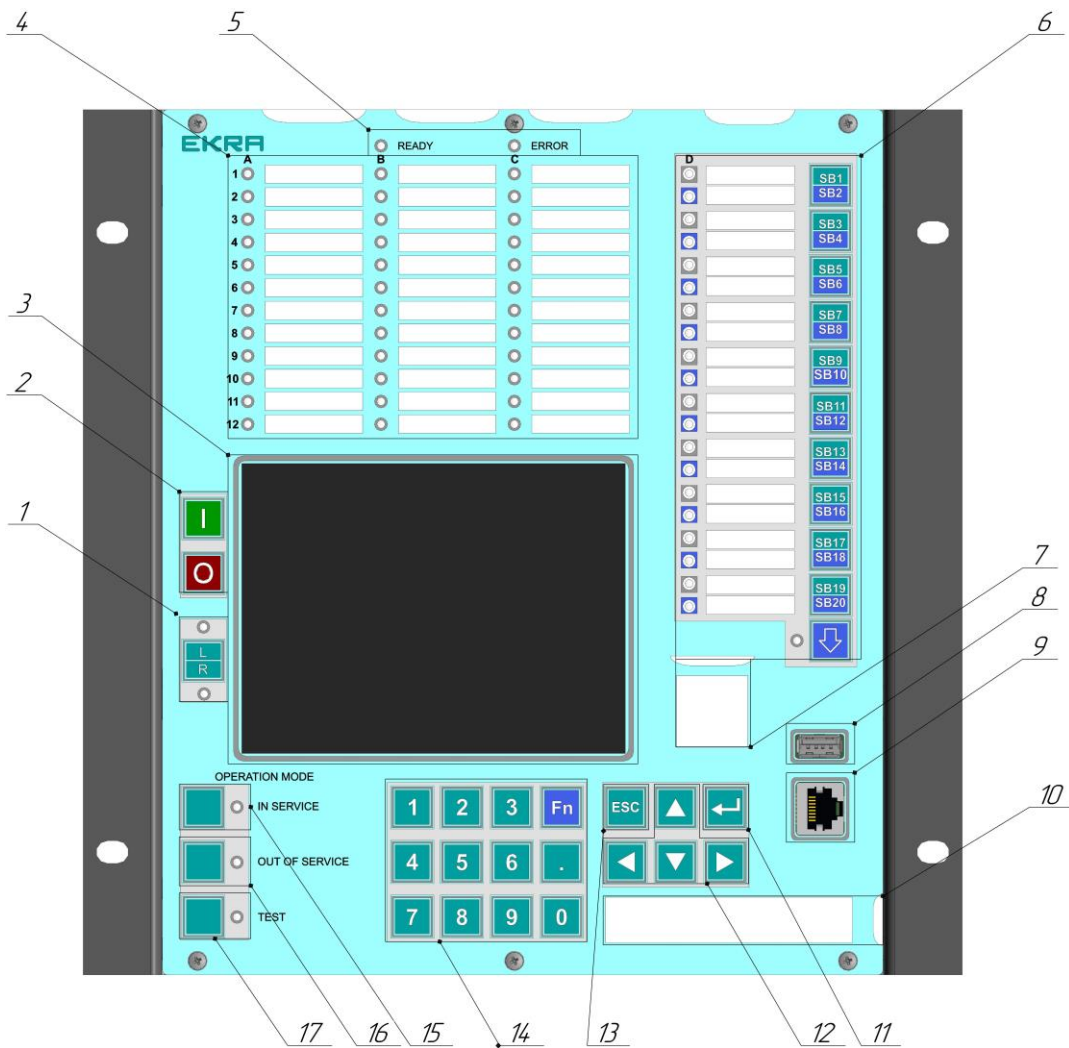

- 1 – local/remote selection button;
- 2 – circuit-breaker control buttons
- 3 – graphical display 320x240 dots (diagonal 5.7")
- 4 – programmable LED indicators with removable name plates;
- 5 – device status LEDs (non-programmable);
- 6 – electronic switches - ES (their presence is determined by the project);
- 7 – QR code to go to the technical support site;
- 8 – USB-flash drive connector;
- 9 – Ethernet service interface (for PC connection);
- 10 – brief information about device type;
- 11 – «ENTER» button;
- 12 – cursor control buttons;
- 13 – «ESC» button;
- 14 – keyboard
- 15 – «In service» button;
- 16 – «Out of service» button;
- 17 – «Test» button.

Figure 36 – Arrangement of elements on the indication module ½ 19"

Note – Purpose of non-configurable LEDs: "Operation", "Fault", indication of the currently active ES group (1 LED, single color).

Table 46 – Indication module parameters

Parameter	Value			
Structural design	19"	¾ 19"	½ 19"	⅓ 19"
Quantity of configurable indicators, pcs ¹⁾	48 (68)	36 (56)	36 (56)	24 (36)
Type of LED indicators	Two-color (red / green)			
Type of LCD indicator	TFT 320x240 (Color, Graphic)			
Size of diagonal LCD indicator	5.7"			3.5"
Electronic switch keys, pcs ²⁾	10(20)	10(20)	10(20)	6(12)
Service Port Connector Type	RJ45			
Service Port Connector Interface	Ethernet 100BASE-TX			
USB port type A to connect a USB-Flash drive	+	+	+	+
Note: 1) in brackets the number of programmable LEDs is indicated in case of non-use of electronic switch keys; 2) in brackets the number of electronic control keys using the «Shift» key.				

The device has programmable two-color (red/green) LEDs for signaling the current state of the device, actuation of protections and automation. Depending on the application, the color of the LED can be customized by the user.

The device has a color TFT display with a resolution of 320x240 with diagonals of 5.7" or 3.5". With the help of the display, the current values of currents and voltages of analog inputs, the state of binary inputs, the values of parameters and settings, as well as a mimic diagram, if available, are displayed.

Electronic control switch (ES) are an analogue of the operational control key and are designed to quickly change the operating modes of the functions of the device. Each ES has its own LED for position indication. If the ES of the device is not configured, then their LEDs can be assigned to the desired effect. The number of ESs depends on the design of the device and is given in table 46.

With the help of control buttons, ED2 is controlled (changing the values of settings and states of electronic switches).

Using the "ESC" and "ENTER" buttons enter / exit the active menu item.

Buttons "I" ("ON") and "O" ("OFF") are designed to control the circuit breaker, if this function is included in the project, otherwise they are blocked.









The L/R button allows you to switch the device operation mode to the "local" and "remote" states, if this function is provided for in the project.

The USB type A connector is intended for connecting a flash card, with which you can update the device configuration and software, download waveforms and reports on settings. For more information on working with the device via USB, see section 8.1.9.

The Ethernet connector is a service connector and is intended for local connection of the device to a PC. This connector is not designed to connect the device to a local network.

Non-programmable LEDs "Ready" and "Fault" are intended only for signaling the current state of the device. Possible LED states and corresponding device states and descriptions are given in table 47.

Table 47 – ED2 device status

LED state	Device status	Function
Ready  Error 	"ON"	<p>A device is in operation status. "ON" is shown in the menu item Diagnostic → IED state in the State line on the device display. The device is in this state when there is no emergency failure and the presence of the "ON" signal from the "ON" electronic switch on the device front panel. The device display can switch to "standby" mode when there is no display glowing</p>
	"TEST"	<p>It is used for complex test of signal routing (real-life signal and signal by communication protocols) from the device to the acknowledgment location, and also for visual test of LED indicators on the device front panel. The transition to the "TEST" mode is carried out in the presence of the "TEST" signal from the "TEST" electronic switch on the front panel of the device. It is also possible to enter the "TEST" mode using the Smart Monitor program, while the device displays a message that the device is in the "TEST" mode</p>
	WARNING "FAILURE"	<p> CAUTION In the "TEST" mode, it is possible to turn off the primary equipment!</p> <p>Small failure, which does not lead to the device disabling. This state is confirmed by the illumination of the service LED "WARNING"</p>
Ready  Error 	EMERGENCY "FAILURE"	<p>The device is out of service and in a failure condition. This state is determined by the presence of hardware or software failures (for example, if the auxiliary supply voltage does not meet the necessary requirements). In this mode, there is a hardware disconnection of the power supply to the windings of the output relays of the device</p>
	"EMULATION"	<p>It is designed to test the device protection logic and it is activated only from the service port of the device. Entering and escaping this status is implemented only via software package "EKRASMS-SP". "ON" in the menu item Diagnostic → IED state in the Emulation line on the device display. In the emulation mode, the power supply to the output relay coils of the device is turned off</p> <p> CAUTION Switch the device to "OFF" status before switching to "EMULATION" mode!</p>
Ready  Error 	"OFF"	<p>The device is in disabled state. In this status, the device output relays windings are off, and all other set device functions are fully performed. The device is in the "OFF" state when there is no emergency failure and the presence of the "OFF" signal from the "OFF" electronic switch on the device front panel</p>

7 System software for ED2 devices

In the general case, the software of ED2 series devices consists of the following types:

- system (internal) software that performs the basic functions of the device. The system software is factory installed;
- applied (external) software designed to organize work with the device, its configuration and setting. The latest up-to-date version of the application software is always available on the manufacturer's website.

The possibility of updating the system and application software is provided. Updating the software may involve adding new functions or improving existing ones, which can improve the performance of the device to some extent. The procedure for updating the system software is described in detail in the "Troubleshooting" section 13.

The system and applied software of the ED2 series devices are constantly updated and improved.

The system software provides continuous self-control, control of the validity of the input information.

System software performs the following basic functions of the device:

- relay protection and/or automation;
- control of connection switching devices and calculation of their remaining life;
- disturbance recorder;
- event recorder;
- communication with the upper level;
- interface of interaction with operating personnel.

The device has a built-in logical part, forming functions in accordance with the device functionality and Customer's requirements. The device performs protection and control functions fully in case there is no communication with the upper level.

Disturbance recording in case of faults starts automatically when the state of the selected signals changes. Due to use of non-volatile memory (memory card), event data base, device settings and parameters are saved when power supply operating voltage disappears.

The device has a factory-defined logic part that cannot be changed and a freely programmable logic part in accordance with IEC 61131-3 (2013). The freely programmable logic part can be edited using the "Configurator" application, which is supplied as part of the software package "EKRASMS-SP".

7.1 Programmable logic (PL)

Programmable logic is a functional module of an IED that provides connections to logic inputs and outputs. The entire logic diagram of the device can be conditionally divided into two parts: non-editable logic and programmable logic.

Non-editable logic is designed and applied (i.e. loaded into a device) at the manufacturer of the device. This logic is the basis for the operation of the device (IED). This logic is represented as closed functional modules. It cannot be changed by the end user, but functional modules' input signals can be configured and output signals can be used in programmable logic.

Programmable logic is the logic programmed by the user of the device. This logic can be modified or created by user. Programmable logic consists of logical and other elements that are used to combine and determine the parameters of the device functions. Logic elements can be programmed for various logic and protective functions.

The device is shipped with a set of factory logic diagrams that cover the main applications of the device; however, the user can change the factory diagrams to build his desired logic. When designing your logic diagram, you can use the factory diagram as a basis for editing.

Figure 37 shows how the logic circuit is connected to the rest of the IED.

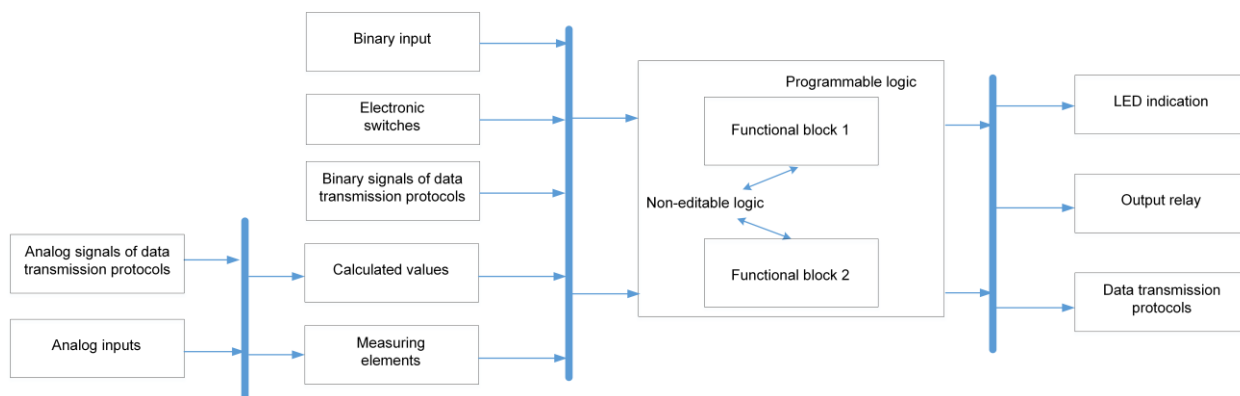

Figure 37 – Conditional structure of the logical part of the ED2 series device

The input quantities for the programmable logic are:

- device binary inputs;
- electronic switch on the front panel of the device;
- signals received via data transmission protocols;
- signals from protection functions;
- signals from calculated values.

The output values of the logic circuit are:

- programmed LEDs on the front panel of the device;
- device output relay;
- data of communication protocols.

Basic logic elements, applicable to the device configuration, their principle of operation and purpose are provided in the document “EKRASMS-SP software package” in the section "Logic elements".

7.2 Event recorder

The device provides continuous registration of changes in the state of all real binary and logical signals with fixation of the date and time of events. The built-in "Event Recorder" function ensures recording of status change of any logical signal, selected from any available protection or logical function of the device. For example, a change in the state of a binary input or operation of a protection element is the reason for an event being recorded in the log. These data can be used to analyze changes in the operating mode of the protected facility. These events are stored in the non-volatile memory of the IED. Each entry has a time stamp of the event.

Event records can be displayed on the front panel of the device, but it is more convenient to view the events using the application software. It allows retrieving the event log from the device and allows saving the data in one file for subsequent analysis on a personal computer (PC).

The capacity of event recorder buffer provides memorizing of up to 7,500 events with resolution capability of 1 ms. When the buffer is full, new information is recorded instead of the oldest recorded information.

The selection and assignment of the registered signals is carried out using the application software, or through the front panel of the device. More details about the selection and assignment of signals are described in the document "EKRASMS-SP software package".

7.3 Disturbance recorder

The device provides a function of emergency disturbance recording of analog, binary inputs, logical signals and calculated values from the device functions when the state of any available binary input or from a signal received as a result of logical operations, changes.

Disturbance records are stored in the device in proprietary format (*.aNNN) and in COMTRADE 2013 format (*.cfg, *.dat, *.hdr).

The duration of disturbance record is determined by the time of saving start conditions and settings as per record time, which enable to determine time of recording pre-fault, fault, and post-fault modes, and also limit record time when the start signal is held in the active state for a long time.

Logical signals, selected for starting, are combined according to the scheme "OR" to form a start signal.

In case if a start signal is in the active state for a long time, a disturbance recorder remains in the mode of disturbance recording not longer than it is set by the setting of the record duration limit (see figure 38).

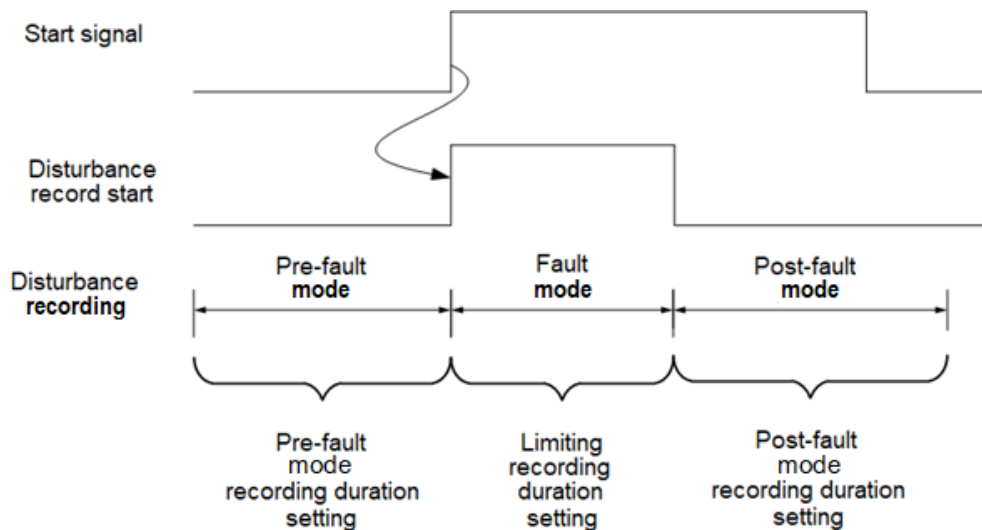

Figure 38 – Diagram of generating disturbance record in case of continuous start signal

Date and time of creation of disturbance record file correspond to the time of disturbance recorder start.

Information on time and reason of start is inside the disturbance record.

The values of the device at the time of disturbance recorder start are available for viewing when opening a file with the *.hdr extension in any program for viewing text files.

The name of the disturbance record data file in proprietary format is formed in the following way: CONFIGURATION_NAME.AXXXX,

where CONFIGURATION_NAME is the name of the device configuration file;

a – start of disturbance record file extension;

NNNN – serial number of start, when 9999 serial number is reached, the count starts again with 0000.

For example, a file with s0101.a0000 name is the very first disturbance record.

Disturbance recording is in the non-volatile ROM. The maximum memory volume for one disturbance record is 13 Mbyte. Simultaneously a disturbance record is saved in the memory card. Recording is carried out according to the "loop" principle: when the memory card is full, the oldest disturbance records are erased from it.

The assignment of disturbance recording is carried out by using the display and keypad of the device or via PC and EKRASMS-SP software. Disturbance reading is performed both from digital communication ports using the software package EKRASMS-SP, and using a flash drive through a USB port located on the front panel of the device.

There is an option of edge-triggered (transfer from "0" to "1") and fall-triggered (from "1" to "0") disturbance recording start of any of 1,024 logical signals, selected from any available protection, emergency control or logical function of the device.

Disturbance recorder can be enabled from any signal that is assigned by user.

The device has an option to select up to 64 analog and up to 1024 logical signals for simultaneous disturbance recording.

Start of emergency process recording mode is performed in case of starting pulse duration not less than 0.001 s.

The frequency of recorded parameters (disturbance recording frequency) is equal or is two times larger than the operating frequency – the frequency of cycle operation of the device function processor.

Disturbance recording frequency is set during configuration and can be equal to:

- 2,400 Hz or 1,200 Hz;
- 2,000 Hz or 1,000 Hz.

Duration of analog or binary information recording is determined by the time of emergency mode and by settings by record time of pre-fault and post-fault mode.

The minimum setting of pre-fault record duration is 0.1 s. The minimum setting of post-fault record duration is 0 s. Maximum settings are limited by the memory volume for disturbance records, the quantity of recorded parameters. Under any conditions, it possible to specify the settings of minimum 1 s and provide duration of a disturbance record of minimum 10 s.

Quantity of registered emergency processes is not less than 10. Maximum quantity is set in settings and depends on the memory card capacity. Total record duration is not less than 150 s at 22 analog and 128 binary recorded signals.

7.4 Synchronizing device date and time

The device has real time hours with an independent power source. To compensate error of internal clock rate, they must be synchronized from time to time (with the source of accurate time).

The options indicated in table 48 should be used to ensure time synchronization accuracy up to 1 ms.

Table 48 – Time synchronization options with an accuracy of 1 ms

Option No.	Protocol
1	PTPv2
2	IRIG-B007
3	SNTP + IRIG-B003
4	SNTP + PPS
5	IEC 60870-5-103 + IRIG-B003
6	IEC 60870-5-103 + PPS
7	IEC 60870-5-104 + IRIG-B003
8	IEC 60870-5-104 + PPS
9	Modbus TCP + IRIG-B003
10	Modbus TCP + PPS
11	Modbus RTU + IRIG-B003
12	Modbus RTU + PPS

The device supports the following types of hardware synchronization: PPS pulsed synchronization and IRIG-B synchronization. Hardware synchronization is used when timing accuracy is required to be less than 1 ms.

1) PPS pulsed synchronization

The algorithm of forming the device actual time when using PPS time synchronization is shown in figure 39.

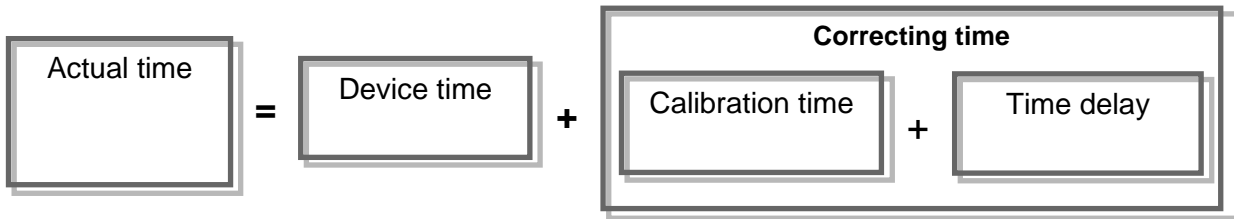

Figure 39 – Actual device time (PPS pulsed synchronization)

The device time is corrected by synchronization pulses (synchropulses), upon arrival of which the time is rounded to seconds. Start of synchronization is carried out by edge-triggered and fall-triggered synchropulse. The permissible deviation of synchropulse period is set by a setting. If a synchropulse does not meet requirements (synchropulse period, permissible deviation), warning failure is set, and hardware synchronization is not carried out. Calibration time considers time spent for passage of data by network from the source (for example, PCS system) to the receiver (the device). Time delay is designed for offset from interferences on the line. It is not an editable parameter, it has a default value of 15 ms.

Parameters of PPS pulsed synchronization:

- synchropulse time, s;
- Start of synchronization: edge-triggered and fall-triggered;
- calibration time, ms;
- permissible deviation, ms.

2) IRIG-B synchronization

At IRIG-B synchronization, the device actual time is renewed by a signal on IRIG-B input.

Hardware synchronization window provides:

- choosing a synchronization type: pulsed, IRIG-B;
- setting synchronization parameters;
- enabling/disabling device hardware synchronization.

Parameters of IRIG-B synchronization: standard modification (B003, B007).

Hardware synchronization operates only combined with software time synchronization (excluding IRIG-B007).

In case hardware synchronization is off and there is no software synchronization, device time synchronization is not performed.

8 Operation with the device from the front panel

Device menu structure is shown in figure 40.

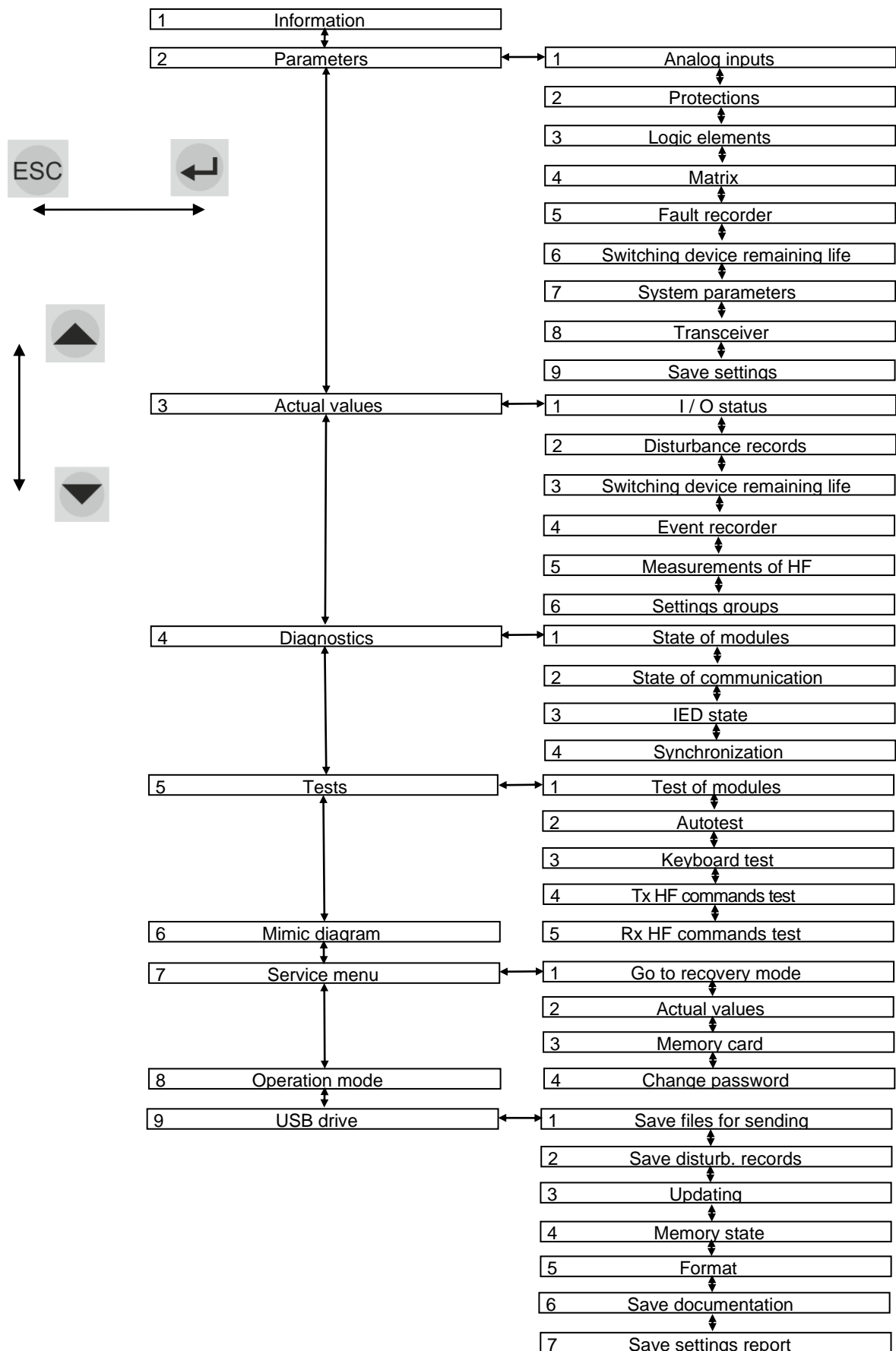

Figure 40 – Device menu structure

8.1 Navigating the device menu

The device menus can be navigated using the cursor up / down buttons and the keyboard on the front panel of the device.

For example, to go to the device menu item "**Actual values**" → "**I/O status**" → "**Analog signals**", one can use the successive pressing of the buttons "3 – 1 – 1" from the main menu window, or using the cursor up / down to select the corresponding menu item and by pressing the "↵" ("ENTER") button go to the next menu level. To go to the previous menu level, press the "Esc" button.

8.1.1 Viewing information on the device (**Information** main menu item)

8.1.1.1 **Information** menu provides viewing of general information on the device:

- design of the device;
- station name;
- name of protected facility;
- information on the device files;
- version of installed software.

Combination of "Fn + 7 + 9" buttons provides display of the information about the project files and device firmware files on the screen.

8.1.2 Editing of settings and parameters (**Parameters** main menu item)

To enter **Parameters** menu, access password is requested. Enter a combination of symbols, which is a password, and press "↵" ("ENTER") button. The user enters the menu, the device switches to the edit mode. Pressing "ESC" button enables entering the menu, but in the viewing mode.

The device settings and parameters can be changed within a certain range. **Parameters** menu is designed to view and change the device settings and parameters. If the number of parameters is greater than it can be displayed, the vertical scroll stripe appears to the right, and the "▲" and "▼" buttons are used for shifting.

Activation of this menu item does not switch off the device, it continues to operate in the same mode it operated before entering this menu item.

Parameters for editing are selected by shifting the cursor, and the selected parameter is highlighted by changing the background color.

When pressing the "↵" ("ENTER") button in the selected parameter, the device switches to the mode of changing parameters and there is "Edit" sign in the bottom of the screen.

To enter a new value, use digit buttons and decimal point ".". "Fn + ◀" button deletes incorrect symbols. Enter a value by pressing "↵" ("ENTER") button. After that, it is checked automatically whether the value can be set for the corresponding parameter. If the selected value is not acceptable, it is changed to its previous state. Escape the mode of parameter change with returning to the previous value by pressing "ESC" button. In the mode of parameter change by the

combination of “Fn + ▼” buttons, one can change the setting symbol to the opposite one if the range of parameters values allows.

All changes made in parameters and settings are temporarily saved in the device RAM and are lost when the device is turned off or restarted, or after time delay (the factory-set time of 60 s cannot be changed).

CAUTION

To apply the settings and save changes in the non-volatile memory, use the **Save settings** menu (see 8.1.2.10)!

The settings of the measuring elements and device parameters can be edited via service port (Ethernet) located on the front panel of the device by means of the software package EKRASMS-SP. If necessary, it is possible to record the settings for other ports located on the rear panel of the device.

8.1.2.1 Analog input parameters (**Parameters** → **Analog inputs** menu item)

Analog inputs menu (see figure 41) provides editing the parameters of each input analog signal of the device: nominal value, ratio of primary values.

Ratio of primary values (transformation ratio) shows how many times the external measuring current and voltage transformer reduces rated value in comparison with the value received by the device analog input module.

After selecting analog input and pressing the “↵” (“ENTER”) button, a window with edited parameters appears on the screen.

To enter any parameter, follow the instructions of 8.1.2.

```

\Analog inputs
N Name Nominal Trans.ratio
1 Ug, YA 57.740 105
2 XXXXXXXXXXXXXXXXXXXX 000.000 000
3 XXXXXXXXXXXXXXXXXXXX 000.000 000
4 XXXXXXXXXXXXXXXXXXXX 000.000 000
5 XXXXXXXXXXXXXXXXXXXX 000.000 000
6 XXXXXXXXXXXXXXXXXXXX 000.000 000
7 XXXXXXXXXXXXXXXXXXXX 000.000 000
8 XXXXXXXXXXXXXXXXXXXX 000.000 000
9 XXXXXXXXXXXXXXXXXXXX 000.000 000
10 XXXXXXXXXXXXXXXXXXXX 000.000 000
11 XXXXXXXXXXXXXXXXXXXX 000.000 000
Active group: Settings group 1
13.02.2022 16:02:57
```

Figure 41 – General view of **Analog inputs** menu

8.1.2.2 Protections parameters (**Parameters** → **Protections**)

This menu item (see figure 42) is intended to edit protections settings, and to enable and disable protections. Names of menu items depend on functions performed by the device.

To enter any parameter, follow the instructions of 8.1.2.

There are several combinations of buttons for operating with parameters, their description is presented in table 49.

Table 49 – Button combinations for operating in the "Protections" menu

Button combination	Value
Fn + 2	Selection of settings group
Fn + 3	Primary value
Fn + 4	Secondary value
Fn + 5	Relative value
Fn + left	Moving for 5 protections forward
Fn + right	Moving for 5 protections back
Fn + up	Page up
Fn + down	Page down
Fn + up, Fn + down	Change of sign (for parameters of protections settings)
Leftward	Moving to next protections
Rightward	Moving to the previous protections

To enable/disable protections: "↵" ("ENTER") button by cyclic principle.

To switch to next/previous protections: "▶" / "◀" buttons.

```

\Protections
N:1 Name: I1>
  Enable-disable:Enabled
  Settings:
  Oper.           1.050  A
  Kres.           0.95
  Group: Settings group 1 (active)
  13.02.2022 16:02:57
  
```

Figure 42 – General view of Protections menu item

8.1.2.3 Logic elements (**Parameters** → **Logic elements** menu item)

This menu (see figure 43) allows you to edit:

- time delays;
- program switches;
- counters;
- pulse generator;
- counter of OLTC (On-Load Tap Changer) stages;
- pulse formers.

To enter any parameter, follow the instructions of 8.1.2.

If several groups of settings are used in the device, then switching between groups of settings: a combination of buttons "Fn + 2".

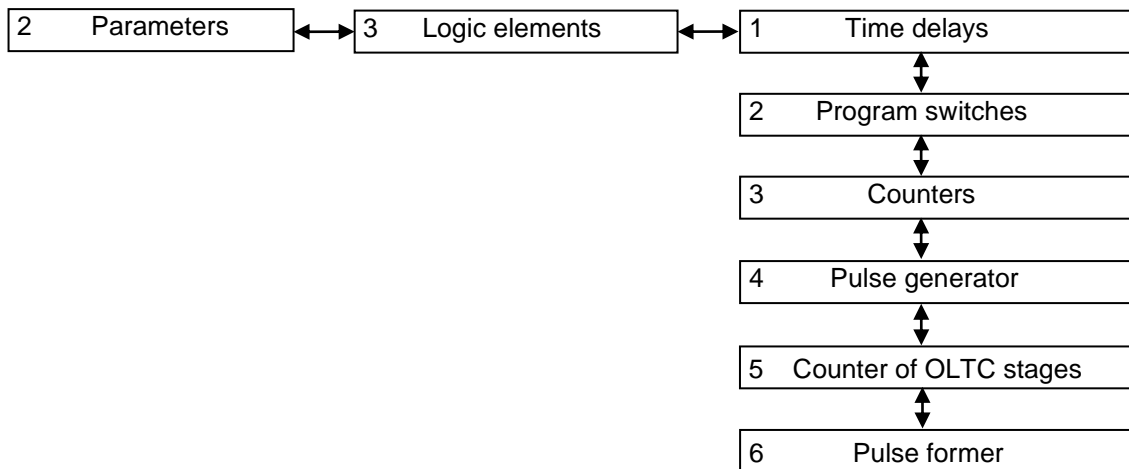

Figure 43 – **Logic elements** menu structure

Basic logic elements, applicable to configure the device, their principle of operation and purpose are given in the document "EKRASMS-SP software package", annex A.

8.1.2.3.1 Time delays

The menu includes list of time delays (DT) in current configuration and value in seconds. User can edit time delay values. Time delay name corresponds to the functional diagram. All time delays are assigned in the configuration as unchangeable and changeable. Unchangeable time delays cannot be edited via the display of the device and can be viewed only.

8.1.2.3.2 Program switches

The menu includes the list of program switches (VXN) in the current configuration. User can edit the switch status. As well as for time delays, they can be assigned in the configuration as unchangeable or changeable. When pressing "↵" ("ENTER") on the selected switch, its status switches from "ENABLED" to "DISABLED" and vice versa.

8.1.2.3.3 Counters

The menu includes the list of counters (DC) in the current configuration. The user can edit the values of the counter settings. As well as for time delays, they can be assigned in the configuration as unchangeable or changeable.

The format of counter values is an integer.

8.1.2.3.4 Pulse generator

The menu includes the list of square-wave generators (Gen) in the current configuration. User can edit settings: signal period and pulse duration (in seconds). As well as for time delays, they can be assigned in the configuration as unchangeable or changeable.

8.1.2.3.5 Counter of OLTC stages

The menu provides editing of the following parameters:

- min. stage – minimum tap changer position stage;

- max. stage – maximum tap changer position stage;
- init. stage – initial tap changer position stage;
- list – list of “dead” tap changer position stages. The settings are given as integer values.

If there are several of them, then they must be listed separated by commas.

Additionally, the following items are displayed:

- counter – name of current tap changer position component;
- q-ty – quantity of “dead” tap changer position stages.

The combination of “Fn + ◀” and “Fn + ▶” buttons enables to select an tap changer position module. As well as for time delays, these settings can be assigned in the configuration as unchanged or changeable.

8.1.2.3.6 Pulse former

The menu includes the list of pulse formers (TMOC, TMOI) in the current configuration. User can edit time delays of pulse formers (in seconds). As well as for time delays, these settings can be assigned in the configuration as unchanged or changeable.

8.1.2.4 Matrix (menu item **Parameters** → **Matrix**)

This menu (see figure 44) provides an option for each logic signal to assign indication and disabling outputs and has the following items:

- indication matrix;
- matrix of binary outputs;
- logic signals.

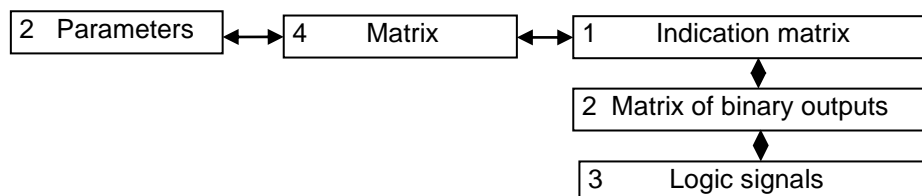

Figure 44 – **Matrix** menu structure

The combination of “Fn + ◀” and “Fn + ▶” buttons enables to select a needed module of output relays or the required column of LEDs. “◀” and “▶”, “▲” and “▼” buttons are used to shift along the matrix.

Signal is assigned/released by pressing the “↵” (“ENTER”) button in the proper matrix cubicle.

Indication matrix

This menu (see figure 45) provides possibility for each logic signal (vertical column on the left) to set impacts on indication outputs (upper horizontal line) in correspondence with the signaling matrix of protections set functional diagram. If one output corresponds to several signals, impact signal is calculated by “OR” scheme.

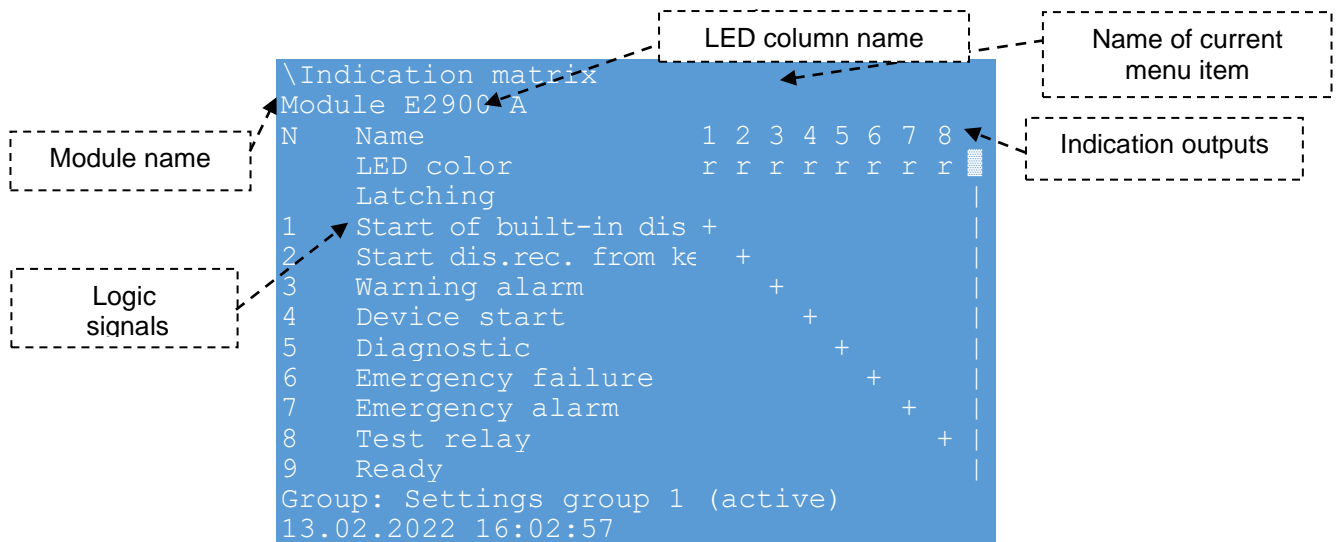

Figure 45 – General view of **Indication matrix** menu

The indication matrix allows to change the color of the LED (green / red), select the LED operation mode – with latching when actuated or without latching. Switching between the indication modules (A, B, C ...) is carried out using the "Fn + ◀" and "Fn + ▶" buttons. For faster scrolling through the list of logical signals, you can use the combination of "Fn + ▼" and "Fn + ▲" buttons.

Matrix of binary outputs

This menu (see figure 46) provides possibility for each logic signal (vertical column on the left) to set impacts on disabling outputs (upper horizontal line) in correspondence with the matrix of binary outputs. If one output corresponds to several signals, impact signal is calculated by "OR" scheme.

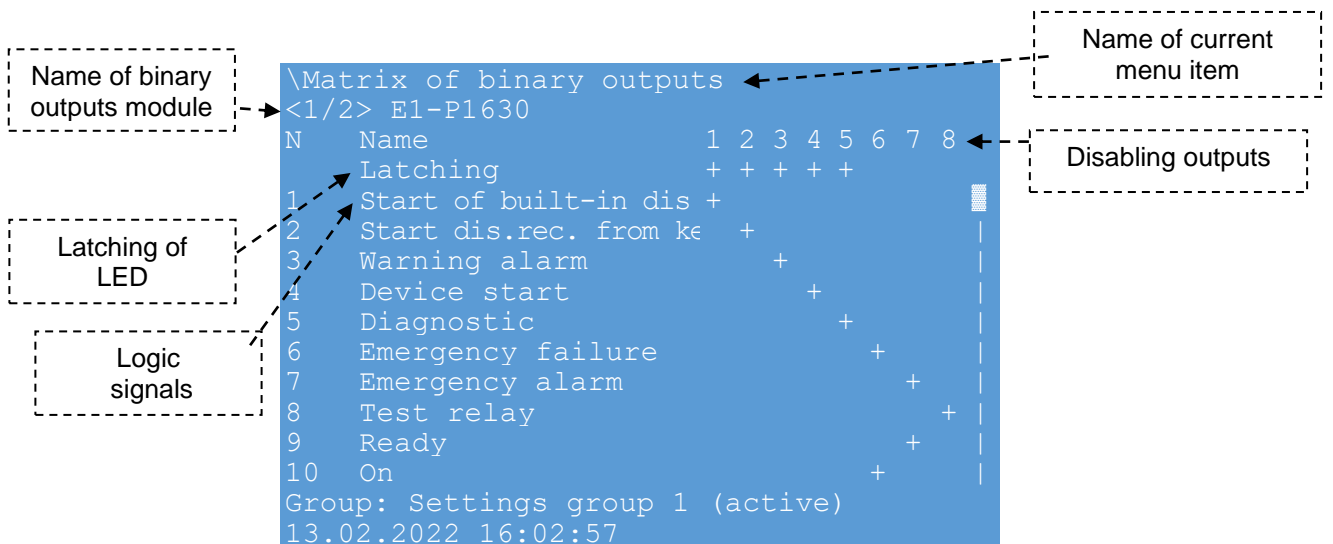

Figure 46 – General view of **Matrix of binary outputs** menu

User can latching the operation of the output relay when it is activated. After latching the output relay, its reset will be carried out only by the user using the front panel of the device

("Fn + 0" buttons), using the special binary input "Reset" on the power supply module of the device, or using the application software.

Switching between blocks of output circuits is carried out using the "Fn + ◀" and "Fn + ▶" buttons. For faster scrolling through the list of logic signals, you can use the combination of "Fn + ▼" and "Fn + ▲" buttons.

Logic signals

This menu (see figure 47) provides an option to edit a signal list for transmission to PCS. Also the menu contains two types of signals: warning and emergency.

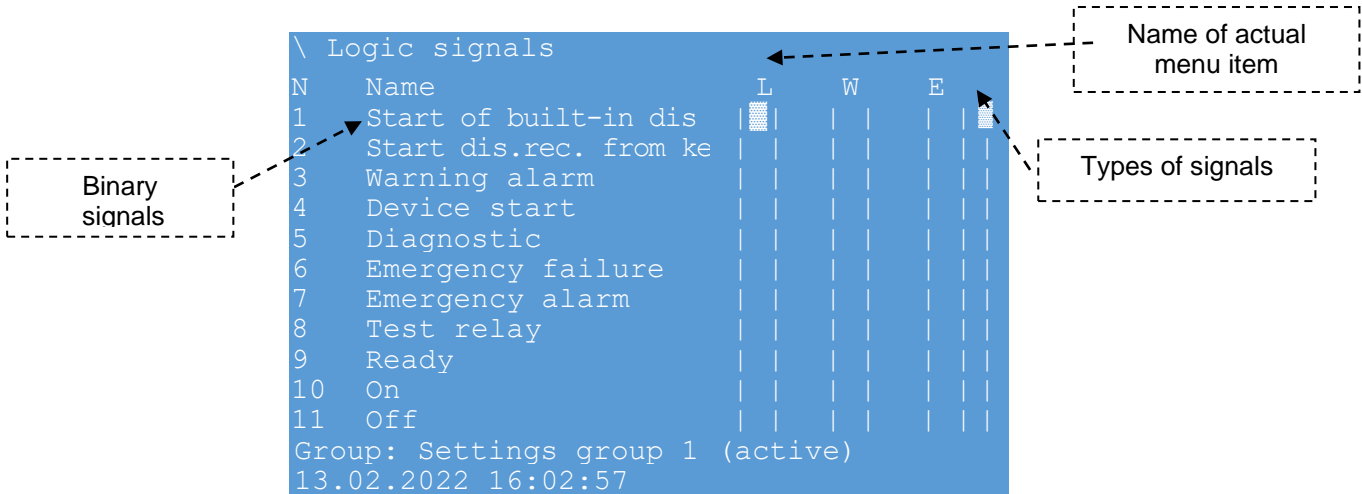

Figure 47 – General view of **Logic signals** menu

Column designation:

- "L" - the signal is latching in the PCS;
- "W" - the signal acts in the warning alarm of the PCS;
- "E" - the signal acts in the emergency alarm of the PCS.

8.1.2.5 Disturbance recording function (menu item **Parameters** → **Fault recorder** → **Disturbance recorder**)

Time settings and disturbance recording parameters of the device are set in the **Disturbance recorder** menu, which contains a submenu (see figure 48):

- analog signals;
- logic signals;
- calculated values;
- disturbance recording time.

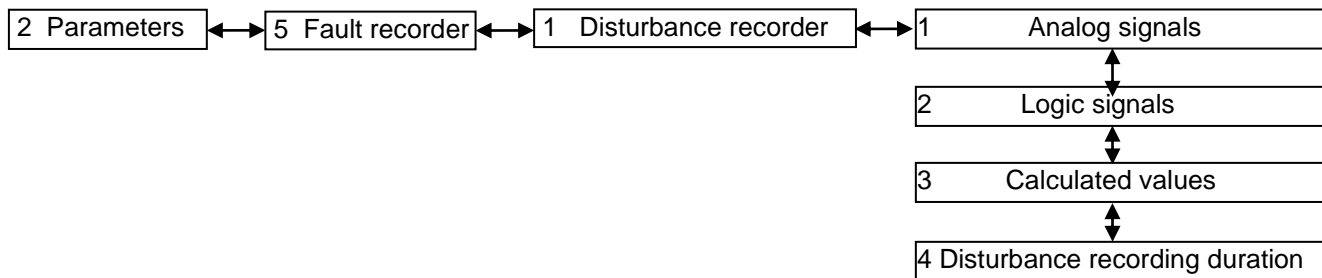

Figure 48 – **Disturbance recorder** menu structure

8.1.2.5.1 **Analog signals** menu (figure 49) includes the list of input analog signals, recorded to the disturbance record. The [] (absent) value corresponds to the switched off condition, and [+] value corresponds to the switched-on state of the disturbance recording mask. The number of recorded signals can be from zero up to the number of all available (real and software-calculated circuits) analog inputs of the device.

```

\Analog signals
N   Name                               Dist
1   Ict1 A                             +
2   Ict1 B                             +
3   Ict1 C                             +
4   Ict2 A                             +
5   Ict2 B                             +
6   Ict2 C                             +
7   Uvt1 A                             +
8   Uvt1 B                             +
9   Uvt1 C                             +
10  Uvt2 A
11  Uvt2 B
12  Uvt2 C
13.02.2022 16:02:57

```

Figure 49 – General view of **Analog signals** menu

8.1.2.5.2 **Logic signals** menu (figure 50) contains the list of logic signals recorded in a disturbance record. The [] (absent) value in the Dist column corresponds to the switched off condition, and [+] value corresponds to the switched-on state of the disturbance recording mask.

```

\Logic signals
N   Name                               Dist  ETS  FTS
1   Start of built-in dis               |+|   | | |
2   Start dis.rec. from ke              |+|   |+| |
3   Warning alarm                       |+|   | | |
4   Device start                        |+|   | | |
5   Diagnostic                          |+|   | | |
6   Emergency failure                   |+|   | | |
7   Emergency alarm                     |+|   | | |
8   Test relay                          |+|   | | |
9   Ready                               |+|   | | |
10  On                                  |+|   | | |
11  Off                                  |+|   | | |
13.02.2022 16:02:57

```

Figure 50 – General view of **Logic signals** menu

It is provided with an option to set up both an edge-triggered and fall-triggered disturbance recording of the logic signal. ETS – Edge-triggered start. FTS – Fall-triggered start.

Edge-triggered and fall-triggered action of the logic signal causes disturbance recorder start, is permitted by setting a parameter in **Start** column of the signal to the switched-on position, and it is inhibited by setting to the switched off position. Initiation of disturbance recorder start can be set for all logic signals in the device.

The parameter is set/reset by the “↵” (“ENTER”) button.

8.1.2.5.3 **Calculated values** menu (figure 51) includes the list of calculated values, recorded to the disturbance record. The [] (absent) value in the Dist column corresponds to the switched off condition, and [+] value corresponds to the switched-on state of the disturbance recording mask.

```
\Calculated values
N   Name           Dist
1   Icr1 I2        +
2   Uvr1 U2        +

13.02.2022 16:02:57
```

Figure 51 – General view of **Calculated values** menu

8.1.2.5.4 **Disturbance recording duration** menu item (see figure 52) provides setting up the following disturbance recording parameters:

- pre-fault time, s – pre-fault record time in seconds;
- max. fault time, s – fault recording duration limit setting in seconds;
- post-fault time, s – post-fault record time in seconds;
- q-ty of disturbance rec. – permissible number of disturbance records (should not exceed the maximum quantity of disturbance records).



CAUTION

If the new “Quantity of disturbance records” setting value is less than the actual value, then after application, disturbance records with the number greater than the new quantity of disturbance records, are deleted, so the quantity of disturbance records corresponds to the new setting value!

It also provides viewing the following parameters:

- max. dist.rec. duration, s – maximum duration of disturbance recording in seconds, it is determined depending on the quantity of signals, assigned for disturbance recording (with no account for free space in the memory card);
- max. q-ty of dist. rec. – maximum quantity of disturbance records, calculated depending on free space in the memory card and set disturbance recording duration settings.

To enter any parameter, follow the instructions of section 8.1.2.

```

\Disturbance recording duration
Parameter                               Value
Pre-fault time, s                       1.000
Max. fault time, s                      5.000
Post-fault time, s                      1.000
Q-ty of dist. rec.                       30
Max. dist.rec. duration, s              10560.000
Max. q-ty of dist. rec.                 1731

Active group: Settings group 1
13.02.2022 16:02:57

```

Figure 52 – General view of **Disturbance recording duration** menu

8.1.2.6 Event recorder (menu **Parameters** → **Fault recorder** → **Event recorder**)

The event recorder in the device is designed for recording of changes of all logical signals with latching the event date and time. The device has two types of recorded events. The first type includes the internal events in the device, all other events refer to the second type. The internal events of the device are formed in the following cases:

- when the device is switched on and switched off;
- when the device is restarted in case the self-diagnostic system finds any fault;
- when settings change;
- in case of any malfunction.

The events are recorded into non-volatile memory that saves information with the device de-energized. Each change of recorded signals obtains a time stamp with a resolution of 0.001 s. The event recorder has a capacity of 7,500 time stamps. When the memory is full, new events are recorded instead of the oldest events.

Event recorder menu contains submenu which enable to control recording of logic signals: to include and exclude them from the list of recorded signals (see figure 53):

- logic signals;
- binary inputs;
- binary outputs;
- calculated values.

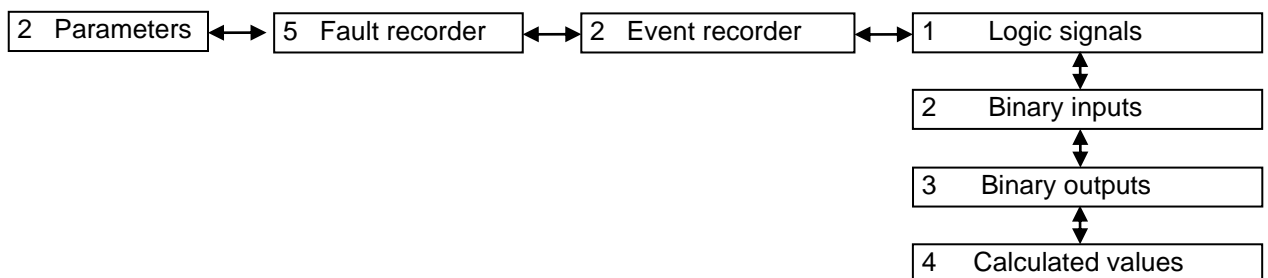

Figure 53 – **Event recorder** menu structure

All logic signals have an option to be included and excluded from the list of recorded signals (the “↵” (“ENTER”) button). The change of a logical signal excluded from the list of recorded signals does not form any events. The list of device internal recorded events cannot be controlled.

The event recorder cannot record all logic signals simultaneously.

8.1.2.7 Switching device remaining life (menu item **Parameters** → **Switching device remaining life**)

Calculation of mechanical and remaining life (circuit breakers, disconnectors, etc.) is designed to control the state of switching device during the current operation period.

Switching device remaining life menu sets circuit breaker settings (see figure 54):

Enabled life calculation – “+” value corresponds to activated state of circuit breaker life calculation, otherwise, circuit breaker life calculation is not carried out.

Switching device characteristics:

Table of permissible closings – quantity of permissible closings N_{CLOS} at set closing current I_{CLOS} , kA. Quantity of points is maximum 20.

Table of permissible openings – quantity of permissible openings N_{TRIP} at set opening current I_{TRIP} , kA. Quantity of points is maximum 20.

Operation by residual life – operation stages by residual life for three phases in percents. Number of operation stages is four.

Table of initial closings – quantity of initial closings of each phase $N_{ph.A}$, $N_{ph.B}$, $N_{ph.C}$ at set current I_{CLOS} , kA.

Table of initial openings – quantity of initial openings of each phase $N_{ph.A}$, $N_{ph.B}$, $N_{ph.C}$ at set current I_{TRIP} , kA.

As the number of commutating device settings is greater than it can be displayed, the vertical scroll stripe is located to the right, and “▲” and “▼” are used for shifting.

```

\Switching device remaining life
Switching device: <1/9> SHR2-500 VL1
Enable calc.=[ ]
Permissible closing:
N I close,A      N close
1 000.000        00000
2 000.000        00000
Permissible openings:
N I trip,A       N trip
1 000.000        00000
2 000.000        00000
Operation by residual life, %:
N ph.A          ph.B          ph.C
Active group: Settings group 1
13.02.2022 16:02:57
    
```

Figure 54 – General view of **Switching device remaining life** menu

Shifting among the cells – “◀”, “▶” and “▼”, “▲” buttons. Cell selection – “↵” (“ENTER”).
Commutating device selection: combination of buttons “Fn + ◀”, “Fn + ▶”. To enter any parameter, follow the instructions of 8.1.2.

8.1.2.8 System parameters (menu item **Parameters** → **System parameters**)

The device system parameters are adjusted by the **System parameters** menu, which includes (see figure 55):

- communication parameters;
- module parameters;
- calculated values;
- display settings;
- time synchronization;
- system time;
- limit values.

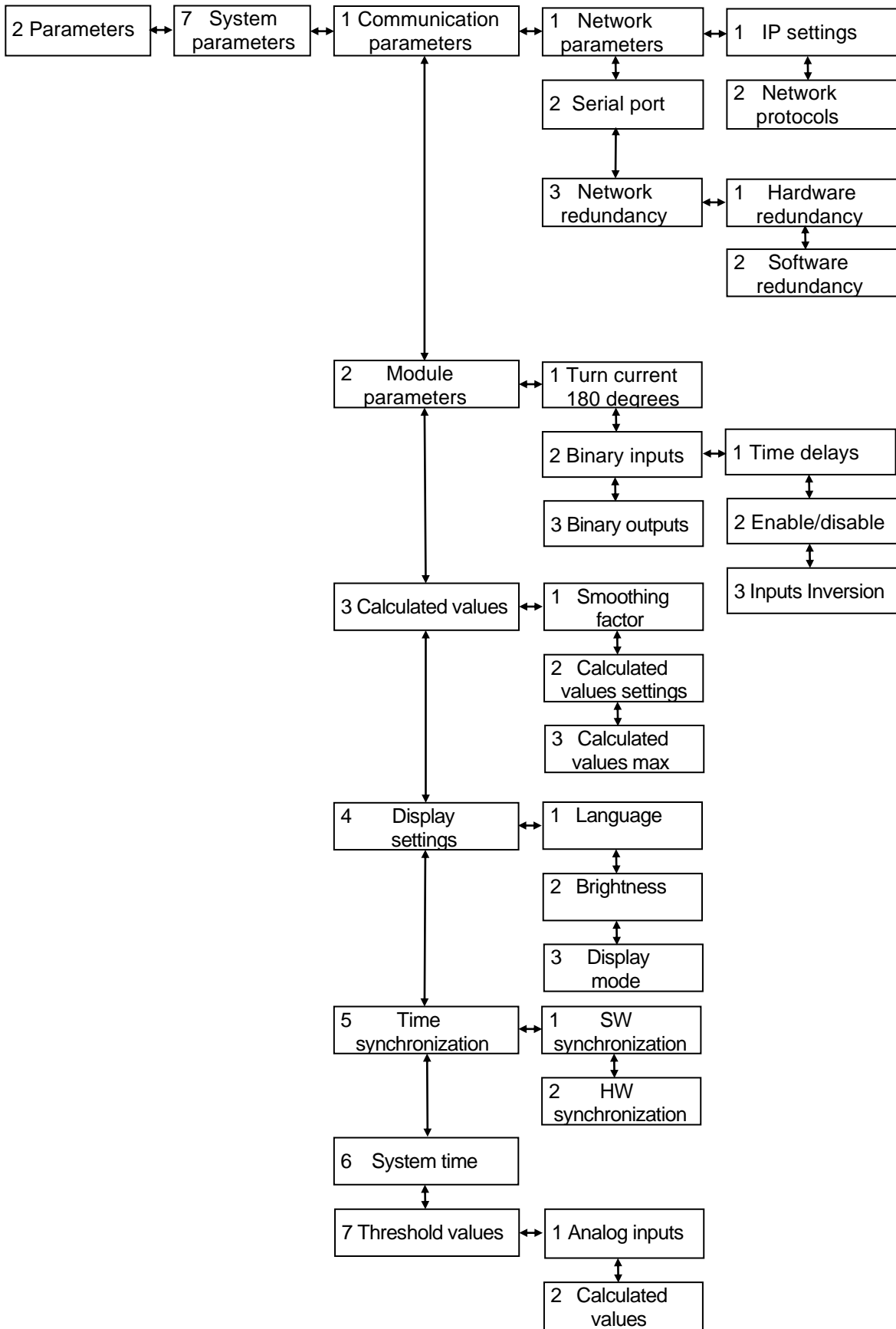

Figure 55 – **System parameters** menu structure

8.1.2.8.1 Communication parameters (menu item **Parameters** → **System parameters** → **Communication parameters**)

Communication parameters menu contains:

- network parameters;
- serial ports;
- network redundancy.

To enter any parameter, follow the instructions of section 8.1.2.

Network parameters

This menu (see figure 55) provides editing general parameters of the device communication, and also parameters of network protocols, and contains the following submenus:

- IP settings.
- network protocols.

Ethernet software protocols: Modbus TCP/IP, SNTP, IEC 60870-5-104, IEC 61850-8-1.

IP settings menu (see figure 56) provides setting IP address, mask and gateway for main and service network port.

Service network port is designed for maintenance, adjustment and configuration of the IED.

```
\IP settings
Ethernet 1
IP-address=192.168.003.001
Mask=255.255.255.000
Gateway=192.168.003.237
Ethernet 0 (Service port)
IP-address=172.016.064.001
Mask=255.255.000.000
Gateway=192.168.003.237

Active group: Settings group 1
13.02.2022 16:02:57
```

Figure 56 – General view of **IP settings** menu

Network protocols menu provides editing communication and time synchronization protocol parameters: SNTP, PTP, IEC 60870-5-104, IEC 61850-8-1 and ModbusTCP Server. The selection of the communication and time synchronization is carried out using the "Fn + ◀", "Fn + ▶" buttons.

General settings of SNTP protocol:

- server IP address;
- server port (by default 123);
- server synchronization period (by default 64 s);
- response wait time;
- protocol build tag;
- time server feature;

- priority of time server selection as main synchronization source.

The value [] (absent) corresponds to the disabled state, and the value [+] corresponds to the enabled state.

General settings of PTP protocol:

- server synchronization period (by default 60 s);
- protocol build tag.

The value [] (absent) corresponds to the disabled state, and the value [+] corresponds to the enabled state.

General settings for the Modbus/TCP Server protocol:

- protocol build tag.

The value [] (absent) corresponds to the disabled state, and the value [+] corresponds to the enabled state.

General settings of protocol under IEC 60870-5-104:

- quantity of clients;
- transmission type of analog measurements;
- data type of analog measurements;
- transmission period of analog measurements;
- binary groups – set of transmitted binary signals;
- analog groups – set of transmitted analog measurements;
- protocol build tag.

The value [] (absent) corresponds to the disabled state, and the value [+] corresponds to the enabled state.

General settings of protocol under IEC 61850-8-1 (2004):

- protocol build tag.

The value [] (absent) corresponds to the disabled state, and the value [+] corresponds to the enabled state.

Serial ports

This menu (see figure 57) provides editing serial port parameters (general settings, protocol parameters): "RS-485-1", "RS-485-2". The selection of the serial communication port for displaying information on it on the screen is carried out using the "◀" and "▶" buttons.

```

\Serial ports
Interface=RS-485-1
Protocol = Modbus RTU Server
Port speed      = 115200
Data bits      = 8
Parity         = Even
Stop bits      = 1
Delay in symbols = 0
IED network address = 1

Active group: Settings group 1
13.02.2022 16:02:57

```

Figure 57 – General view of **Serial ports** menu

Parameters of communication settings are provided in table 50.

Table 50 – General protocol settings

Parameter	Description
Port speed	Operation rate of serial communication port RS-485-1 RS-485-2. It can take values from the following series: 9,600; 14,400; 19,200; 38,400; 56,000; 57,600; 115,200 bauds and set in accordance with the technical means used when organizing communication channels
Data bits	It can take values either "5", or "6", or "7" or "8"
Parity	It can take values: – "None"; – "Odd"; – "Even"; – "Marker"; – "Space"
Stop bits	The quantity of stop bits. It can take values from 1 to 2
Delay in symbols	Integer number of points from 0 to 1,000
IED network address	IED network address is a unique value for all devices in one network and it is designed for single-value determination of the device. The device network address for communication can vary from 1 to 247

RS-485 software protocols: Modbus/RTU, IEC 60870-5-103 and IEC103Master. Assignment of two or more data exchange protocols per one communication interface is not allowed.

Network redundancy

This menu provides configuring Ethernet redundancy and contains the following submenus:

- hardware redundancy;
- software redundancy.

The **Hardware redundancy** menu provides configuring Ethernet redundancy when a network redundancy card is available (a sign of a network redundancy card in the device is two adjacent Ethernet connectors labeled Ethernet 1.1 and Ethernet 1.2, otherwise there is no redundancy card). The following Ethernet redundancy protocols are available for configuration: Link backup, PRP.

The description of common parameters for all redundancy protocols is given in table 51.

Table 51 – The description of common parameters for all redundancy protocols

Parameter	Description
IP address	IP address of redundancy module
File mask	Subnet mask of redundancy module
Gateway	Subnet gateway of redundancy module
VLAN control	Virtual network, which provides access to redundancy module settings. It affects all protocols of remote access to redundancy module. To maintain proper VLAN operation when setting a value different from 0, it will be written in VLAN table on the external module ports

Note – If the network does not support PRP protocols, these modes must be off, otherwise, problems with communication can occur.

Description of redundancy adjustment under protocol PRP is shown in table 52.

Table 52 – Description of redundancy adjustment under protocol PRP

Parameter	Description
Reception of supervision packets	Enable Supervision Packet monitoring. Reception of packets is required for statistics acquisition and PRP network diagnostic
Transmission of control packets	Enable Supervision Packet creation from this redundancy module. Transmission of packets is required for statistics acquisition and PRP network diagnostic
Transmission of VDAN packets	Enable transmission of supervision VDAN packets These packets contain additional diagnostic information on network devices connected to PRP network via the device redundancy module. Supervision VDAN packets are transmitted only if Transmission of supervision packets parameter is on

The **Software redundancy** menu provides configuring network redundancy at the software level if there are several Ethernet interfaces not used by the network redundancy card. The following redundancy protocols are available for configuration: Link backup and PRP.

Link backup data is shown in table 53.

Table 53 – Link backup data

Name	Description
LAN 1	Name of the first network interface
LAN 2	Name of the second network interface
Use PING=[]	Enabled (1) or Disabled (0) ping check mode
PING IP=	IP address for ping
Timeout	Time-out

PRP redundancy data are shown in table 54.

Table 54 – PRP redundancy data

Name	Description
LAN A	Name of the first network interface
LAN B	Name of the second network interface

8.1.2.8.2 Module parameters (menu item **Parameters** → **System parameters** → **Module parameters**)

This menu provides editing parameters of analog inputs, binary inputs and outputs. To enter any parameter, follow the instructions of 8.1.2. Selection of the following/previous module: combination of “Fn + ►” / “Fn + ◀” buttons.

Turn current 180 degrees

This menu item (figure 58) allows you to turn the current 180 degrees. This operation is possible for all analog current inputs.

```

\Turn current 180 degrees
<1/1> D3157
N Sensor      Circuit      Turn current
1 ~I1 (A)     I Y A;      [ ]
2 ~I2 (A)     I Y B;      [ ]
3 ~I3 (A)     I Y C;      [ ]
4 ~I4 (A)     1I Y A;     [ ]
5 ~I5 (A)     1I Y B;     [ ]
6 ~I6 (A)     1I Y C;     [ ]
7 ~I7 (A)     I zsct b-e  [ ]

13.02.2022 16:02:57
    
```

Figure 58 – General view of **Analog inputs** menu

Binary inputs

This menu contains (see figure 59):

- time delays;
- enable/disable;
- inputs inversion.

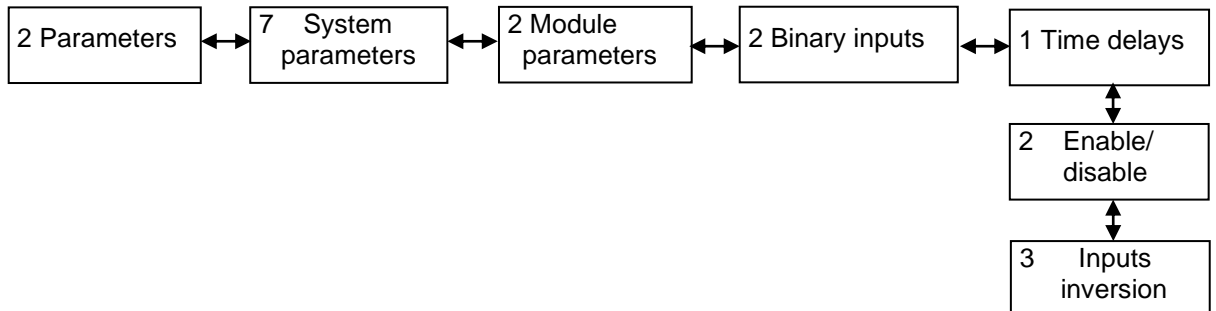

Figure 59 – Structure of **Binary inputs** menu

Time delays menu (see figure 60) is displayed in the form of a table. The user has an option to edit time delays for operation and reset of all binary inputs.

Time delays are set within the range from 0 to 9,999 ms. Default time delay value for operation is 15 ms, for reset is 6 ms.

```

\Time delays
<1/4> A-E9 EI2582
N Signal name Oper Res
1 IN6.1 15 6
2 IN6.2 15 6
3 IN6.3 15 6
4 IN6.4 15 6
5 IN6.5 15 6
6 IN6.6 15 6
7 IN6.7 15 6
8 IN6.8 15 6
9 IN6.9 15 6
10 IN6.10 15 6
Active group: Settings group 1
13.02.2022 16:02:57

```

Figure 60 – General view of **Time delays** menu

The **Enable Disable** menu (see figure 61) is displayed in the form of a table with columns "En/Dis" and "Value". The "En/Dis" setting with the [+] value indicates that the binary input is in the enabled state and the signal state depends on the level of the applied voltage to its input. The "En/Dis" setting with the value [] indicates that the binary input is in the disabled state and the state of the signal at its output depends on the value set in the "Value" field. Value [1] indicates that the output of the binary input will be a logic 1 signal, and value [0] – a logic 0 signal.

```

\Enable/Disable
<1/8> EI2582
N Name En/Dis Val.
1 IN6.1 [+] [0]
2 IN6.2 [+] [0]
3 IN6.3 [+] [0]
4 IN6.4 [+] [0]
5 IN6.5 [+] [0]
6 IN6.6 [+] [0]
7 IN6.7 [+] [0]
8 IN6.8 [+] [0]
9 IN6.9 [+] [0]
10 IN6.10 [+] [0]
Active group: Settings group 1
13.02.2022 16:02:57

```

Figure 61 – General view of **Enable/Disable** menu

Inputs inversion menu (see figure 62) is displayed in the form of a table. An "Enabled" setting indicates that the receive circuit invert capability is enabled and **does not indicate** that the receive circuit is enabled. Signal inversion can only be performed if the option to invert the signal has been enabled with the appropriate "Enabled" setting. If there is no appropriate permission, then it will not work to invert the receiving circuit.

```

\Inputs inversion
<1/9> EI2582
N Name Inv. Enabled
1 IN6.1 [ ] [+]
2 IN6.2 [ ] [+]
3 IN6.3 [ ] [+]
4 IN6.4 [ ] [+]
5 IN6.5 [ ] [+]
6 IN6.6 [ ] [+]
7 IN6.7 [ ] [+]
8 IN6.8 [ ] [+]
9 IN6.9 [ ] [+]
10 IN6.10 [ ] [+]
Active group: Settings group 1
13.02.2022 16:02:57

```

Figure 62 – General view of **Inputs inversion** menu

Binary outputs (see figure 63).

The user has an option to edit time delays for reset of all binary outputs. Time delays are set within the range from 0 to 9,999 ms in 1 ms steps, the default value is 0 ms.

```

\Binary outputs
<1/6>: A-E3 P1630
N Signal name Res
1 Open oper. power infeed Q 0
2 Open backup power infeed Q 0
3 Open oper. power infeed Q 0
4 Open oper. power infeed Q 0
5 Open backup power infeed Q 0
6 Open backup power infeed Q 0
7 Open backup power infeed Q 0
8 Open backup power infeed Q 0
9 Open backup power infeed Q 0
10 Open backup power infeed Q 0
Active group: Settings group 1
13.02.2022 16:02:57

```

Figure 63 – General view of **Binary outputs** menu

8.1.2.8.3 Calculated values (menu item **Parameters** → **System parameters** → **Calculated values**)

This menu contains:

- smoothing factor;
- settings of calculated values;
- maximum calculated values.

Smoothing factor

Smoothing factors are used to calculate calculated values (calculated analog values during the device operation) for smoothing changes of the calculated value (pointer indicator simulation). Factor value is set within the range from 0.01 to 1.00.

X value with account for smoothing factor is calculated by the formula

$$X = X_{PREV} + k \cdot \Delta X, \tag{1}$$

where X_{PREV} – previous value;

k – smoothing factor;

ΔX – increment, calculated as a difference between the actual value and the previous value:

$$\Delta X = X_{ACT} - X_{PREV}. \quad (2)$$

Value of 0.1 means that the actual value will change by 10 % from the difference between the new and the previous value.

Value of 0 is an invalid value, no smoothing.

The smoothing factor is set for each calculated value.

Calculated values settings

Calculated values settings menu provides viewing settings parameters of calculated values on the device screen (see figure 64).

Switching between groups of settings: combination of "Fn + 2" buttons.

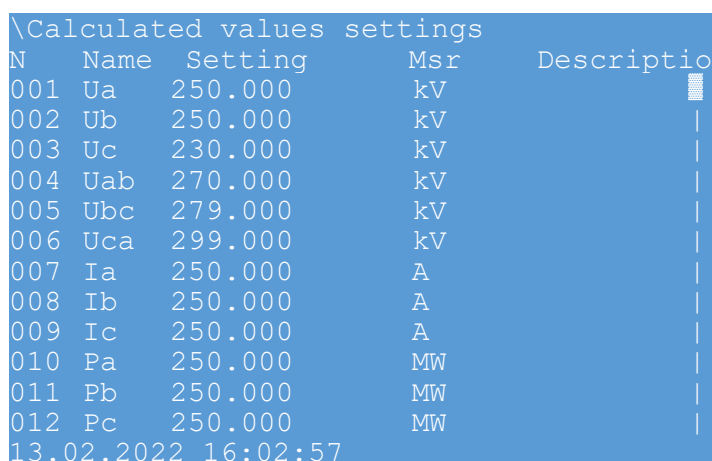

N	Name	Setting	Msr	Descriptio
001	Ua	250.000	kV	
002	Ub	250.000	kV	
003	Uc	230.000	kV	
004	Uab	270.000	kV	
005	Ubc	279.000	kV	
006	Uca	299.000	kV	
007	Ia	250.000	A	
008	Ib	250.000	A	
009	Ic	250.000	A	
010	Pa	250.000	MW	
011	Pb	250.000	MW	
012	Pc	250.000	MW	

13.02.2022 16:02:57

Figure 64 – General view of **Calculated values settings** menu

Calculated values max

Calculated values max menu provides editing the maximum value of the calculated value (see figure 65). Relatively to this value, the value of the dead zone is calculated. The dead zone determines by what value the signal must change in order for its updated value to be transmitted over digital communication protocols.

Editing of the maximum calculated values is carried out using the "↵" ("ENTER") button, moving through the list of calculated values using the "▲", "▼" buttons, fast moving through the list – "Fn + ▼", "Fn + ▲", deleting incorrectly typed characters – "Fn + ◀".

```

\Calculated values max
N   Name                               Setting
1   CM1                                100000
2   voltage                             6000
3   Bypass disconnecter
4   Earthing switch bypas
5   Bus disconnector1-22  11
6   Bus disconnector1-22  11
7   CB earthing switch bus12
8   CB earthing switch bus12
9   Bus disconnector2-2   13
10  Bus disconnector2-2   12
11  CB-220 AT3 resource   96
Active group: Settings group 1
13.02.2022 16:02:57

```

Figure 65 – General view of **Calculated values max** menu

8.1.2.8.4 Display settings (menu item **Parameters** → **System parameters** → **Display settings**)

This menu contains (see figure 66):

- Language;
- Brightness;
- Display mode.

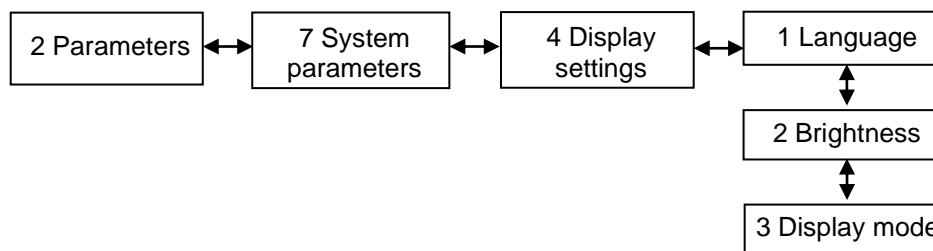

Figure 66 – Structure of **Display settings** menu

Language

In this menu item, the user can select the language in which all text will be displayed on the device display. Two languages are available by default: Russian and English.

Brightness

This menu provides adjustment of lighting and brightness of the LEDs, located on the device front panel.

Shifting in parameters – "▲" and "▼" buttons, parameter change – "▶" and "◀".

Save changes – [Save], selection confirmation – "↵" ("ENTER") button.

Display mode

In this menu item, the user can choose the values in which analog values will be displayed on the terminal display. Primary or secondary values are available for selection.

8.1.2.8.5 Time synchronization (menu item **Parameters** → **System parameters** → **Time synchronization**)

This menu provides editing parameters of software and hardware synchronization (see figure 67). To enter any parameter, follow the instructions in section 8.1.2. Time synchronization type selection: button "↵" ("ENTER").

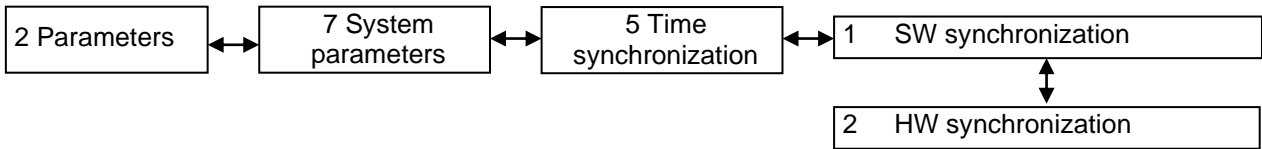

Figure 67 – Structure of **Time synchronization** menu

Software synchronization

Protocols of software time synchronization: SNTP, Modbus TCP/IP, Modbus/RTU, IEC 60870-5-103, IEC 60870-5-104, IEEE 1588-2008 PTP.

Specify the interface, by which synchronization time correction in hours relative to the coordinated universal time are carried out (see figure 68).

```

\SW synchronization
Interface: Ethernet 1
Protocol: SNTP
Correction (h): < 3 >

Active group: Settings group 1
13.02.2022 16:02:57
  
```

Figure 68 – General view of **SW synchronization** menu

Hardware synchronization

Protocols of hardware time synchronization: PPS and IRIG-B (007).

Specify the type of synchronization and some other configurable parameters (see figure 69).

```

\HW synchronization
Sync. type: Pulse
Source: PPS from power supply
Synchropulse period (s): 1
Registered transition: front
Calibration value(ms): 0
Permissible deviation(ms): 25

Active group: Settings group 1
13.02.2022 16:02:57
  
```

Figure 69 – General view of **HW synchronization** menu

8.1.2.8.6 System time (menu item **Parameters** → **System parameters** → **System time**)

This menu provides setting the device system time: date (dd.mm.yyyy), time (hh:mm:ss).

Shifting in parameters – "▶", "◀", "▲" and "▼" buttons, parameter selection – "↵" ("ENTER"), change of a parameter by digital buttons, selection confirmation – "↵" ("ENTER") button.

Save changes – [Set], confirm selection – "↵" ("ENTER") button.

8.1.2.8.7 Threshold values (menu item **Parameters** → **System parameters** → **Threshold values**)

Threshold values menu includes:

- analog inputs;
- calculated values.

Threshold values are values, which determine the limit of signal change, in case of its excess, a report on change of signal value is sent to the upper level.

Analog inputs menu contains the name of the analog input and its limit values in modules (in percent of the nominal value - "Limit%N" and in absolute values – "LimitA.") of the analog inputs, the range of limit values. This item provides editing limit values.

Calculated values menu contains the name and limit values in modules (as a percentage of the maximum value – "Limit%" and in absolute values - "LimitA.") of the calculated value, the range of limit values. This item provides editing limit values.

8.1.2.9 Transceiver (menu item **Parameters** → **Transceiver**)

This menu item is used only in devices with the function of transmitting signals via high-frequency communication channels.

8.1.2.9.1 DTECS settings (menu item **Parameters** → **Transceiver** → **DTECS settings**)

The setting of the device for transmission of emergency and control signals (DTECS) is performed using the **DTECS settings** menu, which includes (see Figure 70): **Receiver** and **Transmitter**.

The **Receiver** and **Transmitter** menu contain:

- parameters;
- alarm;
- automatic testing;
- command table.

To enter any parameter, follow the instructions of 8.1.2.

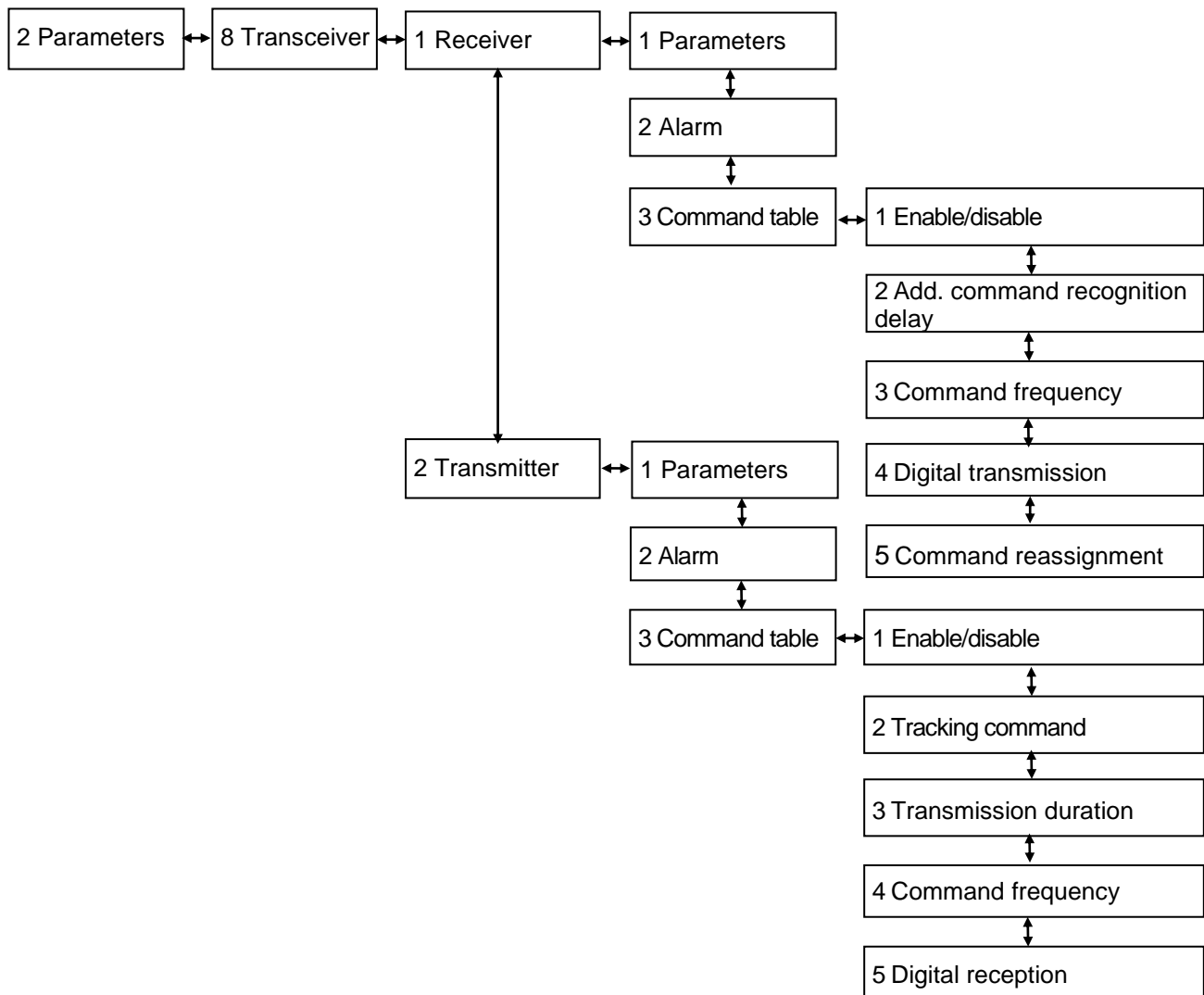

Figure 70 – **System parameters** menu structure

Parameters

The description of parameters of the receiver and transmitter of the device for transmission of emergency and control signals is provided in table 55.

Table 55 – Description of general parameters

Parameter	Permissible value	Description
Center frequency, kHz	Non-editable parameter	Displaying the center (rated) frequency of the receiver. Editing is possible only via configuration file using the Configurator software
Bandwidth, kHz	Non-editable parameter	Displaying the rated bandwidth of the receiver/transmitter. Editing is possible only via configuration file using the Configurator software
Security signal frequency, Hz	Non-editable parameter	Displaying the frequency of reception/transmission of the security signal. Editing is possible only via configuration file using the Configurator software
Telemetry frequency, Hz	Non-editable parameter	Displaying the frequency of reception/transmission of the telemetry signal. Editing is possible only via configuration file using the Configurator software
Receiver on/off	on/off	Enabling or disabling the receiver
Transmitter on/off	on/off	Enabling or disabling the transmitter
Spectrum	direct/inverted	Selecting the spectrum type for the reception/transmission frequency band. Inverted spectrum is recommended to be installed only in the transceiver with adjacent bands to reduce the influence of its transmitter on its receiver
Sensitivity, dBm	from minus 20.0 to 10.0 in increments of 0.1	Adjusting the sensitivity threshold of the receiver. The parameter determines the minimum signal level at the HF input of the receiver, at which the receiver performs its functions in compliance with normalized parameters. HF signals below the Sensitivity parameter will not be received
Attenuator 20 dB	on/off	Enabling/disabling desensitization of the receiver by 20 dB. The parameter is intended for stepwise desensitizing of the receiver by (21 ± 1) dB. It is recommended to enable the attenuator when installing the IED on short OHLs with attenuation of the HF line less than 15 dB to meet the requirements for the required attenuation margin
Receiver calibration, dB	from minus 30.0 to 30.0 in increments of 0.1	Calibrating receiver meter, in decibels (dB). The parameter is set during acceptance tests and/or commissioning and is responsible for the correctness of measurements of HF signals at the receiver input. It is used in case of discrepancy between the readings of the "SS level at HF input, dBm" meter in the "HF channel measurements" menu and the value measured using external devices at the HF input of the receiver
Telemetry	on/off	Enabling/disabling the function of reception/transmission of telemetry signals
Digital transmission	on/off	Enabling/disabling the function of digital transmission. Designed to enable and disable the function of transmitting (broadcasting) received HF commands to the digital retransmission channel via the RS-422 interface to the transmitter located at the same facility
Table continued on next page		

Parameter	Permissible value	Description
Digital reception	on/off	Enabling/disabling the function of digital reception. Designed to enable and disable the function of receiving commands using the digital retransmission channel via the RS-422 interface from the receiver for its further transmission (broadcasting) via the HF channel to the remote facility
Command level, dB	from 0.0 to 60.0 in increments of 0.1	Adjusting the command signal level at the HF output of the transmitter. The parameter is set during acceptance tests and/or commissioning and is responsible for adjusting the output power of the IED. Used to adjust the command signal to the rated level at the HF output of the transmitter in accordance with the operation manual
SS level relative to command, dB	-6 / -9 / -12	Adjusting the SS level relative to the level of the command signal at the HF output. The parameter is intended for setting the level of transmission of the security signal relative to the rated level of the command HF signal
"Tracking" command without limitation	on/off	Enabling/disabling the mode of transmission of the "tracking" command without time limit: <ul style="list-style-type: none"> – if the parameter is enabled, then the "tracking" command is transmitted without a duration limit during the time of voltage presence at its binary input; – if the parameter is disabled, then the "tracking" command is transmitted with a duration limit, i.e. during the time of voltage presence at its binary input, but not more than 3 to 15 s (the time is set in the "HF command transmission duration" parameter for the tracking command)

Alarm

Description of the parameters in **Alarm** menu is provided in table 56.

Table 56 – Description of parameters in **Alarm** menu

Parameter	Permissible value	Description
Security signal margin for warning, dB	from 0 to 30.0 s in increments of 0.1	"WARNING" alarm threshold when the margin for attenuation of the SS is reduced
Signal-to-noise ratio threshold for blocking, dB	from 0 to 20.0 s in increments of 0.1	Receiver blocking and "FAILURE" alarm threshold when signal-to-noise ratio is reduced
Signal-to-noise ratio threshold for warning, dB	from 0 to 20.0 s in increments of 0.1	"WARNING" alarm threshold when signal-to-noise is reduced
Signal-to-noise ratio blocking time, s	from 5 to 15 s in increments of 1	Receiver blocking time delay when signal-to-noise ratio is reduced below signal-to-noise ratio blocking threshold
Output level control	ena/disa	Enabling/disabling the function of signal level control at the HF output of the transmitter
Security signal threshold for warning, dBm	from 0 to 40 s in increments of 0.1	Warning alarm threshold when the SS level is reduced at the HF output of the transmitter
SS threshold for failure, dBm	from 0 to 40 s in increments of 0.1	"FAILURE" alarm threshold when the SS level is reduced at the HF output of the transmitter
Meter correction	–	Switching to the meter correction menu
Table continued on next page		

Parameter	Permissible value	Description
Voltage at HF output, V	from 0.00 to 99.99 in increments of 0.01	Sets the value of the voltage at the HF output, measured by an external device in the SS transmission mode
Current at HF output, A	from 0.000 to 0.999 in increments of 0.001	Sets the value of the current at the HF output, measured by an external device in the SS transmission mode

Command table

The menu contains the following items:

- Enable/Disable;
- Add. command recognition delay¹⁾;
- Command frequencies;
- Digital transmission¹⁾;
- Command reassignment¹⁾;
- Tracking command²⁾;
- Transmission duration²⁾;
- Digital reception²⁾.

Description of parameters in **Enable/disable** menu is given in table 57.

Table 57 – Description of parameters in **Enable/disable** menu

Parameter	Description
N	Command number
Name	Command name
Enable	Indicator of enabling/disabling the receiver/transmitter command. It is set individually for each command. When disabling the receiver command, the command reception signal is not generated in the receiver and the command output relays do not operate. When disabling the transmitter command, the command HF signal is not generated

The description of parameters in the **Add. command recognition delay** menu¹⁾ is provided in table 58.

Table 58 – Description of parameters in the **Add. command recognition delay** menu

Parameter	Description
N	Command number
Name	Command name
Value	Additional delay for recognizing the command in the receiver to improve noise immunity, in milliseconds (ms). It is set individually for each command

The description of parameters in the **Command frequency** menu is provided in table 59.

¹⁾ Only for receiver.

²⁾ Only for transmitter.

Table 59 – Description of parameters in the **Command frequency** menu

Parameter	Description
N	Command number
Name	Command name
Frequency 1 / Frequency 2	Frequency 1, in Hertz (Hz) / Frequency 2, in Hertz (Hz) Displaying frequencies of reception/transmission of command signals, in Hertz (Hz). Non-editable parameter

The description of parameters in the **Digital transmission** menu is provided in table 60.

Table 60 – Description of parameters in the **Digital transmission** menu

Parameter	Description
N	Command number
Name	Command name
Enable	Enable/disable of digital transmission of commands from receiver to transmitter (digital retransmission). It is set individually for each command

The description of parameters in the **Command reassignment** menu is provided in table 61.

Table 61 – Description of parameters in the **Command reassignment** menu

Parameter	Description
N	Command number
Name	Command name
Value	Reassigning the digital transmission command number. It is set individually for each command

The description of parameters in the **Tracking command** menu is provided in table 62.

Table 62 – Description of parameters in the **Tracking command** menu

Parameter	Description
N	Command number
Name	Command name
Tracking	Setting the tracking command mode, in which the command is transmitted during the time the voltage is present at its binary input. Only one command can be selected as tracking

The description of parameters in the **Transmission duration** menu¹⁾ is provided in table 63.

Table 63 – Description of parameters in the **Transmission duration** menu

Parameter	Description
N	Command number
Name	Command name
Value	Setting the duration of command transmission via HF channel, in milliseconds (ms)

¹⁾ Only for transmitter.

The description of parameters in the **Digital reception** menu is provided in table 64.

Table 64 – Description of parameters in the **Digital reception** menu

Parameter	Description
N	Command number
Name	Command name
Enable	Enable/disable of digital command reception (digital retransmission) for transmission to a remote facility. It is set individually for each command

8.1.2.10 Save settings (menu item **Parameters** → **Save settings**)

All changes made in parameters and settings are temporarily saved in the device RAM and are lost when the device is turned off or restarted. To save changes in the non-volatile memory, use **Save settings** menu (see figure 71).

```
\Save settings
Save settings?
Yes No

Active group: Settings group 1
13.02.2022 16:02:57
```

Figure 71 – General view of **Save settings** menu

Select **Save settings?** (Yes/No) and press "↵" ("ENTER") button. If "Yes" is selected, the screen shows the status of settings saving. There are three possible statuses: "Settings saving", "Settings saved" and "Settings saving error". In case of successful saving, the device returns to **Parameters** menu list and starts operating with new values of settings and parameters. If "No" is selected, the device returns to **Parameters** menu list without changing settings and parameters.

Settings are applied in the background mode and the device is not off.

After settings and parameters are saved in the non-volatile memory, it is necessary to make sure whether the new values are correct. If it is impossible to record (for example, in case of failure in the non-volatile memory), "ERROR" LED is on in the upper part of the device front panel.



CAUTION

When applying the module settings (**Parameters** → **System Parameters** → **Module parameters**), the device is temporarily out of operation!

8.1.3 View actual values (**Actual values** main menu item)

The actual values in the device are input analog signals, and also analog values calculated during device operation, device input binary signals and output signals of RPA function elements.

Input analog signals, calculated analog values form a group of analog signals; input binary signals and output signals of RPA function elements form a group of logic signals.

Analog signals have numeric values and can be represented with a module and an angle. Logic signals can have only two values: "0" and "1" corresponding to the presence or absence of a signal.

Actual values of analog signals, device logic signals are viewed in **Actual values** main menu item, which includes the list (see figure 72):

- inputs/outputs status;
- disturbance records;
- switching device remaining life;
- event recorder;
- measurements of HF;
- settings groups.

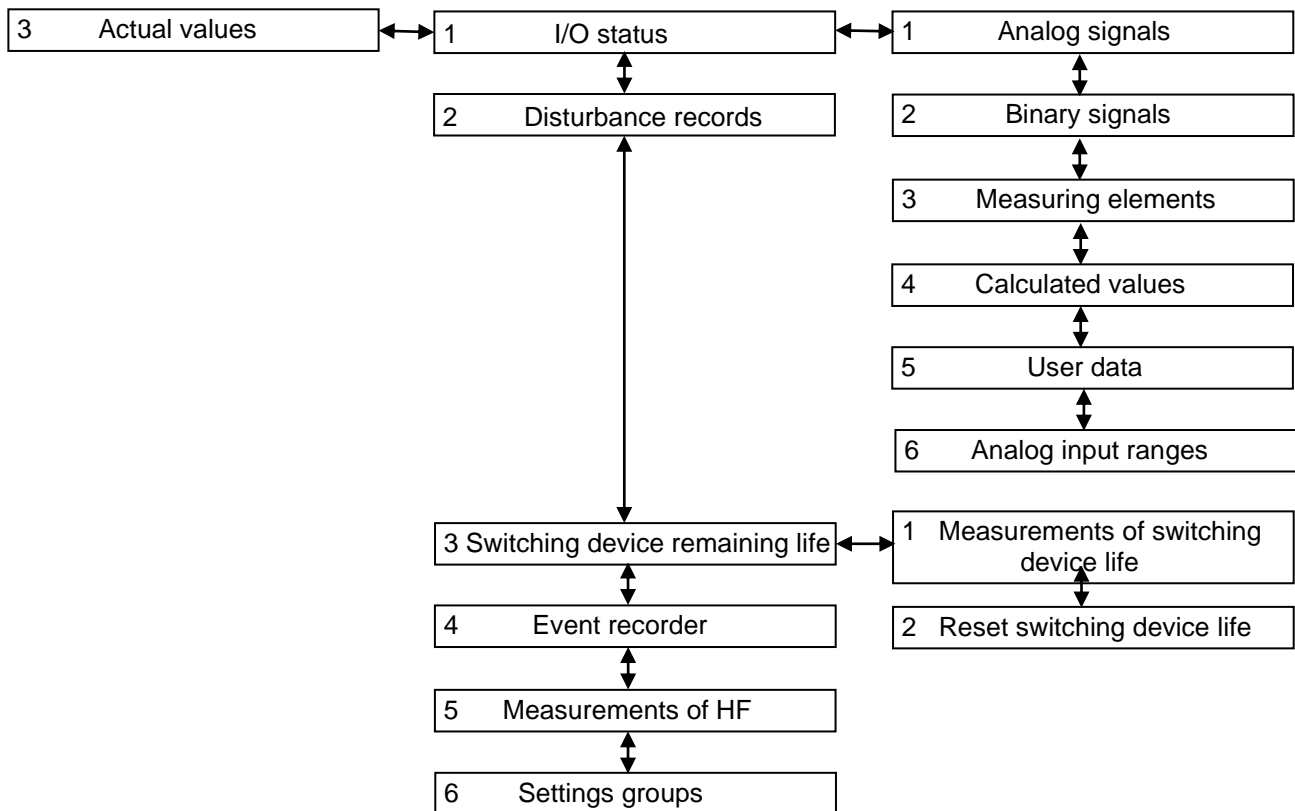

Figure 72 – Structure of **Actual values** menu

8.1.3.1 I/O status (menu item **Actual values** → **I/O status**)

The **I/O Status** menu contains:

- analog signals;
- binary signals;

- measuring elements;
- calculated values;
- user data;
- analog input ranges.

8.1.3.1.1 Analog signals (menu item **Actual values** → **I/O status** → **Analog signals**)

The **Analog signals** menu displays the name of the analog signal, its value, module of measure and angle (for AC and voltage circuits) on the display.

The analog signal value is an actual value.

When first entering, **Analog signal** menu item displays analog values calculated during operation. When pressing "Fn + 5" combination, input analog signals are displayed. After second entering, the display of analog values calculated during operation returns.

When pressing "Fn + 1" combination, a prompt is displayed.

Display of analog values:

- in relative values: "Fn + 4" combination;
- in absolute values of secondary values: "Fn + 3" combination;
- in absolute values of primary values: "Fn + 2" combination.

The value of a phasor angle of each analog signal (applicable to alternating current and voltage circuits) is determined relative to the set reference signal, which is called a basic analog signal. A reference signal is set by pressing the "↵" ("ENTER") button on the selected analog signal. The sign of selected basic analog signal is "*" displayed next to the analog signal serial number. "▲" and "▼" buttons are used for shifting.

8.1.3.1.2 Binary signals (menu item **Actual values** → **I/O status** → **Binary signals**)

Binary signals menu displays actual values of binary signals.

All device binary signals are grouped by their value (see figure 73):

- logic signals (**Logic signals** menu);
- input binary signals (**Binary inputs** menu);
- output binary signals and signaling outputs (**Binary outputs** menu);
- system state signals (**System State signals** menu).

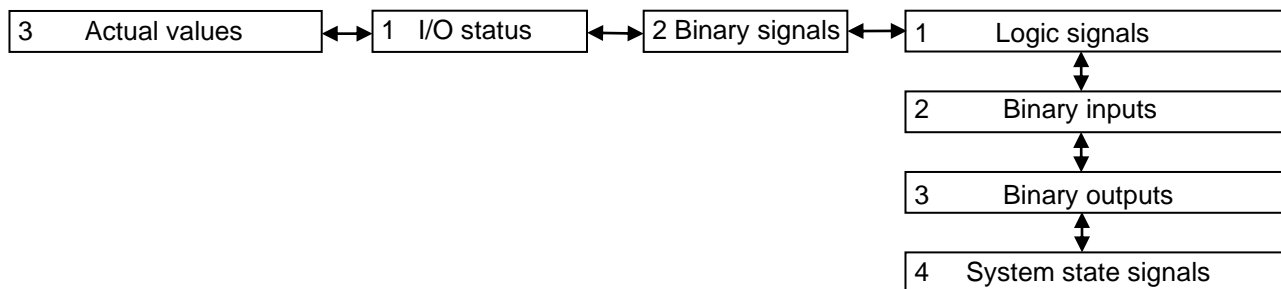

Figure 73 – Structure of **Binary signals** menu

Logic "0" or "1" are values used for binary signals, implying presence [+] or absence [] of a signal correspondingly.

Logic signals menu provides viewing values of device logic signals. The following items are displayed:

- signal No.;
- signal name;
- its value.

Binary inputs menu shows values of input binary signals grouped by modules. The following items are displayed:

- name of module of binary inputs;
- serial number of binary inputs in the module;
- name of binary input;
- its value at the current time.

"◀" and "▶" buttons enable to select a needed module of binary inputs.

Binary outputs menu displays the status values of the binary output modules and virtual modules. The following items are displayed:

- module name;
- serial number of binary output;
- name of binary output;
- its value.

"◀" and "▶" buttons enable to select a needed module.

System state signals menu displays the values of the system status signals. The following items are displayed:

- serial number of a system status signal;
- name of a system status signal;
- value of a system status signal.

8.1.3.1.3 Measuring elements (menu item **Actual values** → **I/O status** → **Measuring elements**)

Measuring elements menu provides display of settings value, actual values of input analog signals of measuring element, measuring element outputs, and calculated analog values of measuring element.

If the number of measurements is greater than it can be displayed, the vertical scroll stripe appears to the right, and "▲" and "▼" are used for shifting. Protection for information output on the screen is selected by "◀" and "▶" buttons.

By pressing the combination of buttons "Fn + 3" the display shows the measurements in primary values, and by pressing the buttons "Fn + 4" the values are displayed in secondary values.

The status of the measuring elements devices is displayed on LEDs ("1 - 8") automatically, except for devices of 1/3 19" design.

8.1.3.1.4 Calculated values (menu item **Actual values** → **I/O status** → **Calculated values**)

Calculated values menu provides viewing values of calculated expressions set in the configurations. Calculated values can be displayed on the mimic diagram, and transferred to PCS. There is an option to simulate pointer indicators, i.e. integration of a value of a calculated expression with set measurement rate. More detailed information on working with calculated values is given in the document "EKRASMS-SP software package".

8.1.3.1.5 User data (menu item **Actual values** → **I/O status** → **User data**)

User data menu provides access to data of various formats under Modbus protocol in the device regardless of its configuration. This item displays the following information on user data (see figure 74):

- serial number of a user data component;
- name of a user data component;
- actual value of a user data component;
- time of last change.

```
\User data
1  CMD_KA2on
   0
   13:02:22:013 13.02.2022
2
Active group: Settings group 1
13.02.2022 16:02:57
```

Figure 74 – General view of **User data** menu item

8.1.3.1.6 Analogs inputs ranges (menu item **Actual values** → **I/O status** → **Analogs inputs ranges**)

This menu item (figure 75) provides selection of one of the proposed measured ranges of the analog inputs of the device. 6 measuring ranges are available for AC channels, 2 measuring ranges are available for AC voltage channels. Range selection affects the measurement limits of analog signals.

```

\Analog inputs ranges
<1/6>
Analog inputs name:
I Y A, B, C
Sensor output D2976:
~I1(A), ~I2(A), ~I3(A),
Ranges:
  N   Input   Min           Max           Output
( ) 1    0.15    0.0075        6            2.3
( ) 2    0.3     0.015         12           2.3
( ) 3    0.5     0.025         20           2.4
( ) 4    1       0.05          40           2.4
( ) 5    2.5     0             100          2.4
( ) 6    5       0.25          200          2.4
13.02.2022 16:02:57

```

Figure 75 – General view of **Analog inputs** menu

8.1.3.2 Disturbance records (menu item **Actual values** → **Disturbance records**)

Disturbance records menu (see figure 76) is intended for viewing information on disturbance records, which are currently present in the device: disturbance record name, date/time of creation and protection. Since there are new disturbance recordings, old ones are deleted, then the user can protect the selected disturbance record from being overwritten by setting the value [*] in the "Protect" column.

```

\Disturbance records
Name: term
Number           Date/Time           Protect
b0101003.a00    00.00.00 00:00    [*]
b0101003.a01    00.00.00 00:00    [*]
XXXXXXXXXXXXXXX 00.00.00 00:00    [*]
XXXXXXXXXXXXXXX 00.00.00 00:00    [ ]
XXXXXXXXXXXXXXX 00.00.00 00:00    [ ]
XXXXXXXXXXXXXXX 00.00.00 00:00    [ ]
XXXXXXXXXXXXXXX 00.00.00 00:00    [ ]
XXXXXXXXXXXXXXX 00.00.00 00:00    [ ]
XXXXXXXXXXXXXXX 00.00.00 00:00    [ ]
XXXXXXXXXXXXXXX 00.00.00 00:00    [ ]
XXXXXXXXXXXXXXX 00.00.00 00:00    [ ]
XXXXXXXXXXXXXXX 00.00.00 00:00    [ ]
Active group: Settings group 1
13.02.2022 16:02:57

```

Figure 76 – General view of **Disturbance records** menu

8.1.3.3 Switching device remaining life (menu item **Actual values** → **Switching device remaining life**)

Switching device remaining life menu contains:

- measurements of switching device life;
- reset switching device life.

8.1.3.3.1 Measurements of switching device life (menu item **Actual values** → **Switching device remaining life** → **Measurements of switching device life**)

Information on actual switching device status (see figure 77).

Residual life – current residual life by each phase, considering operations by switch on and switch off of load currents and SC currents.

Table of closings – quantity of closings by each phase on specified current of switch on /on. And also, total quantity of closings by each phase.

Table of openings – quantity of openings by each phase on specified current of switch off /off. And also, total quantity of openings by each phase.

If the quantity of commutations of a switching device is greater than it can be displayed, the vertical scroll stripe appears to the right, and "▲" and "▼" are used for shifting. Switching device selection: "◀" and "▶" buttons.

```
\Measurements of switching device life
Switching device: <1/9> CB
Remaining life, %
ph.A      ph.B      ph.C
100.0     100.0     100.0
Q-ty of closing:
N      Iclose.,kA  ph.A  ph.B  ph.C
1      0.000      0     0     0
2      0.000      0     0     0
Total  0            0     0     0
Q-ty of openings:
N      Itrip.,kA  ph.A  ph.B  ph.C
1      0.000      0     0     0
Active group: Settings group 1
13.02.2022 16:02:57
```

Figure 77 – General view of **Measurements of switching device life** menu

8.1.3.3.2 Reset switching device life (menu item **Actual values** → **Switching device remaining life** → **Reset switching device life**)

When entering the menu, a security password is requested, enter a combination of symbols, which is a password, and press the "↵" ("ENTER") button.

Reset switching device life menu (see figure 78) is used to reset the switching device life calculation without settings saving.

```
\Reset switching device life
N Name                               Select
1 Switch control 1                   [ ]
[ Clear selected ]

Active group: Settings group 1
13.02.2022 16:02:57
```

Figure 78 – General view of **Reset switching device life** menu

8.1.3.4 Event recorder (menu item **Actual values** → **Event recorder**)

Event recorder menu is intended to display the device event recorder events.

This menu displays the following information on the event (see figure 79):

- event time and date;
- signal name;
- signal status at the specified time.

Pressing a combination of "Fn + 2" buttons will change the information display – the display will be without the group number and event number.

Note – the group number corresponds to the following conditions:

- 1 – state of bits of the function processor;
- 2 – matrix inputs;
- 3 – binary inputs;
- 4 – measuring elements enable/disable;
- 5 – matrix outputs;
- 6 – system status.

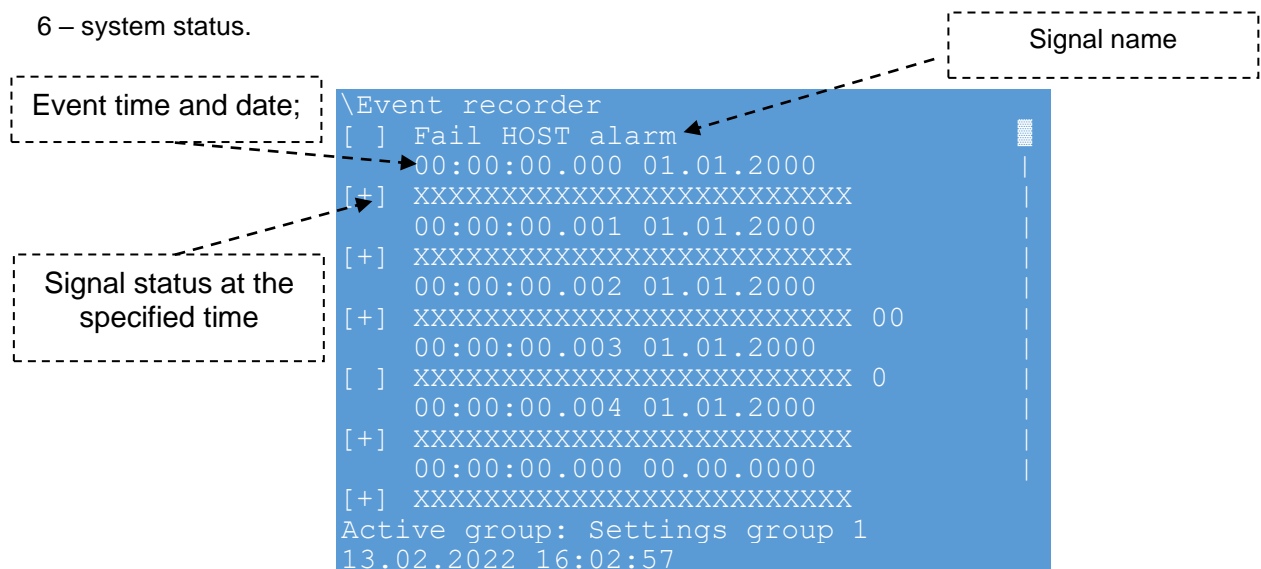

Figure 79 – General view of **Event recorder** menu

Pressing the combination of "Fn + 2" buttons displays on the screen the group of each event and the sequence number of the signal.

8.1.3.5 Measurements of HF (menu item **Actual values** → **Measurements of HF**)

This menu item is used only in devices with the function of transmitting signals via high-frequency communication channels.

Measurements of HF menu is used to view the measurements of HF.

Measurements of HF menu is displayed only for devices with the "Communication device" functionality, otherwise the message "No data to display" is displayed on the screen.

Description of parameters in the **Measurements of HF** menu is given in table 65.

Table 65 – Description of parameters in the **Measurements of HF** menu

Parameter	Description
Security signal level at HF input, dBm	Level of security signal at HF input
Command signal level, dBm	Command signal level at HF input. It is determined by the difference between the set command level and the actual level of the security signal
Noise level at 4 kHz, dBm	Level of noise in operating 4 kHz band
SS level margin, dB	Estimated margin of the security signal level. Margin is determined as the difference between the SS level at the HF input and sensitivity
Command level margin, dB	Estimated margin of the command level. Margin is determined as the difference between the estimated level of the command signal at the HF input and sensitivity
Signal-to-noise ratio margin, dB	Estimated margin of the SNR level. Margin is determined as the difference between the estimated level of SNR and the SNR threshold for blocking
Signal-to-noise ratio level, dB	Estimated level of SNR. SNR level is determined as the difference between the estimated level of the command signal and noise level in the 4 kHz band
Voltage at HF output, V	Voltage at the HF output of the IED, measured by the built-in voltage meter
Current at HF output, A	Current at the HF output of the IED, measured by the built-in current meter

8.1.3.6 Settings groups (menu item **Actual values** → **Settings groups**)

For operating switching of settings required for a protected facility, settings groups are implemented. In each group, the setting of individual settings for measuring devices, logic elements, a trip matrix and calculated values is implemented, all other parameters (hardware settings, PCS, etc.) are the same for all settings groups. The maximum quantity of settings groups is eight, only one of them can be active at once. The menu provides viewing the quantity of settings groups and the active settings group.

8.1.4 Viewing self-diagnostic results (main menu item **Diagnostic**)

During the device operation, failure detected by the device supervision system, can arise. This menu item displays the actual status of the device modules, the status of communication ports, and general device status at the moment of viewing.

8.1.4.1 State of modules (menu item **Diagnostic** → **State of modules**)

State of modules item displays a state of modules in the form of a table: "OK", "Warning" or "Faulty" (see figure 80) Detailing of failure causes is available for a logic module. Viewing of detailing of failure causes – the "↵" ("ENTER") button, repeated pressing resets the state of modules. By pressing the "Fn + 7 + 9" buttons one can open more detailed information (see figure 81).

```

\State of modules
Name      Type      State
A1-A-E1   L2571    Warning
A1-A-E2   PU1602   OK
A1-A-E3   R1630    OK
A1-A-E4   R1630    OK
A1-A-E5   R1630    OK
A1-A-E10  D2807    Faulty
A1-A-E11  D2976    Faulty
A1-A-E12  D3032    OK
A1-A-E9   EI2582   OK
A1-A-E8   EI2582   OK
A1-A-E7   EI2582   OK
Active group: Settings group 1
13.02.2022 16:02:57

```

Figure 80 – General view of **State of modules** menu

```

\State of module
Name      Type      State   CRC   CodeReset
A1-A-E1   L2571    OK      ----
A1-A-E2   PU1602   0x0000  0     0     0
A1-A-E3   R1630    0x0000  0     0     0
A1-A-E4   R1630    0x0000  0     0     0
A1-A-E5   R1630    0x0000  0     0     0
A1-A-E10  D2807    0x0000  0     0     0
A1-A-E11  D2976    0x0000  0     0     0
A1-A-E12  D3032    0x0000  0     0     0
A1-A-E9   EI2582   0x0000  0     0     0
A1-A-E8   EI2582   0x0000  0     0     0
Service counter of DSP:0
Active group: Settings group 1
13.02.2022 16:02:57

```

Figure 81 – General view of **State of module (detailed information)** menu

8.1.4.2 State of communication (menu item **Diagnostic** → **State of communication**)

State of communication menu displays quantitative parameters of the selected communication protocol (see figure 82). Selection of communication protocol: "◀" and "▶" buttons.

```

\State of communication
Protocol: 61850 GOOSE
Outgoing : 1
MAC : 01-0c-cd-01-00-3f
Applet ID : 51
GOOSE ID : 1
Sent : 430387
stNum : 48
Sending errors : 0
Max. sending time : 510
Min. sending time : 53
Averege sending time : 93
Active group: Settings group 1
13.02.2022 16:02:57

```

Figure 82 – General view of **State of communication** menu

Possible parameters of selected communication protocol are given in table 66.

Table 66 – Parameters of communication protocols

Parameter	Note
Symbols received	Quantity of symbols received
Symbols sent	Quantity of symbols sent
Packets received	Quantity of packets received
Packets sent	Quantity of packets sent
Time of the last packet	Time of the last packet
Q-ty of connected clients	Quantity of connected clients
Q-ty of free connections	Quantity of free connections
Q-ty of servers	Quantity of servers
Active server	Which server is active
Server IP address	Server IP address
Client No.	Client serial number
Client	Quantity of clients
Client IP address	Client IP address
Time diff, ms	Time difference between client (device) and server (time source) in milliseconds
Request processing by server, ms	Time for inquiry processing by server in milliseconds
Response wait by client, ms	Wait time for response time by client in milliseconds
Summer time feature	1 – summer, 0 – winter
Last sync time	Time of receiving last time synchronization command in hh:mm dd.mm.yy format
Latest received time	Latest time received from server
Max. quantity of MMS clients	Maximum quantity of MMS clients
Connect requests	Quantity of requests for connection
Connect confirmations	Quantity of connection confirmations
Connect errors	Quantity of connection errors
MMS packets received	Quantity of MMS packets received
MMS packets sent	Quantity of MMS packets sent
Receiving/processing errors	Quantity of errors of receiving/processing
Preparation/sending errors	Quantity of errors of preparation/sending
Outgoing	Signals, actual values of which are to be transmitted to other devices
MAC	Broadcast MAC address, where GOOSE packets are sent to
Applet ID	Application identifier, using a distribution
GOOSE ID	GOOSE identifier (string)
Received	Quantity of signals received
Sent	Quantity of signals sent
stNum	Sequence number
Max. receiving time	Maximum receiving time
Min. receiving time	Minimum receiving time
Table continued on next page	

Parameter	Note
Average receiving time	Average receiving time
For other devices	Counter of packets designed for other devices. During packet decoding, a configuration mismatch was detected (for example, the GOOSE ID in the received packet does not match the configuration)
Test packets received	Quantity of packets received with the Test flag set (test packets)
Decoding errors	Quantity of decoding errors
Skipped packets	Counter of skipped packets. Increases if the difference between the previous and current value of the sqNum field is greater than one
Not in time	Counter of packets that did not arrive on time (timeAllowedToLive (time to live") timed out, but a new packet is not received)
Sending errors	Quantity of sending errors
Max. sending time	Maximum sending time
Min. sending time	Minimum sending time
Average sending time	Average sending time

8.1.4.3 IED state (menu item **Diagnostic** → **IED state**)

IED state menu displays general information on the device status (table 47).

8.1.4.4 Synchronization (menu item **Diagnostic** → **Synchronization**)

Synchronization menu includes parameters:

- presence/absence of synchronization via PTP;
- error configuration Ethernet redundancy module;
- synchronization time;
- quantity of synchronization requests;
- quantity of repeated requests;
- maximum repetitions per request.

8.1.5 Test (item of **Tests** main menu)

Tests menu item provides an option to test operation of system components and it has the following items (see figure 83):

- test of modules;
- autotest;
- keyboard test;
- testing of transmission HF commands;
- testing of reception HF commands.

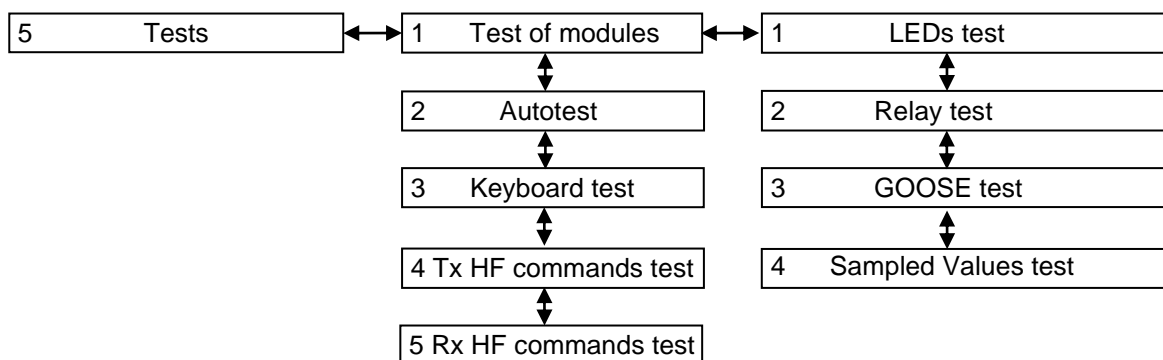

Figure 83 – Structure of **Tests** menu

When entering the menu, a security password is requested, enter a combination of symbols, which is a password, and press the "↵" ("ENTER"). After that the device switches to "TEST" operation mode.

When escaping **Test** menu, automatic reset from the "TEST" device operation mode occurs.

8.1.5.1 Test of module (menu item **Tests** → **Test of module**)

8.1.5.1.1 LEDs test

In this menu, LEDs can be turned on and off on the device front panel for visual control of led glowing.

When pressing "Fn + 1" combination, a prompt is displayed.

Pressing "Fn + 2" buttons displays cyclic LED test in the following order:

- red light glowing;
- green light glowing.

Pressing "Fn + 3" buttons displays cyclic LED test in the following order:

- separate LEDs;
- A columns – G LEDs.

The "↵" ("ENTER") button provides switching on ([+])/off ([]) LEDs.

When escaping **LEDs test** menu, automatic reset from the "TEST" device operation mode occurs.

8.1.5.1.2 Relay test

In this menu, test excitations of some relays are possible, thus, test of signal passage of all communication circuit from the device to the control point.



CAUTION

When issuing test excitations to the device relays, operating equipment can be turned off!

Ensure safety before issuing test excitations!

When pressing "Fn + 1" combination, a prompt is displayed.

Pressing "Fn + 3" buttons displays cyclic relay test in the following order:

- specific relays;
- relay modules (binary output modules).

The "↵" ("ENTER") button provides switching on ([+])/off ([]) relays/relay modules.

When escaping **Relay test** menu item, automatic reset from the "TEST" device operation mode occurs.

8.1.5.1.3 GOOSE test

This menu issues GOOSE messages with "test" mark to test passage of GOOSE messages via Ethernet network from the device to the control point. In the control point, the device must be switched to "TEST" status.

Pressing "Fn + 3" buttons selects a mode of sending GOOSE messages: one by one or all at once.

Pressing the "↵" ("ENTER") button sends the GOOSE message depending on the selected mode.

8.1.5.1.4 Sampled Values testing

This menu provides enabling/disabling the Sampled Values test mode. This function is applicable only to those devices that operate using the protocol IEC 61850-9-2.

8.1.5.2 Autotest (menu item **Tests** → **Autotest**)

This menu provides enabling/disabling the automatic testing of the device for the operator through the front panel or application software for working with special software (**TestSuite** program) and test complexes according to pre-recorded test programs. The autotest mode is necessary for testing the protective functions of devices (settings, time delays and logic elements) with the use of a control relay (if such a relay is present in the device).

8.1.5.3 Keyboard test (menu item **Tests** → **Keyboard test**)

This menu is intended for testing the device keyboard. Testing is carried out by alternately pressing the keys, with the control of the appearance of a message about pressing on the front panel of the device.

8.1.5.4 Testing of transmission HF commands¹⁾ (menu item **Tests** → **Tx HF commands test**)

This menu is for testing the transmission of high frequency commands. This menu item is used only in devices with the function of transmitting signals via high-frequency communication channels.

8.1.5.5 Testing of reception HF commands¹⁾ (menu item **Tests** → **Rx HF commands test**)

This menu is intended for testing the device keyboard. This menu item is used only in devices with the function of transmitting signals via high-frequency communication channels.

¹⁾ This menu is displayed only for devices with the functionality of "Communication device", otherwise the message "No data to display" is displayed on the screen.

8.1.6 Mimic diagram (main menu item **Mimic diagram**)

Mimic diagram menu can display a part of the main diagram with protected objects, commutating equipment, values of actual electrical parameters of the protected object or connection, status indicators (for example, place of management, portable earthing).

In the mimic diagram, elements issuing excitations of status change by a controlled object can be set (circuit breakers, disconnectors, software buttons, etc.). To enter the control mode, access rights are obligatory to perform this operation.

Mimic diagram menu displays the actual state of objects in enabled and disabled control mode. In enabled control mode, authorized user's login is displayed in the status line (see figure 84).

If there is a function of interlocking of a switching device, to designate status of permission to control switching devices, a "lock"  symbol is used. Closed "lock" – control is blocked, no "lock" symbol – control is permitted.

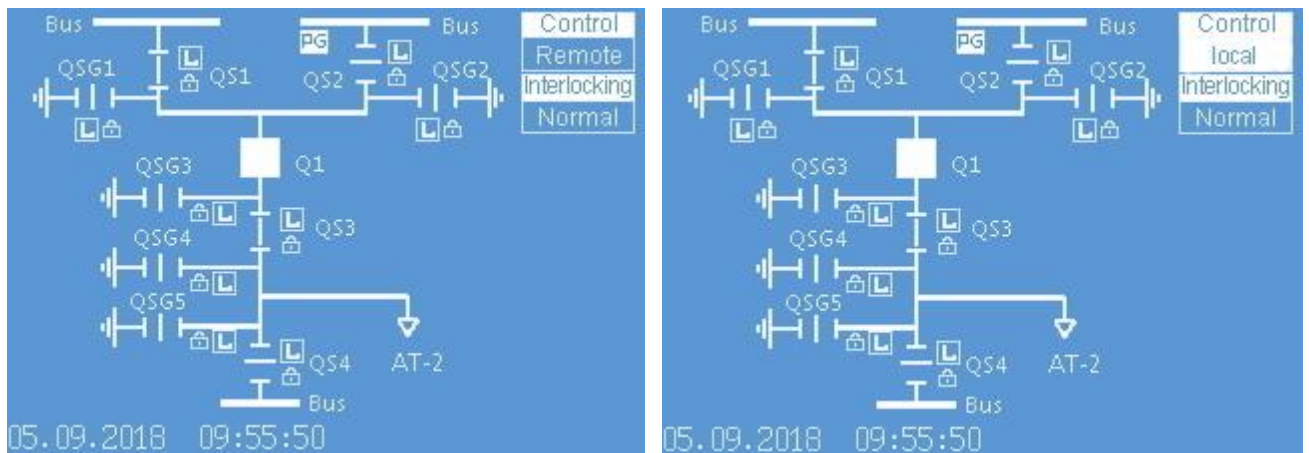

a) disabled local control mode

b) enabled local control mode

Figure 84 – General view of **Mimic diagram** menu

Object control

Depending on the method of switching to the local control mode (via binary input, electronic switch or other), this action provides switching to the control mode of objects (switching devices). Access to this mode is permitted only after entering a password. Using digital buttons, enter a combination of symbols, which is a password (see figure 85), and press the "↵" ("ENTER") button.

When pressing "Fn + 1" combination, a prompt is displayed.

```

\User authorization
(Esc - view mode,
Left - delete symbol)
Switching to local control mode.
Enter password:
****

Active group: Settings group 1
13.02.2022 16:02:57

```

Figure 85 – Switching to the control mode

"▲" and "▼", "◀" and "▶" buttons are used to select a controlled object.

User procedure (see Figure 86):

"Select action" (window No.1) → "Confirm action" (window No.2).

When pressing the "↵" ("ENTER") button, a dialog window (window No.1) of action selection appears on the selected object. The dialog window contains information about available commands and control buttons.

The procedure is shown on the example of switching device control. To enable a switching device, press "I" button, to disable, press "O" on the device keyboard. To cancel control, press "ESC" button.

In case of attempt to control a switching device, an inquiry to confirm action appears on the device screen (window No.2). To confirm the inquiry, press "↵" ("ENTER") on the device keyboard, to reject control – "ESC".

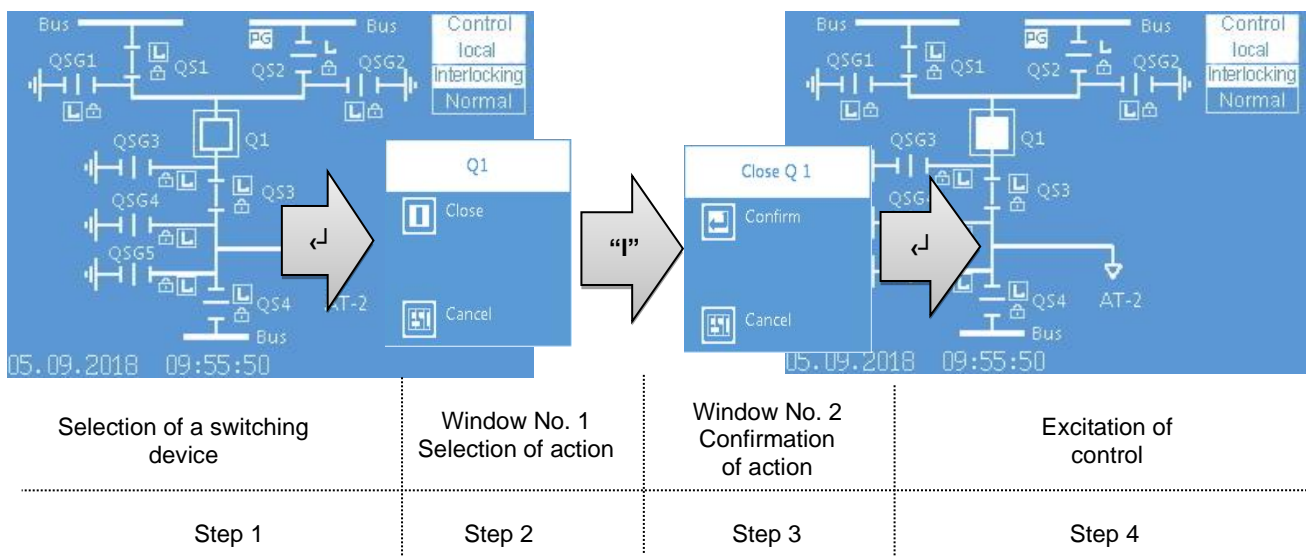

Figure 86 – Example of circuit breaker control

Exit the mimic diagram control mode and reset of access level are carried out by repeated pressing "Fn + 2" combination, "ESC" button or it is carried out automatically via adjustable time delay (10 minutes by default).

8.1.7 Operation with service menu (main menu item **Service menu**)

Service menu contains (see figure 87):

- switch to recovery mode;
- actual values;
- ADC calibration.

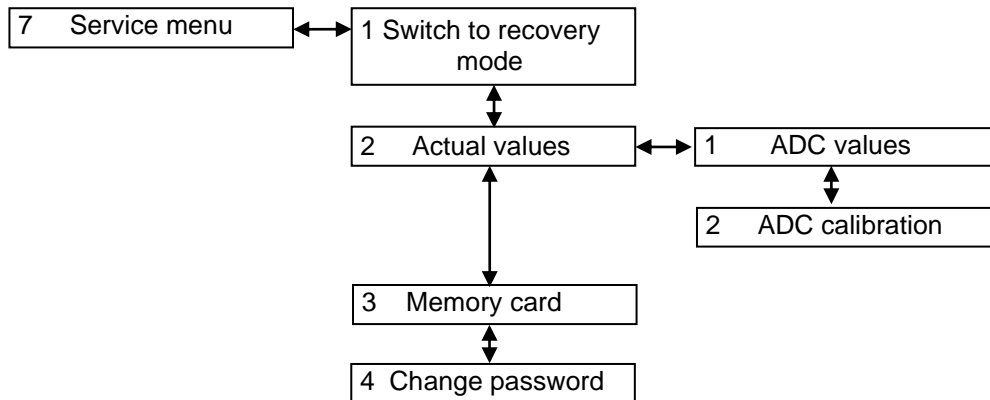

Figure 87 – Structure of **Service menu**

8.1.7.1 Software recovery mode (menu item **Service menu** → **Switch to recovery mode**)

This mode is used to recover operability of the device software. This mode provides:

- reset to previous software version;
- update software;
- view information of software files (previous, current and factory software) and configuration set (factory, previous and current configuration);
- view communication parameters;
- system reset.

The device in the recovery mode contains the following submenus:

- information;
- communication parameters;
- service functions;
- system reset;
- language.

System reset is a function that reinitializes all components (modules) of the device.

8.1.7.2 Actual values (menu item **Service menu** → **Actual values**)

Actual values menu contains the items:

- ADC measurements;
- ADC calibration.

8.1.7.2.1 ADC measurements (menu item **Service menu** → **Actual values** → **ADC measurements**)

ADC measurements menu is designed to view voltages of ADC sensor channels and it is used for control and manual calibration of analog inputs. Data of ADC channels are displayed in the uncalibrated form. Each sensor is provided with display of 26 ADC channels (Ch_01 – Ch_26) and two additional channels (TstCh_1, TstCh_2), which display the value of power supply sources plus 12 V and minus 12 V. “◀” and “▶” buttons enable to select a needed module of analog inputs.

As the number of channels is greater than it can be displayed, the vertical scroll stripe is located on the right, and “▲” and “▼” are used for shifting.

8.1.7.2.2 ADC calibration (menu item **Service menu** → **Actual values** → **ADC calibration**)

ADC Calibration menu contains the following submenus:

- ADC ratios;
- zero offset.

For each analog input, an ADC ratio and zero offsets are set separately for each of the channels.

1) ADC ratios (menu item **Service menu** → **Actual values** → **ADC calibration** → **ADC ratios**)

ADC ratios menu (see Figure 88) is designed for correction of analog signal module, read from ADC, and it is determined by relation of the values of the signal transmitted to the analog input and displayed on the device screen if the ADC ratio is equal to 1.

```
\ADC ratios
Module: <1/2> E12 D26811
Range: <1/1>
Auto[ ]View[ ]
Signal Supply   Accura  New   Hight-setNew
c42 A   5.00 A   >1.0  [ ] >1.0  [ ]
c43 A   5.00 A   >1.0  [ ] >1.0  [ ]
c44 A   5.00 A   >1.0  [ ] >1.0  [ ]
c45 A   5.00 A   >1.0  [ ] >1.0  [ ]
c46 A   5.00 A   >1.0  [ ] >1.0  [ ]
c47 A   5.00 A   >1.0  [ ] >1.0  [ ]
c40 A  12.00 V   >1.0  [ ] >1.0  [ ]
c48 A  12.00 V   >1.0  [ ] >1.0  [ ]
Active group: Settings group 1
13.02.2022 16:02:57
```

Figure 88 – General view of **ADC ratios** menu

2) Zero offsets (menu item **Service menu** → **Actual values** → **ADC calibration** → **Zero offsets**)

Zero offsets menu (see Figure 89) contains the actual zero offset values for the analog modules. The selection of the analog input module is carried out using the "Fn + ◀", "Fn + ▶" buttons. The device allows you to display the help window using the combinations of buttons "Fn + 1", return - "ESC".

Offset (Zero offset ratio) – average signal value on ADC output when there are no input signals.

The automatic adjustment of ADC zero offset is performed during the factory settings of the device.

Automatic calculation of the ratios is carried out, among other things, through the Smart Monitor program: Service menu / ADC calibration / Ratios.

```
\Zero offsets
Module: <1/1> E12 D26811
Range: <1/1>
[Record all]      [Calculate all]
N   Accurat New  High-set New
1   0           [ ] 0       [ ]
2   0           [ ] 0       [ ]
3   0           [ ] 0       [ ]
4   0           [ ] 0       [ ]
5   0           [ ] 0       [ ]
6   0           [ ] 0       [ ]
7   0           [ ] 0       [ ]
8   0           [ ] 0       [ ]
Active group: Settings group 1
13.02.2022 16:02:57
```

Figure 89 – General view of **Zero offsets** menu

8.1.7.3 Memory card (menu item **Service menu** → **Memory card**)

This service menu is for internal use. For example, in this menu, it is possible to check values of registers read under Modbus/RTU and Modbus TCP/IP protocols when using protection functions.

8.1.7.4 Change password (menu item **Service menu** → **Change password**)

This menu item allows you to change the password of the user who was authorized when entering this menu item.

8.1.8 Operation mode (main menu item **Operation mode**)

Operation Mode menu (see figure 90) allows you to programmatically change the operation mode of the device, as well as enable or disable simulation mode. Simulation mode can be used in any mode of operation of the ED2.

```
\Operation mode
Name                Val.
On                  [+ ]
Blocked             [ ]
Test                [ ]
Test/blocked        [ ]
Off                 [ ]

Simulation mode:    Disabled

Active group: Settings group 1
13.02.2022 16:02:57
```

Figure 90 – General view of **Operation mode** menu

The following device modes are available:

- On;
- Blocked;
- Test;
- Test / blocked;
- Off.

– When switching from one mode to another, the quality attributes for incoming and outgoing GOOSE messages and MMS reports change. The parameters of each mode are shown in table 67.

Table 67 – Device operating modes

Device operation mode	Operating mode parameters
On	<ol style="list-style-type: none"> 1. Data objects in incoming GOOSE messages are accepted only if the "Test" quality attribute in them is set to FALSE. 2. Data objects in outgoing GOOSE messages are sent with the "Test" quality attribute set to FALSE. 3. Data objects in MMS reports are sent with the "Test" quality attribute set to FALSE. 4. Control commands via MMS are accepted only if the "Test" attribute in them has the value FALSE (otherwise, they are rejected with the explanation "blocked-by-mode"). 5. The output relays of the terminal operate normally.
Blocked	<ol style="list-style-type: none"> 1. Data objects in incoming GOOSE messages are accepted only if the "Test" quality attribute in them is set to FALSE. 2. Data objects in outgoing GOOSE messages are sent with the "Test" quality attribute set to FALSE. 3. Data objects in MMS reports are sent with the "Test" quality attribute set to FALSE. 4. Control commands via MMS are accepted only if the "Test" attribute in them has the value FALSE (otherwise, they are rejected with the explanation "blocked-by-mode"). 5. At the moment of switching to the blocked mode, the states of the output relays are fixed and do not change their position until this mode is removed (the relays are "frozen")
Test	<ol style="list-style-type: none"> 1. Data objects in incoming GOOSE messages are accepted regardless of the value of their "Test" quality attribute. 2. Data objects in outgoing GOOSE messages are sent with the "Test" quality attribute set to TRUE. 3. Data objects in MMS reports are sent with the "Test" quality attribute set to TRUE. 4. Control commands via MMS are accepted only if the "Test" attribute in them is set to TRUE (otherwise, they are rejected with the explanation "blocked-by-mode"). 5. The "Automatic testing" mode is active.
Test / blocked	<ol style="list-style-type: none"> 1. Data objects in incoming GOOSE messages are accepted regardless of the value of their "Test" quality attribute. 2. Data objects in outgoing GOOSE messages are sent with the "Test" quality attribute set to TRUE. 3. Data objects in MMS reports are sent with the "Test" quality attribute set to TRUE. 4. Control commands via MMS are accepted only if the "Test" attribute in them is set to TRUE (otherwise, they are rejected with the explanation "blocked-by-mode"). 5. At the moment of switching to the blocked mode, the states of the output relays are fixed and do not change their position until this mode is removed (the relays are "frozen"). 6. The "Automatic testing" mode is active.

Table continued on next page

Device operation mode	Operating mode parameters
Off	<ol style="list-style-type: none"> 1. Data objects in incoming GOOSE messages are accepted only if the "Test" quality attribute in them is set to FALSE. 2. Data objects in outgoing GOOSE messages are sent with the "Validity" quality attribute set to INVALID. 3. Data objects in MMS reports are sent with the "Validity" quality attribute set to INVALID. 4. MMS control commands are rejected (with the explanation "blocked-by-mode"). 5. Changing the operating mode of the terminal through the Mod data object and through the display of the terminal must remain available. 6. Output relays are de-energized (Uout removed).
Notes on operating modes	<ol style="list-style-type: none"> 1. "Quality attribute "Test"" - attribute q.test for EACH signal. The Test field in the GOOSE message header in revision 2.0 and later of the 61850 standard has been renamed Simulation and can no longer be used to designate test messages. 2. For data objects Mod, Beh, Health the test bit is not used (always q.test = FALSE).

Simulation mode.

When the simulation mode is enabled in the logical node of the physical device LPHD1, the Sim data object takes the value TRUE, when disabled, FALSE.

Figure 91 shows a device receiving two GOOSE messages at the same time (GOOSE 1). The GOOSE message from the test set has the simulation bit set to TRUE in the header, while the other GOOSE 1 message sent by the real device has the simulation bit set to FALSE. The IED1, where the LPHD1 physical device logical node Sim has the value TRUE, will only process the GOOSE 1 message from a valid source until a message from the test set has appeared on the network. Further, the IED1, where the data object Sim is TRUE in the physical device logical node LPHD1, will only process the GOOSE 1 message from the test set. A valid GOOSE 1 message will not be processed until the Sim value of logical node LPHD1 is set to FALSE.

Although the Sim data object in the logical node LPHD1 remains TRUE, the other two messages GOOSE 2 and GOOSE 3, with simulation bits set to FALSE, will still be processed according to IEC 61850 as shown in figure 91, because there are no other GOOSE 2 or GOOSE 3 messages with the simulation bit set to TRUE on the network. As soon as a GOOSE 2 or GOOSE 3 message appears on the network that has the simulation bit set to TRUE, the device will subscribe to that GOOSE message.

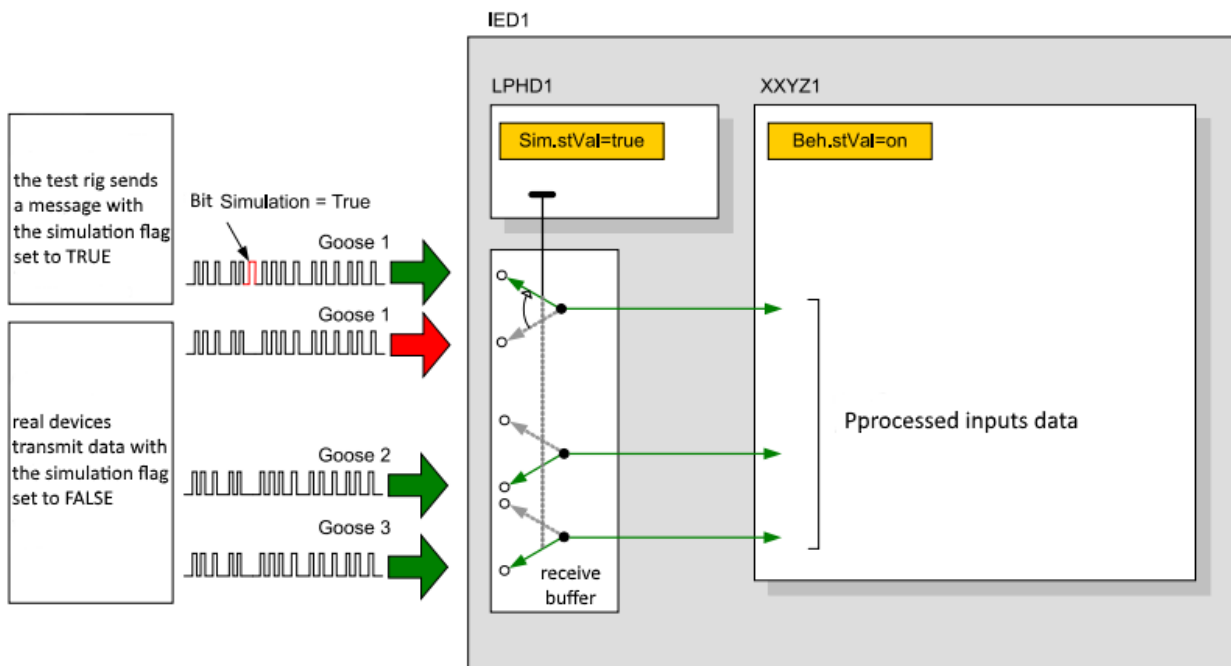

Figure 91 – Data used to receive simulation signals

8.1.9 Working with USB flash drive (main menu item **USB drive**)

For working with **USB drive** menu item, insert the USB-flash drive into the corresponding socket of the device.

USB drive menu contains submenus:

- saving files to send;
- saving disturbance records;
- update;
- memory state;
- formatting;
- save documentation;
- save settings report.

8.1.9.1 Save files for sending (menu item **USB drive** → **Save files for sending**)

Files for sending contain: configuration file (*.arh), program file (core.arh), LOG folder with all contents (see figure 92).

To save files for sending, press the "↵" ("ENTER") button on the **Save** item. The menu also contains information about the amount of memory required for recording on the USB flash drive and the amount of free memory on it.

The files will be copied to the \\EKRA\Configuration name*\ToMail_YYYYMMDD_hhmmss, where YYYYMMDD is the save date, hhmmss is the save time.

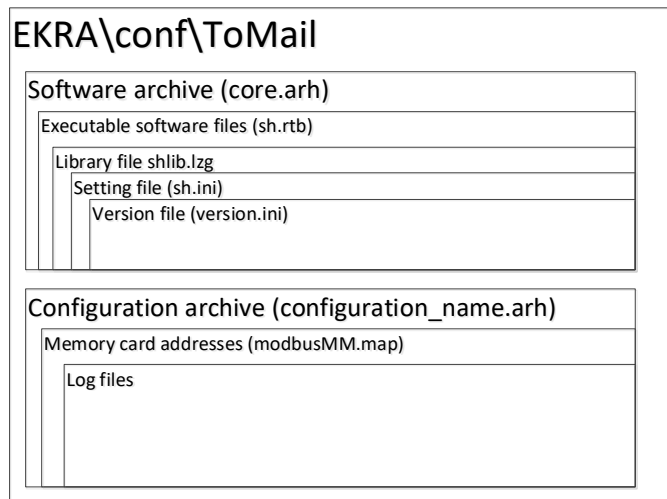

Figure 92 – EKRA\conf\ToMail folder structure

8.1.9.2 Saving disturbance records (menu item **USB drive** → **Save disturbance records**)

This menu is intended for saving disturbance records recorded by the device to an external USB flash drive.

The menu allows you to select the format for saving disturbance records:

- archive (*.aNNNN);
- Comtrade (*.cfg, *dat, *hdr).

Setting/resetting the format is carried out with the "↵" ("ENTER") button.

To save the disturbance records, press the "↵" ("ENTER") button on the **Save** item. The menu also contains information about the amount of space required for recording on the USB flash drive and the amount of free memory on it.

All disturbance records (files with the *.aNNNN extension, where NNNN is the disturbance record number) are copied from the device to the USB flash drive to the \EKRA\configuration_name*\Oscill_YYYYMMDD_hhmmss folder, where YYYYMMDD is the save date, hhmmss is the save time.

8.1.9.3 Software update (menu item **USB drive** → **Updating**)

When entering the menu, a security password is requested, enter a combination of symbols, which is a password, and press the "↵" ("ENTER") button.

The **Updating** menu allows you to update:

- device configuration;
- device program.

New configuration files, programs for updating – files "core.arh" and "sh.rtb" should be located in the "update" folder of the USB flash drive.

Setting/resetting the mark for updating the configuration and software is carried out with the "↵" ("ENTER") button.

To update, press the "↵" ("ENTER") button on the **Update** item.

The menu also displays the current and new versions of the configuration and software.

8.1.9.4 State of memory of USB flash drive (menu item **USB drive** → **Memory state**)

The menu displays the amount of used and free space on the USB flash drive.

8.1.9.5 Formatting USB flash drive (menu item **USB drive** → **Format**)

The menu allows you to format the USB flash drive. To confirm the selected procedure, a formatting request will appear on the display of the device.

8.1.9.6 Save documentation (menu item **USB drive** → **Save documentation**)

The menu allows you to save device documentation to an external USB flash drive. This item is available only if there is already documentation inside the device.

8.1.9.7 Save the report on settings (menu item **USB drive** → **Save settings report**)

The menu allows saving the report on settings to an external USB flash drive.

8.2 Updating and restoring the software of the ED2 series device

8.2.1 Function

During the operation of the device, situations may arise during which it is necessary to update or restore the system software or the configuration file of the device. Such situations include the occurrence of a software failure or the installation of a newer software version.

The system software in ED2 series devices can be updated in two ways – using the Smart Monitor software or using a USB flash drive. Working with the Smart Monitor software is described in the "EKRA SMS-SP software package" document. This document describes how to update the configuration file and system software using a USB flash drive.

The system software recovery is necessary if the changes made by the user during the operation of the device led to a failure or loss of the device's performance.

8.2.2 Update via USB flash drive

8.2.2.1 Requirements to USB flash drive

To update the configuration or system software, you need a USB flash drive with the following specifications:

- 1) FAT32 or FAT file system format;
- 2) drive capacity no more than 64 GB;
- 3) files of new configuration, software for updating – "configuration.arh", "core.arh", "sh.rtb"

files should be located in the "Update" folder of the USB flash drive.

The **USB drive** menu item is available only when a USB flash drive is connected to the front panel of the device to the USB connector.

8.2.2.2 Configuration and system software update process

When entering the **USB drive** menu, the front panel of the device asks for an access password. It is necessary to enter the password, taking into account the options of the rights of a particular user, and press the "↵" ("ENTER") button.

The **Updating** menu allows you to update:

- device configuration;

– device software.

Setting/resetting the mark for updating the configuration and software is carried out with the "↵" ("ENTER") button.

To update, press the "↵" ("ENTER") button on the **Update** item.

The menu also displays the current and new versions of the configuration and software.

8.2.2.2.1 To update the software, enter the item **USB drive** → **Updating** in the main menu, after which user authorization is required (see figure 93).

```
\User authorization
(Esc - view mode,
Left - delete symbol)
Enter password:
****

Active group: Settings group 1
13.02.2022 16:02:57
```

Figure 93 – User authorization

8.2.2.2.2 To update software and/or configuration, using "↵" ("ENTER") button, select the corresponding item and press **[Update]** (see figure 94).

```
\Updating
Actual configuration: 4.5.0.3 1.96.0
New config: 4.5.0.3 1.96.0
[+] Marking for configuration update

Actual program      :7.1.0.3.0
New program         :7.1.0.3.0
[+] Making for configuration update

[Update]

Active group: Settings group 1
13.02.2022 16:02:57
```

Figure 94 – Software and configuration update

8.2.2.2.3 If during the update the "**New config. doesn't correspond to actual SW**" error message appears (see figure 95, select the configuration version corresponding to the current software).

```

\Updating
Actual configuration: 4.5.0.3 1.96.0
New config: 4.5.2.3 2.96.0
[+]Marking for configuration update
New config. doesn't correspond to actual SW

Actual program      :7.1.0.3.0
New program         :7.1.0.3.0
[]Marking for configuration update

[Update]

Active group: Settings group 1
13.02.2022 16:02:57

```

Figure 95 – Software does not correspond to configuration

8.2.2.2.4 If during the update the “New SW doesn’t correspond to actual config.” error message appears (see figure 96), select the software corresponding to the current configuration version.

```

\Updating
Actual configuration: 4.5.0.3 1.96.0
New config: 4.5.0.3 1.96.1
[]Marking for configuration update

Actual program      :7.1.0.3.0
New program         :7.1.0.1.385
[+]Marking for configuration update
New SW doesn't correspond to actual config.

[Update]

Active group: Settings group 1
13.02.2022 16:02:57

```

Figure 96 – Software doesn’t correspond to configuration

8.2.2.2.5 If the new software version does not correspond to the new configuration version, select the software and configuration with the versions corresponding to each other (see figure 97).

```

\Updating
Actual configuration: 4.5.0.3 1.96.0
New config: 4.5.0.3 1.96.0

Updated at 09:01:38 09.03.2022

Actual program      :7.1.0.3.0
New program         :7.1.0.3.0

Updated at 09:01:45 09.03.2022

[Reset requiered to apply settings!]

Active group: Settings group 1
13.02.2022 16:02:57

```

Figure 97 – Software version corresponds to the configuration version

Note – The compatibility of the configuration and the software is checked as follows:

- if there is only a mark to update the configuration, then the compatibility of the new configuration with the current one is checked;

- if there is only a mark to update the software, then the compatibility of the current configuration with the new software is checked;

- if there are both marks, then the compatibility of the new software and the new configuration is checked.

8.2.3 "Software recovery" mode

8.2.3.1 The "Software recovery" mode is intended for restoring the internal software and configuration of the device.

The "Software recovery" mode is loaded automatically when a critical error occurs, which makes it impossible to start the system software of the device for two times in a row. Critical errors include:

- error of start parameters;
- error checking the integrity of configuration;
- error checking the integrity of system software;
- error checking the integrity of access rights file;
- error of configuration file.

Also, the user can independently switch the device to this mode via main menu of the device (**Service menu** → **Switch to software recovery mode**).

8.2.4 Communication parameters in the "Software recovery" mode:

- a) network address of device.....1;
- b) communication protocol via RS-485-1, RS-485-2 ports.....ModBus RTU;
- c) communication protocol via Ethernet interface.....ModBus TCP;
- d) operation rate via RS-485 interface.....115,200 baud;
- e) IP address of the IED via Ethernet, located on:
 - 1) front panel of the device172.17.63.29;
 - 2) back panel of the device:
 - Ethernet 1.....172.16.63.29;
 - Ethernet 2.....172.18.63.29;
 - 3) subnet mask255.255.0.0;
 - 4) gateway127.0.0.1.

8.3 Return to previous version of software via device menu

8.3.1 To switch the device to the "Software recovery" mode, do the following:

- in the main menu of the device, select the item **Service menu** → **Switch to recovery mode**;

- enter the password for user authorization and press the "↵" ("ENTER") button, an information message will appear about switching of the device to the "Software recovery" mode: "to switch to the recovery mode, restart the device in the current window";

- restart the device in the current window.

When the device is loaded into the "Recovery mode" mode, its display will show the main menu given in figure 98.

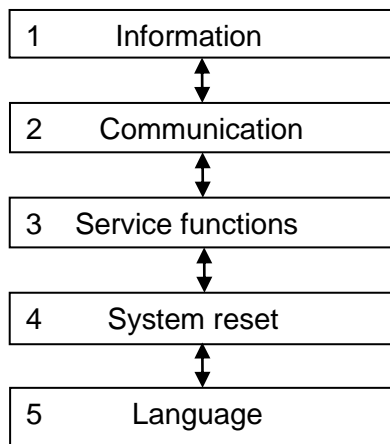

Figure 98 – Menu structure of the "Software recovery" mode

Returning to the previous/factory version of the software/configuration of the device can be done using the menu items:

- Service functions – by going to the factory version of the configuration and software;
- USB drive (see 8.3.3).

8.3.2 When switching to the **Service functions** menu item, the display of the device shows the menu given in figure 99.

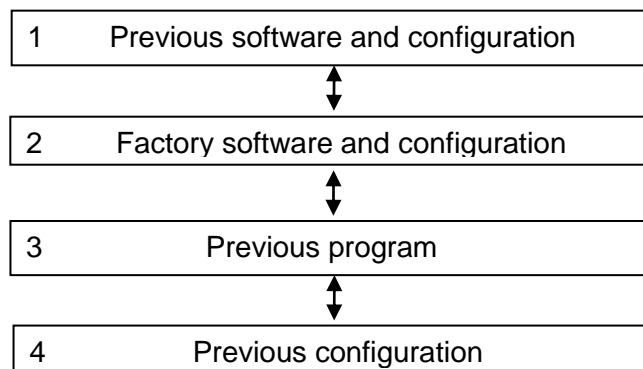

Figure 99 – Menu structure of the "Service functions" mode

Returning to the previous/factory version of the software/configuration is carried out by selecting the corresponding menu item.

Access to the item is allowed only after entering the password. Using the buttons it is necessary to type a set of symbols, which is a password, and press the "↵" ("ENTER") button. If the password is correct, the return process starts. If the password is found to be incorrect, the "Incorrect password" message will appear on the screen and you will be prompted to enter the password again.

In the window that appears, to return to the previous/factory version of the software/configuration, press the [Restore] button, to cancel – the [Cancel] button.

Upon successful completion of the return process, the device displays the "Operation completed successfully" message. If errors are detected while attempting to return, the following message will appear on the screen: "File to recover not found. An error occurred while performing the operation". The cause of the error may be an incompatibility of the configuration and software of the device.

8.3.3 When the USB flash drive is connected in the "Recovery" mode, the display of the device shows the menu given in figure 100.

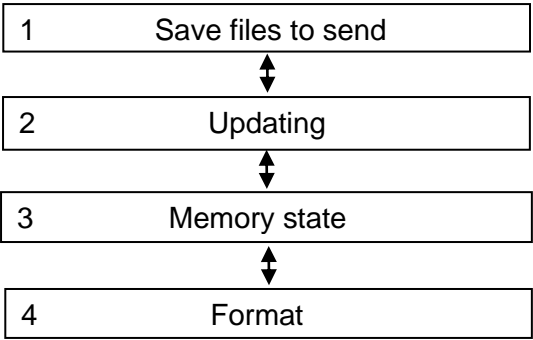

Figure 100 – Menu structure of the "USB drive" mode

Return to the previous/factory version of the software/configuration is carried out by selecting the Update menu item.

The recovery mode can only be exited by restarting the device.

9 Diagnostic functions

9.1 Self-diagnostic

The required level of reliability of the device operation is achieved by continuous self-diagnostic of the device with an action on the alarm in case of a failure. The self-diagnostic function continuously diagnoses the software functions of the device and hardware components.

Self-diagnostic includes checking the main hardware nodes and all software elements. Self-diagnostic does not cover binary inputs, contacts of output relays, analog inputs of the device.

The detected failure are displayed in the event log, on the device display, in the Smart Monitor software, in the event recorder of the device and in the disturbance recorder (not all device failure are available for disturbance recording).

The self-diagnostic function covers the following items:

a) hardware:

1) modules of analog inputs, modules of binary inputs, modules of binary outputs (the module itself and relay coils), combined module (the module itself and relay coils), power supply module;

2) logic module and its components (memory card, RAM, ROM, FP, CP);

b) software – communication protocols, time synchronization protocols, disturbance recorder, event recorder, parameter application functions and other device functions.

Data on limitations of the self-diagnostic function:

– the file of event log consists of 2 files that are rewritten in a circle when the size reaches at least 500 KB.

9.2 Diagnostic of device operation using the human-machine interface (HMI)

During device operation, Errors may occur that are detected by the self-diagnostic system of the device. The **Diagnostic** menu displays information about the state of modules, information about the state of communication ports, and information about the general state of the device. This menu includes the following submenus:

- state of modules;
- state of communication;
- IED state;
- synchronization.

9.2.1 State of modules (menu item **Diagnostic** → **State of modules**)

The **State of modules** menu displays the state of the modules ("OK", "Faulty" and "Warning") (see figure 101. The occurrence of the "Warning" signal means that a non-critical (more often information) error of device modules has occurred. The appearance of the "Faulty" signal means that a critical failure of the module has occurred. The "OK" signal means that everything is ok with this module.

For the logic module, the details of failure causes are available. Viewing the details of failure causes is carried out with the "↵" ("ENTER") button (see figure 102). Pressing it again will return the state of modules.

```

\State of modules
Name      Type      State
A1-E1    L2571    Warning
A1-E2    PU1602   Warning
A1-E3    R1630    OK
A1-E4    R1630    OK
A1-E5    R1630    OK
A1-E10   D2807    OK
A1-E11   D2976    OK
A1-E12   D3032    OK
A1-E9    EI2582   OK
A1-E8    EI2582   OK
A1-E7    EI2582   OK
Active group: Settings group 1
13.02.2022 16:02:57

```

Figure 101 – General view of the **Diagnostic** menu

```

\State of modules
N          Name
1          W "Failure of PPS"

Active group: Settings group 1
13.02.2022 16:02:57

```

Figure 102 – Viewing the details of failure causes

Additional information about block errors is shown by pressing the "Fn + 7 + 9" buttons in the "State of modules" menu item, as shown in figure 103.

```

\State of modules
Name      Type      State   CRC   CodeReset
A1-A-E1   L2571    OK      ----
A1-A-E2   PU1602   0x0000  0     0     0
A1-A-E3   R1630    0x0000  0     0     0
A1-A-E4   R1630    0x0000  0     0     0
A1-A-E5   R1630    0x0000  0     0     0
A1-A-E10  D2807    0x0000  0     0     0
A1-A-E11  D2976    0x0000  0     0     0
A1-A-E12  D3032    0x0000  0     0     0
A1-A-E9   EI2582   0x0000  0     0     0
A1-A-E8   EI2582   0x0000  0     0     0
A1-A-E7   EI2582   0x0000  0     0     0
Active group: Settings group 1
13.02.2022 16:02:57

```

Figure 103 – General view of the **State of modules** menu (detailed information)

9.2.2 State of communication (menu item **Diagnostic** → **State of communication**)

The **State of communication** menu displays quantitative parameters (see table 68) of the selected communication interface (see figure 104).

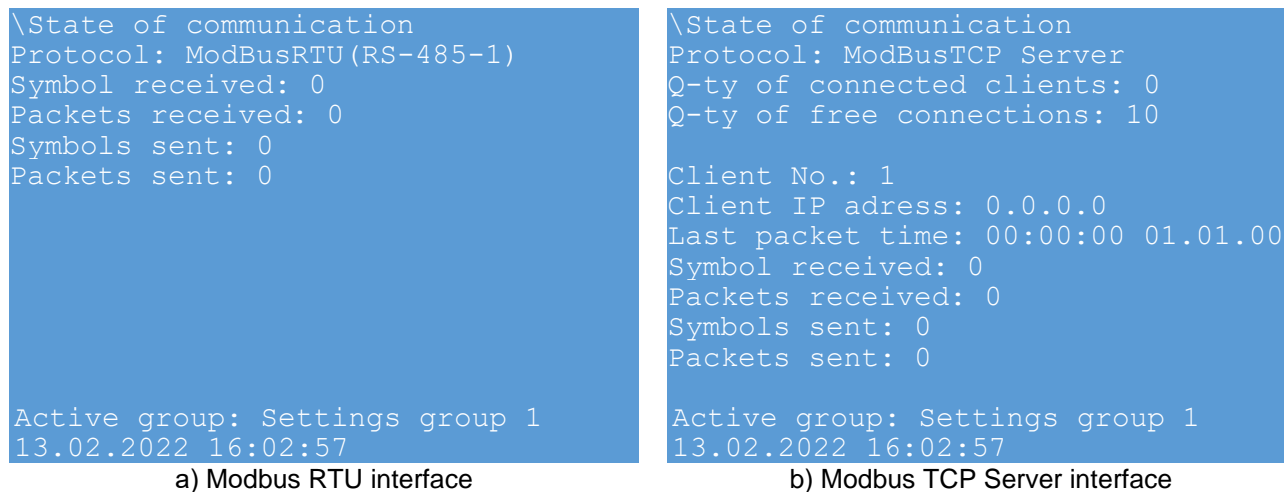

Figure 104 – Examples of displaying the **Network interface** menu

The communication interface is selected using the "▶", "◀" buttons.

Table 68 – State of communication interfaces

Parameter	Interface	Description
Symbol received	COM1, COM2, USB, Modbus RTU, Modbus TCP Server, IEC103 Slave	Quantity of received symbol
Symbols sent		Quantity of sent symbols
Packets received	COM1, COM2, USB, SNTP, Modbus RTU, Modbus TCP Server, 60870-5-104, IEC103 Slave	Quantity of received packets
Packets sent		Quantity of sent packets
Q-ty of connected clients	Modbus TCP Server	Quantity of connected clients
Q-ty of free connections		Quantity of free connections
Time diff, ms	SNTP	Time difference between client (device) and server (time source) in milliseconds
Request processing by server, ms		Time for request processing by server in milliseconds
Response wait by client, ms		Time waiting for response by client in milliseconds
Summer time feature		1 – summer, 0 – winter
Last sync time		Time of receiving last time synchronization command in hh:mm dd.mm.yy format
Latest received time		Last time received from server

Table continued on next page

Parameter	Interface	Description
Outgoing	61850 GOOSE	Signals, the current values of which will be transmitted to other devices
MAC		Broadcast MAC address to which GOOSE packets will be sent
Applet ID		Application identifier using a newsletter
Sent		Quantity of sent signals
stNum		Sequence number
Sending errors		Quantity of sending errors
Max. sending time		Maximum time for sending a GOOSE packet
Min. sending time		Minimum time for sending a GOOSE packet
Average sending time		Average time for sending a GOOSE packet
Max. quantity of MMS clients		61850 MMS
Client IP address	IP address of client	
Connect requests	Quantity of requests for connection	
Connect confirmations	Quantity of connection confirmations	
Connect errors	Quantity of connection errors	
MMS packets received	Quantity of MMS packets received	
MMS packets sent	Quantity of MMS packets sent	
Receiving/processing errors	Quantity of receiving/processing errors	
Preparation/sending errors	Quantity of preparation/sending errors	
Enabled	PRP	Protocol is enabled

9.2.3 State of IED (menu item **Diagnostic** → **State of IED**)

The **State of IED** menu displays general information about the device state (see figure 105):

a) **state of IED** – general state of the device. It can be in one of the following states presented in table 67 see section 8.1.8;

b) **Failure** – type of failure of the device. There are two types of failure:

1) An **Emergency** failure means that the device is disabled. This state is confirmed by glowing of the **Error** LED and lack of glowing of the **Ready** LED on the front panel of the device. In the event of an emergency failure, the normally closed contacts of the output relay located on the power supply module of the device are closed. The location of contacts of output relays for each specific module is indicated in Section 4 "General information about device design";

2) A **Warning** failure indicates a minor failure that will not disable the device. However, when organizing an exchange of information between devices using the IEC 61850 protocol, the occurrence of such a error can be critical. This condition is confirmed by glowing of the **Warning** LED;

c) **Operation** indicates an actuation of the relay protection function acting on the **Emergency alarm (Yes or No)**. LED indication of actuation of the relay protection function can be latching or non-latching. If the LED indication is latching, then to reset the LED indication, use the binary input of the device "**Reset**" or the combination of buttons "**Fn + 0**" from any item in the menu of the device;

d) **emulation**. Mode of signal emulation:

1) **On**. The On state indicates that the device is in the mode of **emulation of logic** or **matrix inputs**. In **emulation mode**, the voltage is removed from output relays. Entering and exiting the **emulation mode** is carried out using the Smart Monitor software;

2) **Off**. The Off state indicates that the emulation mode is disabled.

```
\IED state
State of IED: Off
Failure: Warning
Operation: No
Emulation: Off

Active group: Settings group 1
13.02.2022 16:02:57
```

Figure 105 – Menu **State of IED**

9.2.3.1 Synchronization (menu item **Diagnostic** → **Synchronization**)

The Synchronization menu (see figure 106) displays the states of time synchronization protocols.

```
\Synchronization
Synchronization via PTP: [ ]
Error conf. Eth redundancy module:[ ]
Sync, time: -
Q-ty of sync. requests: 0
Q-ty of repeated requests: 0
Maximum repetitions per requests: 0

Active group: Settings group 1
13.02.2022 16:02:57
```

Figure 106 – Menu **Synchronization**

The state of synchronization is described in table 69.

Table 69 – State of synchronization

Parameter	Notes
Synchronizing via PTP	Synchronization via PTP is turned on/off
Error configuring Ethernet redundancy module	When an error is set, synchronization via PTP is not performed
Synchronization time	Last time read using the PTP synchronization protocol
Quantity of synchronization requests	Information for developers
Quantity of repeated requests	Information for developers
Maximum repetitions per request	Information for developers

10 Information security

To protect the interests of Customers, access to ED2 devices and software tools that allow working with them is protected by an authorization procedure.

Device user authorization is designed to prevent user's unauthorized actions to control switching equipment, change of modes and settings of the device.

The device performs its functions based on the real-time operating system – ON TIME RTOS-32. To identify and authenticate the subject of access, information about users (user name, password), who are assigned rights (roles) in accordance with the subject's job responsibilities, is entered into the device.

Authorization occurs both when working with the HMI and when working with the Smart Monitor software.

User authorization in the device using the HMI is carried out using a password (figure 107).

```
\User authorization
(Esc - viewing mode,
Left - delete symbol)
Enter password:
****

Active group: Settings group 1
13.02.2022 16:02:57
```

Figure 107 – User authorization via device HMI

User authorization via Smart Monitor software is carried out with username and password (figure 108).

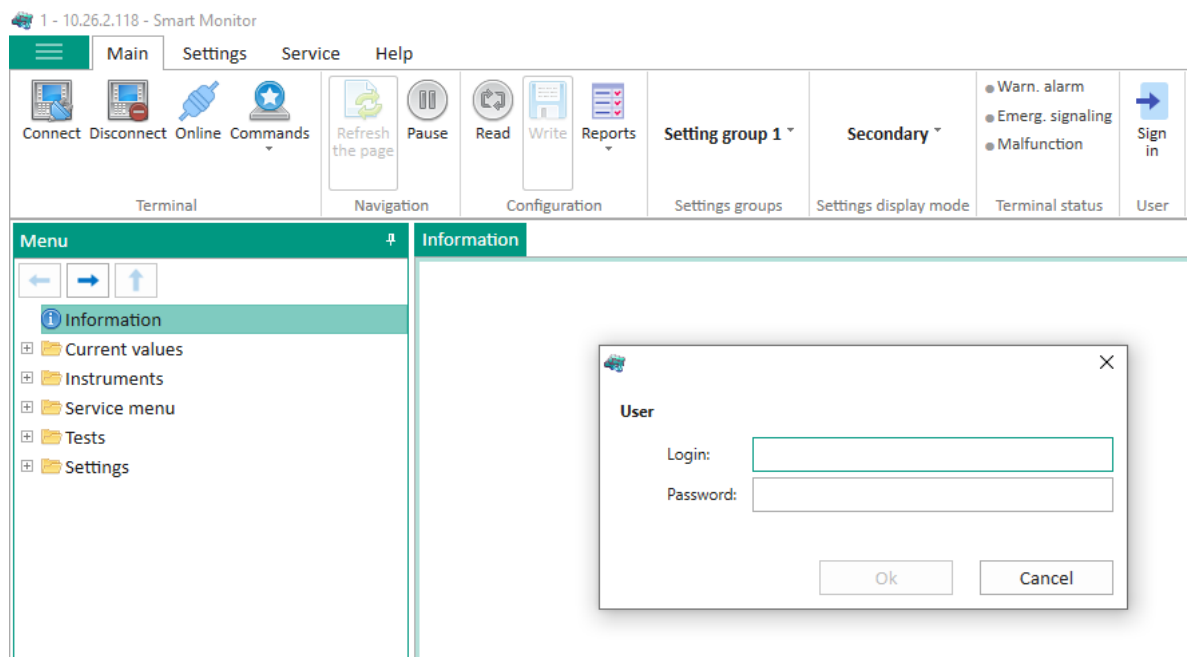

Figure 108 – User authorization via Smart Monitor software

If an incorrect password is entered, the user can only view the device parameters.

After entering the wrong password five times in a row, the possibility of re-authorization is blocked for a time fixed by the manufacturer, and the message "User authentication is blocked, only viewing is available" appears on the device display. At the first blocking, the device becomes blocked for 6 minutes, in subsequent cases this time increases up to 30 minutes.

User's actions to change parameters and control, protected by a password, are registered in the device memory with recording of the user's name and group, date and time of action.

If there is no activity for the time specified by the administrator, the device is logged out of the user account. The time is set in the Smart Monitor software in the menu item of the project "tree" **Settings** → **System parameters** → **Parameters of IED** → **"Access timeout"** parameter. To apply the changes, the settings must be written to the device.

Setting and changing administration parameters is carried out using the Smart Monitor software, control panel **User** → **Administration of users**). Applying changed or new parameters does not require a device restart.

 **NOTICE**

Before using the device, you must change the default passwords. In order to divide responsibilities among personnel, it is necessary to assign users and groups in accordance with the required conditions. Operation of the device by users with full access rights ("admin", password "0100", group "g administrator") may lead to unauthorized actions of the personnel.

There are different groups of users who can work with different functions of the device and different sets of software tools. Preset user groups are given in table 70.



NOTICE

When writing data to the device from the Smart Monitor software, make sure that the user in the system has the necessary access rights.

Table 70 – Preset user groups and their rights to change parameters

Name	Administrator	Protection and control engineer	Operator
Parameters of analog inputs	+	+	-
Enabling/disabling parameters of binary inputs	+	+	-
Parameters of measuring elements	+	+	-
Parameters of matrix	+	+	-
Parameters of logic	+	+	-
Parameters of disturbance recorder	+	+	+
Parameters of event recorder	+	+	+
Parameters of switching device remaining life	+	+	-
Save settings and software, configuration updates	+	+	-
Parameters of communication	+	+	-
Parameters of smoothing factors for calculated values	+	+	-
Parameters of analog modules	+	+	-
Parameters of modules of binary inputs	+	+	-
Parameters of modules	+	+	-
Check of modules	+	-	-
Parameters of synchronization	+	+	-
Parameters of menu language	+	+	+
System time change	+	+	-
Brightness of LEDs	+	+	+
Brightness of backlight	+	+	+
LEDs test	+	+	-
Test of output relays	+	+	-
Automatic testing	+	+	-
GOOSE test	+	+	-
SV test	+	+	-

Table continued on next page

Name	Administrator	Protection and control engineer	Operator
Mimic diagram, control	+	+	+
Control via 61850	+	+	-
Menu of USB drive	+	+	+
Settings of calculated values	+	+	-
Parameters of receiver	+	-	-
Parameters of transmitter	+	-	-
Control, ES, mimic diagram	+	+	+
Record by FTP	+	-	-
Access to reading of IS event log	+	-	-
User administration	+	-	-
Setting of IS parameters	+	-	-
Reset to default settings	+	-	-
Switching IED to service mode	+	-	-
Alarm reset via Modbus protocol	+	+	+
Reading of disturbance records files	+	+	+
Control of IED state	+	-	-



NOTICE

It is possible to create, delete and edit device users only using the Smart Monitor software. The user can only log in or log out on the HMI.



NOTICE

Username should only use characters A – Z, a – z, 0 – 9, "_".
Maximum quantity of user characters: 16.



NOTICE

Password should only use characters 0 – 9.
Quantity of password characters: 4 – 16.

Users and user groups of the device, as well as their rights can be created, deleted and edited using the Smart Monitor software in the "Administration of users" tab (see document "EKRASMS-SP software package").

11 Assembly

11.1 Safety measures

11.1.1 When preparing for assembly, assembly work and commissioning of devices, it is necessary to be guided by local regulations on electrical safety and rules for the safe performance of work, as well as the requirements of this document.

11.1.2 Specially trained individuals who have studied the documentation for the device and have the necessary qualification to perform these works are allowed to work with the devices.



WARNING

Compliance with this requirement is necessary to prevent electric shock of the operating personnel and the occurrence of other dangerous situations.

11.1.3 Work on the connectors of the device should be carried out in a de-energized state and the measures taken to prevent personnel injury from electric shock, as well as to preserve the device from damage.



WARNING

Compliance with this requirement is necessary to prevent electric shock to operating personnel.

11.1.4 Devices must be properly earthed before energizing and during operation.



WARNING

This requirement for earthing the device is necessary to prevent electric shock to operating personnel.

11.1.5 The design of devices is fireproof in accordance with the requirements of IEC 60255-27, it is not a source of ignition.

11.2 Equipment and documentation required for assembly

For successful assembly work, it is necessary to familiarize yourself with the documentation for the assembly of the product (including this document, the operation manual for the version of the device).

Note – devices that have passed unpacking and incoming control are subject to installation.

Prepare tools and accessories for preparing the device for assembly, assembly and commissioning of the device in accordance with table 71.

Table 71 – Tools needed for unpacking and assembly

Name	Specifications	Type of works
Crimping tool	–	Crimping the wire into the ferrule
Screwdriver (flat)	Slot width no more than 3 mm	Compression of the spring to insert the conductor into the terminal
Screwdriver (Phillips)	–	–
Wrench	Wrench size for assembly – 10	Tightening the nut
Screwdriver machine	Slot width 4 mm	Tightening the screw

11.3 General

11.3.1 The device should be installed at the place of operation on the vertical plane of cabinets or other structures with a permissible deviation from the vertical position of the supporting surface of the device up to 5° in any direction.

11.3.2 The assembly of the device should be carried out in a de-energized state of the structure where the device is mounted. If it is necessary to carry out checks with the voltage applied, additional protective measures must be used to prevent the operating personnel from being injured by electric shock.



WARNING

Compliance with this requirement is necessary to prevent electric shock of the operating personnel and the occurrence of other dangerous situations.

11.3.3 The location of the terminal blocks and connectors of the device is given in the operation manual for the specific version of the device.

11.3.4 The device must be electrically connected to other adjacent devices using cables with a cross section of at least 0.75 mm² / AWG 19.

11.3.5 The connection of the device should be carried out in accordance with the instructions in the operation manual for the specific version of the device.

11.3.6 The back plate of the device is provided with earthing conductor screws, which should only be used for connection to the earthing loop.



CAUTION

Compliance with earthing requirements of the device is mandatory!

11.4 Installation of device



CAUTION

The device must be installed by two people!

Options of device installation:

- a) flush-mounting;
- b) flush-mounting with a decrease in the installation depth by 50 mm;
- c) surface-mounting.

Panel layouts for device installation are given in Subsection 9.4. Below are examples of installation of the ED2 devices of 1/3 19" design; installation of devices of other versions is carried out in the same way.

11.4.1 Flush-mounting

11.4.1.1 The device is **flush-mounted** in a rectangular cut-out of the support panel (see Figure 109).

11.4.1.2 The list of fasteners for the device is given in table 72.

Table 72 – List of fasteners for recessed installation of the device

Name	Quantity, pcs
Bolt M6-6gx25.58.C.019	4
Nut M6-6H.05.C.019	4
Washer C.6x1.0.01.10 kp 019	8

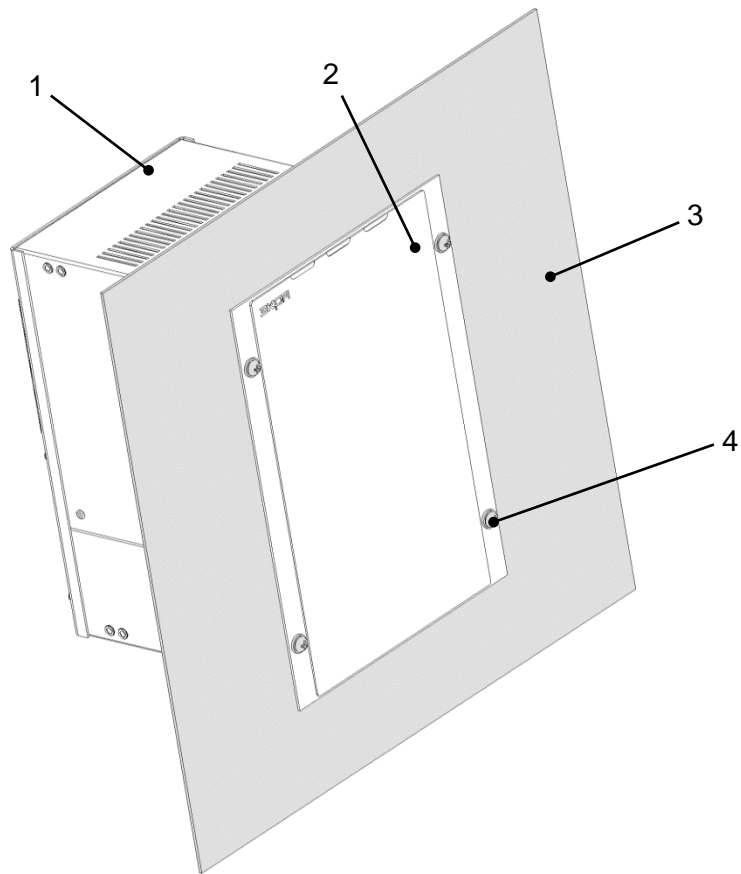

1 – ED2;

2 – front panel of the device;

3 – support (assembly) panel;

4 – device fastening bolt

Figure 109 – Installation of the ED2 devices of $\frac{1}{3}$ 19" design (flush-mounting)

11.4.1.3 Insert the device into the cut-out of the support panel. Slide the device into the cut-out until the front panel reaches the support panel. Do not let go of the device without fixing it with at least one bolt.

11.4.1.4 Place a washer under the bolt head, thread the bolt into the fastening hole. Carry out alternately for all four bolts.

11.4.1.5 Tighten the bolt with a nut, placing a washer. Carry out alternately for all four bolts. The operation should be performed in several stages, alternately tightening all the nuts to the end.

11.4.2 Flush-mounting with a decrease in the installation depth by 50 mm (see figure 110)

11.4.2.1 The device is flush-mounted in a rectangular cut-out of the support panel extending 50 mm from the support panel. The list of fasteners for the device is given in table 73.

Table 73 – List of fasteners for installing the device directly to a vertical surface with reduced installation depth

Name	Quantity, pcs
Bolt M6-6gx70.58.016	4
Nut M6-6H.5.016	4
Washer 6 65G 016	4
Washer C.6.01.10kp.016	8
Stop EKRA.745432.001	2

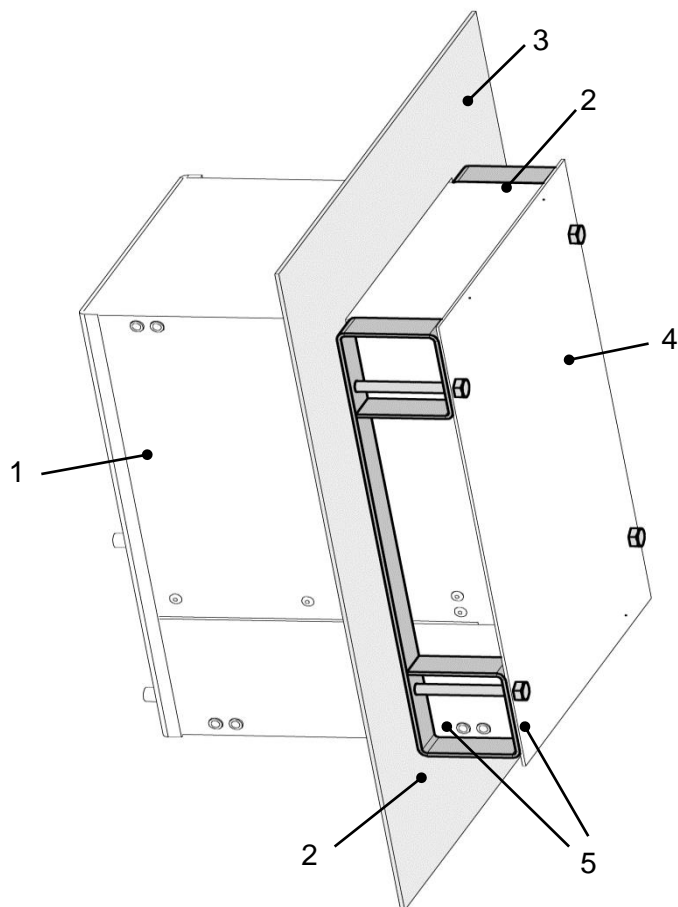

1 – ED2;

2 – stop;

3 – support (assembly) panel;

4 – front panel of the device;

5 – device fastening bolt

Figure 110 – Installation of the ED2 devices of 1/3 19" design
(flush-mounting with a decrease in the installation depth by 50 mm)

11.4.2.2 Insert the device into the cut-out of the support panel. Slide the device into the cut-out until the distance between the front panel of the device and the support panel is approx. 50 mm. Do not let go of the device without fixing it with at least one bolt.

11.4.2.3 Insert a stop between the front panel of the device and the support panel, place a washer under the head of the bolt and tighten the bolt. The stop is secured with two bolts. Run alternately for two stops.

11.4.2.4 Tighten the bolt with a nut, placing a washer. Carry out alternately for all four bolts. The operation should be performed in several stages, alternately tightening all the nuts to the end.

11.4.3 Surface-mounting (see figure 111)

11.4.3.1 ED2 devices of 1/3 19" design are installed using specialized fasteners (shells and plates). The list of fasteners for the device is given in table 74.

Table 74 – List of fasteners for the wall mounting of the ED2 devices of 1/3 19" design

Position (in figure 111)	Name	Quantity, pcs
1	Shell EKRA.301582.001	2
2	Plate EKRA.301714.007	2
4	Screw A2.M4-6gx14	28
5	Screw A2.M6-6gx14	4
6	Washer 4 65G 016	16
7	Washer 6 65G 016	4
8	Washer A4.016	16
9	Washer A6.016	4
11	Screw M6x16	4

11.4.3.2 Place two plates on the shell and tighten the screws (item 4).

11.4.3.3 Install the device in the lower shell.



CAUTION

The front panel of the device must be on the side of the marking on the shell!

11.4.3.4 Thread the screws (item 4) with washers (item 6 and item 8). Do not tighten.

11.4.3.5 Install the top shell into the plates. Thread the screws (item 4) with washers (item 6 and item 8). Tighten all screw connections.

11.4.3.6 Tighten the screws (item 11) to secure the front panel of the device to the shells.

11.4.3.7 Tighten the screws (item 5) with washers (item 7 and item 9) to secure the shells to the assembly panel.

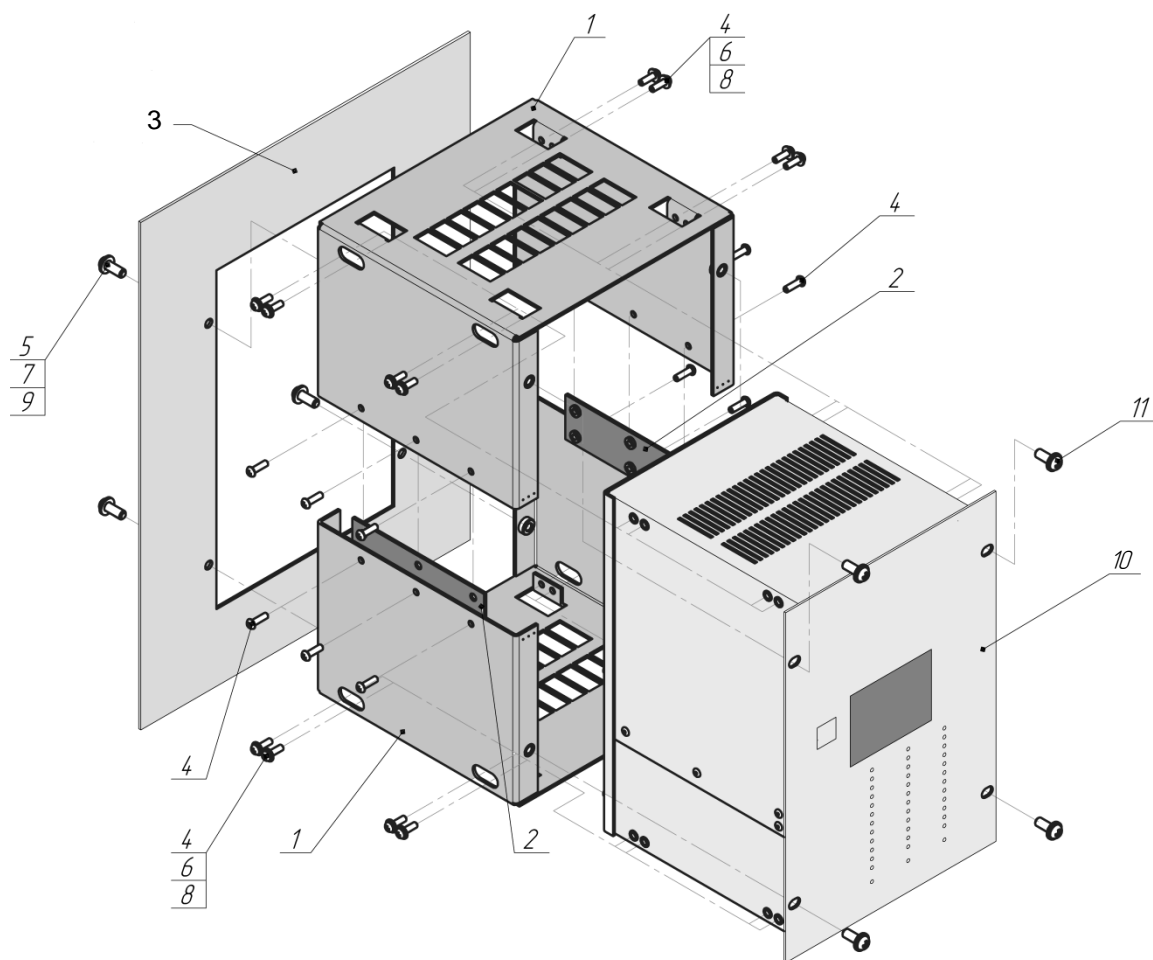

- | | |
|-------------------------------|---------------------------------|
| 1 – shell; | 4, 5 – screw; |
| 2 – plate; | 6, 7, 8, 9 – washer; |
| 3 – support (assembly) panel; | 10 – front panel of the device; |
| | 11 – device fastening screws |

Figure 111 – Surface-mounting of the ED2 devices of 1/3 19" design

It can be used for other versions, but the device will be without an indication module or with a remote indication module and will be installed without a specialized fastening (wall mounting with one-sided service).

11.4.4 Depending on the place of installation, the weight of the device, additional fastening can be used, for example, brackets. Brackets are attached to the sides of the device.

The design of the device also provides additional fastening points, as shown in figure 112).

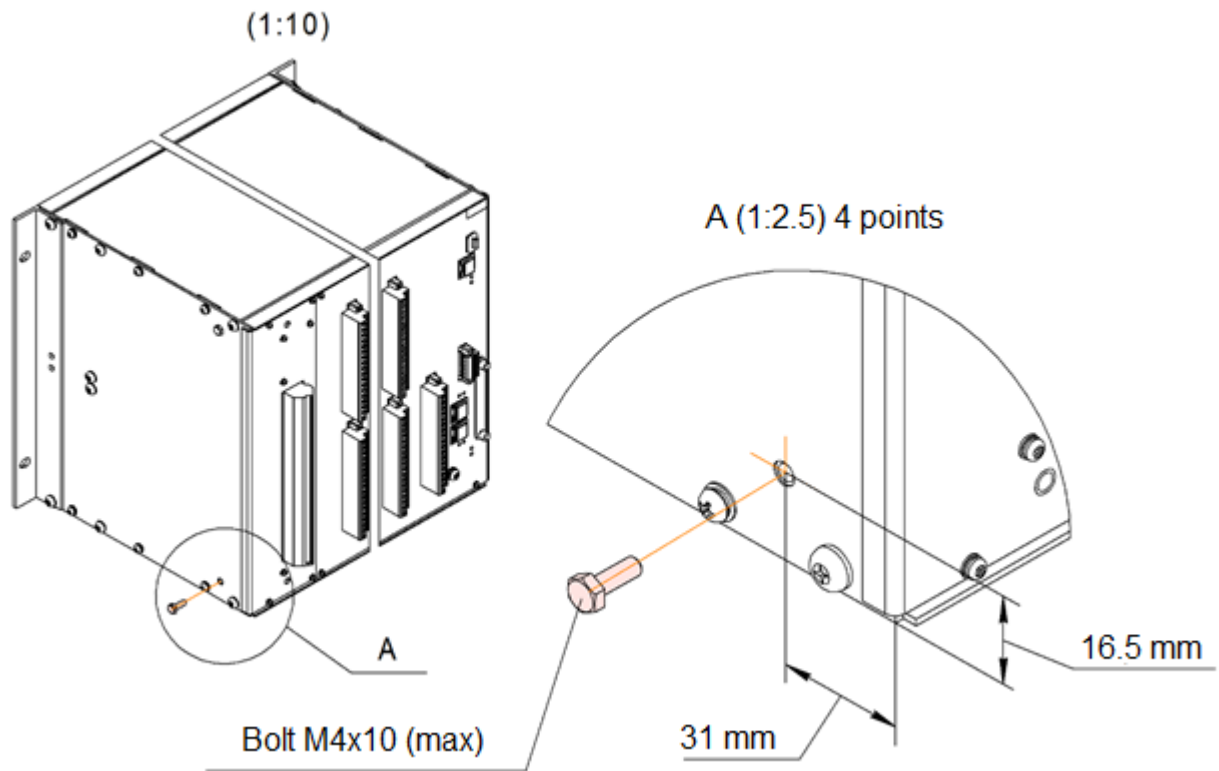

Figure 112 – Additional fastening points for the ED2 devices except of 1/3 19" design

11.5 Installation dimensions on site

11.5.1 Panel layout for installation of the ED2 devices is shown in figure 113.

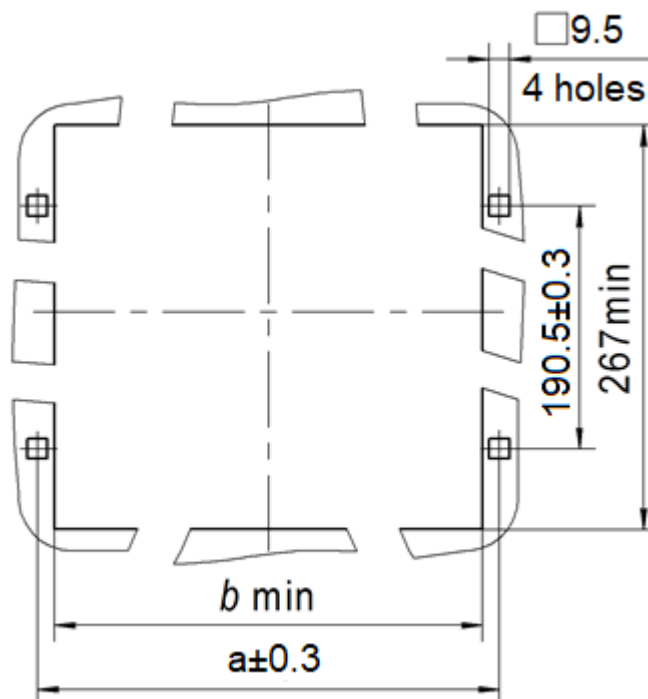

Figure 113 – Panel layout for installation of ED2 series devices
(except for ED2 devices of 1/3 19" design)

The installation dimensions of devices are given in table 75.

Table 75 – Installation dimensions of devices

Device type	a, mm	b min, mm
devices of ½ 19" design	252	236
devices of ¾ 19" design	358	342
devices of 19" design	465	449

11.5.2 The layout of the panel for installation of the ED2 devices of ⅓ 19" design is given in figure 114.

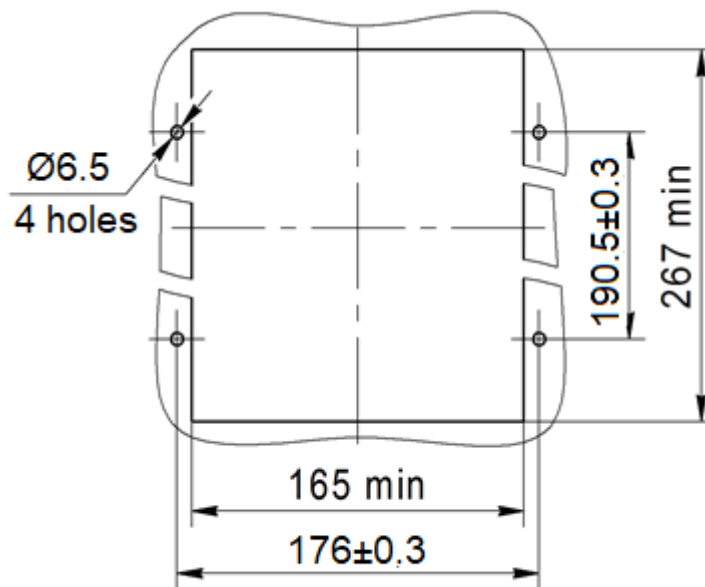

Figure 114 – Panel layout for installation of the ED2 devices of ⅓ 19" design

11.6 Installation of ED2 devices of 1/3 19" design with reduced installation depth

11.6.1 Installation of the ED2 devices of 1/3 19" design with reduced installation depth is given in figure 115.

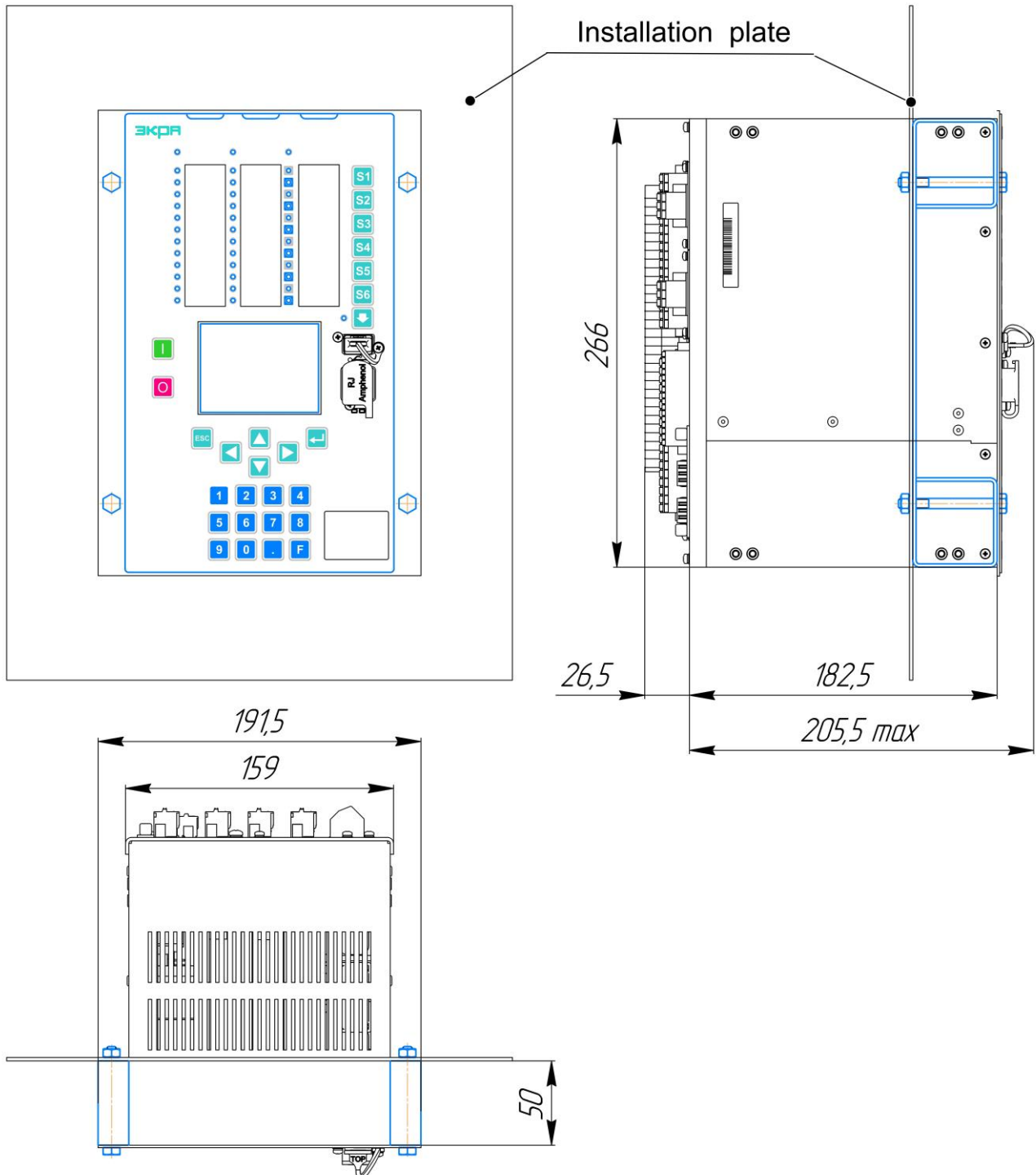

Figure 115 – Installation of the ED2 devices of 1/3 19" design reduced installation depth

11.7 Making electrical connections of device



CAUTION

Before performing any work on this equipment, the user must be familiar with the safety information and parameters indicated on the nameplate.



CAUTION

Before carrying out any work on this equipment, the user must be familiar with this operation manual.

11.7.1 Device connectors

The connectors used in the device are shown in the table 23.

The number and purpose of connectors depends on the device version and is determined by a specific project.

11.7.2 Technology of conductor connection



NOTE

All input conductors must be wired.

11.7.2.1 The terminal block allows conductors up to 4.0 mm² to be connected directly without tools (push-in technology).

Cable ferrule for use in current circuits:

– ferrule with a diameter of 2.5 mm² and a length of 12 mm for a wire with a cross section of 2.5 mm².

Cable ferrule for use in voltage circuits, binary inputs / outputs and device power circuits:

– ferrule with a diameter of 0.75 mm² and a length of 12 mm for a wire with a cross section of 0.75 mm².

11.7.2.2 Connection type – screw clamp with compression sleeve:

- insert the conductor(s) into the ferrule;
- insert the conductor(s) with a ferrule into the terminal;
- tighten the screw. The fastening screw should be tightened with a torque of 0.4 N·m.

11.7.2.3 Optical conductors must be connected with a bend radius of at least R = 50 mm.

11.7.3 Principle of marking terminals

11.7.3.1 All terminals and connectors for connection to the device are located on the back panel. Additionally, on the front panel of the device there is a connector for connecting the device to a PC (Ethernet) and a USB port for connecting a USB flash drive.

11.7.3.2 Terminal block and connectors are marked in Xn format, where n is an integer.

11.7.3.3 For example, in figure 7: X21 – RS-485 interface connector.

11.7.4 Procedure for making electrical connections of the device

11.7.4.1 Connect the protective earthing screw(s) located on the back of the module to the nearest earthing point (see figure 6). Use a copper wire with a cross section of at least 6 mm^2 with a ring ferrule.

Note – Depending on the version of the device, one screw with an M5 thread or two screws with an M4 thread are used.

11.7.4.2 Carry out the installation of wires to the female part of connectors of the device in accordance with the project.

11.7.4.3 Install the connectors of communication interfaces.

12 Commissioning instructions

12.1 General instructions

Before putting the device into operation required:

- prepare the necessary documentation for protection devices;
- prepare the necessary instruments, test equipment and tools and all the necessary device connection diagrams;
- check the condition of the installation, the reliability of the contact connections, the tightness of the bolted connections;
- check ground circuits, perform electrical insulation test;
- make sure that the hardware of the device is working correctly and that the settings are appropriate for the conditions of use of the product at this object. You can view the settings of the device under test using the Smart Monitor software or use the front panel interface of the device to do this;
- to check all functions, with the execution of the corresponding protocol for checking these functions (protocol of commissioning tests).

The device menu language can be changed by the user. If necessary, at the time of commissioning, you can select a different language for the device menu.



CAUTION

Before performing any work on this equipment, the user must be familiar with the safety information and parameters indicated on the nameplate.



CAUTION

Before performing any work on this equipment, the user must be familiar with this operation manual.



WARNING

During commissioning, it is necessary to short-circuit secondary windings of measuring current transformers to prevent electric shock.



WARNING

To exclude false actions of the device in external circuits, before carrying out commissioning work, it is necessary to disable the device.

The procedure of disabling the device is described in 12.4.

12.2 Device testing functions using the HMI and Smart Monitor software

The functions of testing the device using the front panel and Smart Monitor software are described in detail in 12.5.5 – 12.5.8, 12.6, 12.6.2.

12.3 Recommended equipment for commissioning

The list of recommended equipment for commissioning tests of devices is presented in table 76. The presented equipment can be replaced with a similar one, provided that its characteristics are not lower than the recommended ones.

Table 76 – List of recommended equipment for commissioning

Name	Recommended type of equipment	Main specifications
Digital multimeter	APPA-91	0.1 mV – 1000 V; Error $\pm (0.5 \% + 1 \text{ dgt})$; $- U$ 0.1 mV – 750 V; Error $\pm (1.3 \% + 4 \text{ dgt})$; $\sim U$ 0.1 μA – 20 A; Error $\pm (1.0 \% + 1 \text{ dgt})$; $- I$ Error $\pm (1.5 \% + 3 \text{ dgt})$; $\sim I$ 0.1 Ohm – 20 MOhm; Error $\pm (0.8 \% + 1 \text{ dgt})$
DC power supply source	GPR-30H10D	(0 – 1) A; Error $\pm (0.005 I_{\text{SET}}^{1}) + 0.02 \text{ A}$; (0 – 300) V; Error $\pm (0.005 U_{\text{SET}}^{2}) + 0.2 \text{ V}$
General-purpose voltage breakdown device	TOS 9201	up to 5 kV; Error $\pm (1.5 \% + 20 \text{ V})$
Insulation resistance measuring device	E6-24	10 kOhm – 9.99 GOhm; Error $\pm (2 - 20) \%$
Multifunctional measuring equipment	CMC 356	6 x $\sim (0 - 32) \text{ A}$; Error $\pm 0.15 \%$; 4 x $\sim (0 - 300) \text{ V}$; Error $\pm 0.08 \%$
<p>Note – It is allowed to use other measuring means and equipment, analogous by their technical and metrological characteristics and providing preset test modes.</p> <p>¹⁾ I_{SET} – set value of output current. ²⁾ U_{SET} – set value of output voltage.</p>		

12.4 Decommissioning

To exclude incorrect influences in external circuits, before carrying out commissioning work of the ED2 device, it is necessary to switch the device from the "ON" mode to the "OFF" mode. The device operation modes are described in more detail in table 47 of this manual.

ED2 devices are taken out of service using the Smart Monitor program or the device menu. To output using the device menu, go to the "Operating mode" item (see Figure 116a), log in and select the appropriate "Output" mode. Next, you need to confirm the transfer to the "Output" mode

by re-entering the password. Next, a [+] sign will be displayed next to the "Output" item (see Figure 116b) which will mean that the device has been successfully transferred to the "Output" mode.

To transfer the device to the output mode using the Smart Monitor program, see the document "EKRASMS-SP software package".

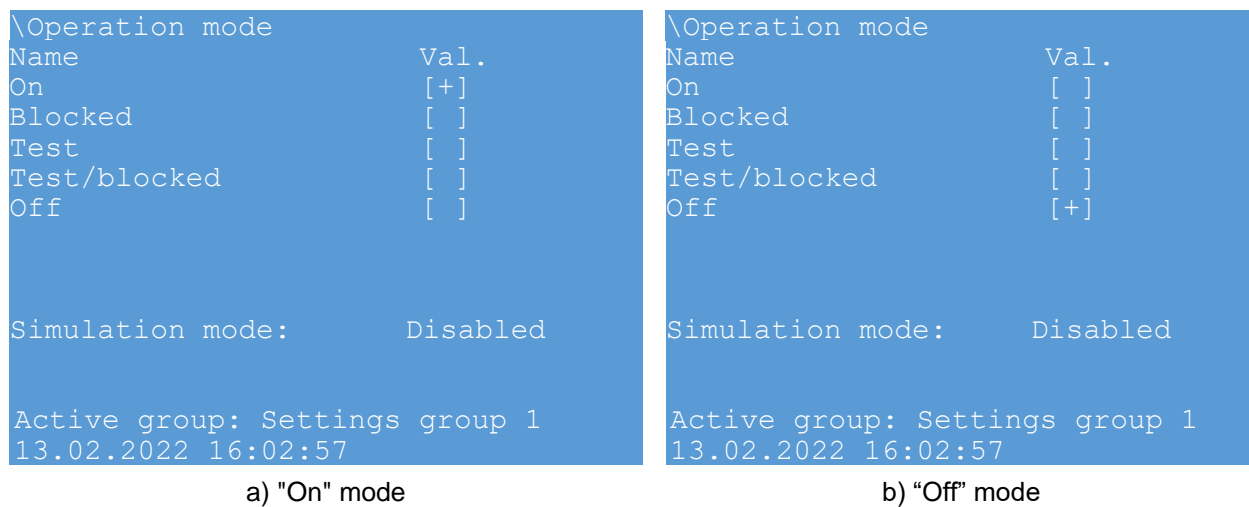

Figure 116 – Display of modes for the ED2 devices

12.5 Device check

12.5.1 Visual inspection, check for compliance with design documentation (DD) in accordance with the order sheet for the device



WARNING

Visual inspection and quality control of the assembly is carried out on a de-energized device!

The quality check of the assembly is carried out visually. The following is checked:

- compliance of the device with the documentation of manufacturer;
- assembly quality;
- absence of mechanical damage to protective, protective-decorative and special coatings of the device;
- no loose fasteners.

Checking the overall and installation dimensions of the device design is carried out using a special measuring tool that ensures the accuracy of measurements within the tolerances specified in the drawings.

12.5.2 Check of delivery for completeness

Completeness is checked by comparing the actual set of documents with the specification for the contract.

The standard delivery set includes the device, documentation from the list below, as well as a CD or USB flash drive with software and all information necessary for operation.

The following documentation is checked:

- safety information;
- device check report.

12.5.3 Check of presence and quality of marking

The presence and correctness of inscriptions (markings) is checked in accordance with the device order sheet. The marking must be clear and legible.

Quality control of marking is carried out in accordance with IEC 60255-27.

The following is checked: the presence and correctness of the marking on the information plate of the device and their compliance with the order sheet and the required functional purpose.

12.5.4 Device self-diagnostic

Self-diagnostic of the device (automatic check) is carried out continuously, therefore the preliminary check of the device operability consists in checking the absence of the red "Error" LED on the front panel of the device after 60 s after energizing.

12.5.5 Check of main functions of the device

The parameters of the event and disturbance recorder functions are checked using the application programs included in the software package EKRA SMS-SP supplied with the device.

The channel of serial communication is tested using the Smart Monitor software in accordance with the user's manual.

The indication of voltage, current and other values is checked using the display, the Smart Monitor software or by outputting information to external devices.

12.5.6 Check of binary inputs

The actuation of a binary input when the state of the receiving circuit changes to active is recorded in the **Binary inputs** menu of the Smart Monitor software (**Current values** → **Binary signals** → **Binary inputs**) or using the device display in the **Binary inputs** menu item (**Current values** → **States of inputs/outputs** → **Binary signals** → **Binary inputs**).

To check the actuation threshold, a constant current source with an adjustable output voltage with a maximum value of at least 0.9 of the rated voltage of binary input is used.

The supply voltage was gradually increased. The value of supplied voltage was recorded when at least one binary signal ($U_{act.min}$) appeared, the value of supplied voltage was also recorded when all binary inputs ($U_{act.max}$) actuated. Then the supply voltage was gradually decreased. The value of supplied voltage was recorded when at least one binary signal ($U_{res.max}$) was reset, and the value of supplied voltage was also recorded when all the binary inputs ($U_{res.min}$) were reset.

12.5.7 Check of output circuits

The actuation of output circuits is checked using the test mode in the Smart Monitor software menu item **Relay test (Tests** → **Relay testing**) or via the **Relay test** device menu (**Tests** → **Test of modules** → **Relay test**) commands were generated for actuation of the device relay. In

accordance with the circuit diagram, the closed state (for normally open relay contacts) and the open state (for normally closed relay contacts) of output circuits of the device were monitored at the terminals of the device using a multimeter.

12.5.8 Check of input analog circuits

Input circuits for receiving analog signals is checked by supplying symmetrical systems of currents and voltages of industrial frequency from the test module to each analog input.

The accuracy of measurement and recording of input signals of the device is checked by supplying input values of signals (currents, voltages) and comparing the readings of the reference device (ammeter, voltmeter) with the actual values on the display or control disturbance record displayed using the Waves software for analyzing disturbance records included in the Smart Monitor software.

12.5.9 Insulation resistance monitoring

The insulation resistance of the device is checked in a cold, de-energized state under normal climatic conditions in accordance with IEC 60255-27.

Insulation resistance is checked between groups of all independent circuits of the device, connected to a number of clamps, as well as between these circuits and metal non-current-carrying parts of the device. Insulation resistance is measured using a 500 V megohmmeter.

The insulation resistance is measured when the set value is reached.

The insulation resistance of independent circuits relative to the enclosure and between themselves was measured with a megohmmeter for a voltage of 500 V.

According to IEC 60255-27 the insulation resistance should be at least 100 MOhm.

12.5.10 Check of continuity of the protective earthing circuit

The continuity of the protective earthing circuit is checked by measuring the value of electrical resistance between the earthing bolt of the device and each earthed design element of the device. In this case, the resistance of all circuits according to IEC 60255-27 should not exceed 0.1 Ohm.

12.5.11 If necessary, the time delays of the device logic can be checked.

When checking the time delay DT for actuation, the time is measured from the moment the binary signal (the signal leading to actuation of the time delay) is applied until the contacts of the control relay are closed. When checking the time delay DT for reset, a binary signal was first issued, and then the time from the moment the binary signal was removed to the opening of the control relay contacts was measured.

When analyzing the test results, it should be taken into account that the measured value of time delay includes the actuation time of binary output of the test complex (approximately 10 ms), binary input of the device (standard value 15 ms), binary output of the device (approximately 10 ms), therefore, for DT elements measurement deviation from the setting within 45 ms is considered permissible.

12.5.12 Check of the PPS hardware time synchronization function

Synchronization pulses are applied to the synchronization input (PPS) of the device using a synchronization source with parameters that match the settings.

In the absence of external time synchronization pulses, the hardware time synchronization function generates an error about the failure of synchronization circuits. On the LED indication panel of the device, the "Warning" signal becomes active.

12.5.13 Check of specifications of device protections. General provisions

Check is carried out using an external source – a test device (hereinafter – "test device") at the recommended environmental parameters (see 4.10). The functions are checked in accordance with the operation manual for the specific version of the device. It describes in detail the principles of operation, as well as all the information necessary for checking a specific protection function or device automation.

When checking the value of protection actuation (reset), the increase (decrease) of the influencing input value to the value of actuation (reset) is carried out smoothly.

Light indicators on the front panel of the device or contacts of output relays of the device are used as an indicator of protection actuation.

The basic error is checked based on the settings specified by the customer (when providing the settings sheet), or based on standard settings. The evaluation of measurement results is carried out according to the arithmetic mean of three measurements.

12.6 Load current check

These checks must be performed only if there are no restrictions for supply of voltage to the protected facility, and other protection devices of the facility have already been adjusted and commissioned.



WARNING

When checking the operation of the device with operating current and voltage, it is necessary to strictly comply with all local requirements of regulatory documents on electrical safety.



WARNING

When checking the operation of the device with operating current and voltage, use approved personal protective equipment against electric shock.



WARNING

It is necessary to remove all test conductors and temporary jumpers, as well as restore all external connections removed during the commissioning checks.



WARNING

In case the conductors of external connections were disconnected, then check with the corresponding diagrams of external connections and circuit diagrams when restoring the connection!

12.6.1 Check of correct connection of current transformer circuits

It is necessary to measure secondary currents of current transformers for each input.

To confirm that the correct polarity and phase sequence of CTs connected to the device are observed, it is necessary to compare the measured phase angles of the currents with other devices installed on the site.

Make sure that the current in the neutral conductor of current transformer is negligible.

Compare the measurement data of phase currents of control devices with the measurement data made by the device, which can be displayed or shown on the PC using the Smart Monitor software in the **Analog values** menu item.

12.6.2 Check of correct connection of voltage transformer circuits

It is necessary to measure secondary voltages of the voltage transformer and make sure they are within the rated value.

Use a phase meter to ensure that the phase sequence matches the phase sequence in the system.

Compare the data of measured phase voltages by control devices with the data of measurements performed by the device, which can be displayed or shown on the PC using the Smart Monitor software in the **Analog values** menu item.

12.6.3 Directional check by load current

This check serves to confirm the correct orientation of directional protection stages (current, distance, power protection). The first step is to determine the actual direction of power. To do this, you can use adjacent measuring devices or protection devices that have already been commissioned.

If there is any doubt about the results obtained, it is necessary to measure phase angles of the current relative to phase angles of the voltage of the same phase.

12.7 Final checks

12.7.1 Disconnect and remove all temporary jumpers and short circuits.



WARNING

It is necessary to remove all test conductors and temporary jumpers, as well as restore all external connections removed during the commissioning checks.

12.7.2 If any external circuits were disconnected for testing, they must be restored in accordance with the connection diagram and other project documentation.



WARNING

In case the conductors of external connections were disconnected, then check with the corresponding diagrams of external connections and circuit diagrams when restoring the connection!

12.7.3 The settings specified in the device must be carefully matched with the settings that need to be specified for a given application of the device. This is to ensure that they have not been mistakenly changed during commissioning checks.

12.7.4 It is necessary to check that all the required protection functions have been enabled.

12.7.5 Before commissioning the device make sure that all records of events, alarms and disturbance records are deleted, as well as that all signals actuated on the indication and output relays are removed and that the warning and alarm LEDs are off.

13 Troubleshooting

13.1 Safety measures

When working with ED2 devices, it is necessary to be guided by local regulations on electrical safety and rules for the safe performance of work.

Specially trained individuals who have studied the documentation for the device and have the necessary qualification to perform these works are allowed to work with the devices.



WARNING

Compliance with this requirement is necessary to prevent electric shock of the operating personnel and the occurrence of other dangerous situations.

When working with the device, take the necessary measures to protect the service personnel from static electricity (ground the device, use an antistatic wrist strap, antistatic stand).



CAUTION

This requirement to static electricity protection is mandatory!

Replacement of components should be carried out when the device is de-energized and measures taken to prevent electric shock to the maintenance personnel.



WARNING

Compliance with this requirement is necessary to prevent electric shock to the maintenance personnel.

The voltage is removed from the device by disconnecting the external power supply.

13.2 General

Failures that occur when energizing and during operation of the device are detected by the continuously functioning self-diagnostic system of the device.

The self-diagnostic system localizes failures and determines their type, dividing them into emergency or warning.

Emergency and warning failures of the device are recorded in the event recorder as well as internal diagnostic files.

Emergency failure (hardware or software) requires immediate interference for its removal, as it disables the device.

The signs of an emergency failure are the following:

- glowing of the "ERROR" LED on the front panel of the device;
- lack of glow of the "READY" LED with the "ON" LED glowing on the front panel of the device.

Note – The "ERROR" LED on the front panel of the device is also on if the device is switched to the "Emulation" mode.

Warning failure indicates faulty service functions (communication, display, hardware synchronization ports). At the same time the device remains in operation, i.e. it performs protective functions. Further operation of the device is possible with elimination of failure at any convenient time.

The signs of a warning failure are the following:

- glowing of the "WARNING" LED on the front panel of the device;
- lack of glow of the "ERROR" LED on the front panel of the device.

Note – The "WARNING" LED on the front panel of the device is also on if a configuration or a new software version has been loaded into the device and a restart of the device is required to apply these parameters.

In most cases, it is sufficient to use the device's HMI to detect and localize a failure. For a more detailed study of the failure that has occurred, you will need the Smart Monitor software (it is recommended to use the latest version). The Smart Monitor software recorded on electronic media is supplied with the device. The latest version of the software package EKRASMS-SP can be downloaded from the website: <https://soft.ekra.ru/smssp/en/downloads/software/>.

13.3 Troubleshooting procedure



NOTICE

If any failures are detected, even in case of self-elimination, it is mandatory to notify the manufacturer!

13.3.1 Switch the device to the "OFF" mode.

To exclude the undesirable effect of the device in the external control and alarm circuits, it is necessary to switch the device to the "OFF" mode or, in the absence of the possibility to disable the device, it is necessary to take measures to exclude the possibility of the device to influence external circuits.

The process of disabling the device is described in item 12.4.

13.3.2 Determine the cause of failure.

Possible causes of device failure are shown in 13.4.

13.3.3 Eliminate the failure.

Possible failure and methods of their self-elimination are shown in 13.4. If the indicated methods did not lead to the elimination of the failure, you should contact the technical support of the manufacturer, having previously generated an archive file for sending to the manufacturer. To generate an archive file, it is necessary to organize communication with the device using the Smart Monitor software, call the main menu item **Device** → **Generate files for sending** (see figure 117).

If there is no communication with the device, you can create an archive for sending to an external drive (USB-flash drive) using the USB port located on the front panel of the device or configure communication in the "Software recovery" mode (see 8.2.3).

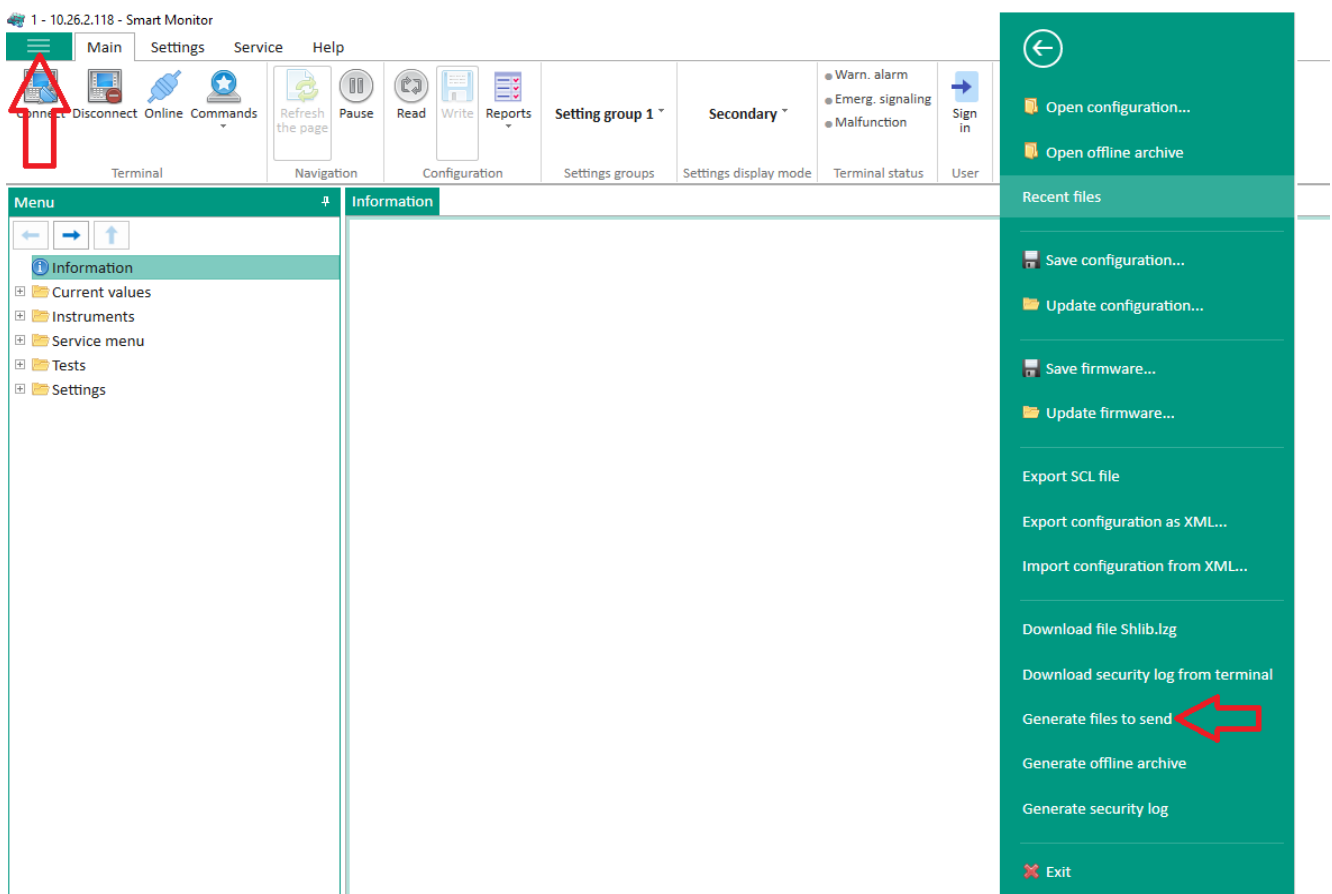

Figure 117 – Generation of files for sending via Smart Monitor software

13.3.4 Reset LED alarm

To reset the LED alarm, use the "Clear alarm" button connected to the "Reset" binary input of the device, a combination (joint pressing) of the "Fn + 0" buttons on the device keyboard or the "Reset alarm" button in the Smart Monitor software.

13.4 Determining cause of device failure and methods for its elimination

13.4.1 To determine the causes of the device failure, detected by the self-diagnostic system of the device, go to the main device menu **Diagnostic** → **State of modules** and press the "↵" ("ENTER") button – to show device errors, or in the Smart Monitor software go to the **Service menu** → **Diagnostic of modules** menu item. In this menu item of the device and the Smart Monitor software, events of three types can be displayed, the description of which is given in table 77.

Table 77 – Types of system events of function (FP) and communication (CP) processors

Event type	Device behavior
Emergency	<ul style="list-style-type: none"> - glowing of the "ERROR" LED on the front panel of the device; - lack of glow of the "READY" LED with the "ON" LED glowing on the front panel of the device; - disabling of output relays; - closed state of NC contacts of the "Ready" output relay located on the power supply module of the device; - in the diagnostic of modules, display of events with the "E" symbol
Warning	<ul style="list-style-type: none"> - glowing of the "WARNING" LED on the front panel of the device; - lack of glow of the "ERROR" LED on the front panel of the device; - output relays of the device remain in operation; - open state of NC contacts of the "Ready" output relay located on the power supply module of the device; - in the diagnostic of modules, display of events with the "W" symbol
Information	<ul style="list-style-type: none"> - lack of glow of the "WARNING" LED on the front panel of the device; - lack of glow of the "ERROR" LED on the front panel of the device; - output relays of the device remain in operation; - open state of NC contacts of the "Ready" output relay located on the power supply module of the device; - in the diagnostic of modules, display of events with the "I" symbol

The possible failure detected by the self-diagnostic system of the device and methods for their elimination are given in tables 78, 79.

Table 78 – Possible emergency failure of the device and methods for their elimination

Displayed message ¹⁾		Cause of failure	Method of elimination ²⁾
1	E Error when recording settings of FP	Critical error detected during configuration initialization	Return to previous operational or factory configuration (see 13.7)
2	E Failure of system ³⁾ modules	Failure of module	<p>One of the modules is faulty (to identify a faulty module, go to the State of modules menu).</p> <p>Note – In the event of a module failure, a logic module failure is additionally displayed.</p> <p>Replace the faulty module from SPTA (see 13.6)</p>
<p>¹⁾ In the message on the display of the device the "E" symbol indicates an emergency failure.</p> <p>²⁾ If the indicated methods did not eliminate the failure, contact the technical support of the manufacturer.</p> <p>³⁾ System modules include: logic module, power supply module, module(s) of analog inputs of alternating current and voltage, module(s) of analog inputs of direct current and voltage, module(s) of binary inputs, module(s) of binary outputs, combined module(s) of binary inputs/outputs, combined power supply and logic module.</p>			

Table 79 – Possible failures of the device and methods for their elimination

Displayed message ¹⁾		Cause of failure	Method of elimination ²⁾
1	W Failure of communication processor	Failure of software of communication processor ³⁾	Reset device
2	W ⁴⁾ Communication processor not responding	Failure of service functions	Reset device
3	W ⁴⁾ Failure of PPS synchronization	Pulse of hardware synchronization of time does not meet the requirements	Apply a pulse that meets the requirements specified in the configuration and documentation or disable PPS time synchronization
4	W Configuration error. Error loading logic	Error updating configuration. The device continues to operate with the current configuration. Error initializing configuration	Return to previous operational or factory configuration (see 13.7)
5	W ⁴⁾ Error applying user parameters	Error detected when writing settings. New settings did not apply. The device continues to operate with old settings	Return to previous operational or factory configuration (see 13.7)
6	W Error testing configuration archive	Error testing configuration: damaged configuration	Return to previous operational or factory configuration (see 13.7)
7	W ⁴⁾ Program error of 61850-GOOSE	Error of device software ³⁾	Reset device
8	W ⁴⁾ Program error of event recorder		
9	W ⁴⁾ Program error of disturbance recorder		
10	W ⁴⁾ Program error of Modbus client		
11	W ⁴⁾ Program error of 61850-MMS		
12	W Program error of service functions		
13	W ⁴⁾ Error working with Flash in disturbance recorder	Configuration files are damaged or there is not enough space on the memory card	If the errors “Error testing core” or “Configuration error” are not set, reduce: the number of signals for disturbance recording and/or time of disturbance recording and/or the number of disturbance records (via device menu or Smart Monitor software)
14	W ⁴⁾ Error working with Flash in event recorder		
15	W Error working with Flash in service functions		
16	W No interruptions from DSP	Communication processor cannot receive data from function processor	Reset device
17	W Error indicating outputs of measuring elements	Error while updating the function of displaying the state of measuring element outputs on service LEDs	Reset device
Table continued on next page			

Displayed message ¹⁾		Cause of failure	Method of elimination ²⁾
18	W Error testing program archive	An error was detected during software initialization ³⁾ . Error of memory card	Reset device
			Replace the memory card (see 13.6)
19	W Error configuring system modules	Error writing new parameters (settings) to the module. New settings did not apply. The device continues to operate with old settings	Reset device
20	W Error configuring service modules		Replace the faulty module from SPTA (to identify the faulty module go to the menu State of modules) (see 13.6)
21	W Error configuring Ethernet redundancy module	Error writing new parameters (settings) to the module. New settings did not apply. The device continues to operate with old settings	Reset device Contact the technical support of the manufacturer
22	W Error working with DSP	The function of reading data from the function processor is disabled due to software errors	Reset device
23	W Error programming system modules	Error reprogramming the module. The program in the module did not change	Reset device
24	W Error programming service modules		Replace the module from SPTA (to identify the faulty module go to the menu State of modules) (see 13.6)
25	W Low CMOS battery	Error of BIOS power supply element. It is set if the date and time saved during the previous operation of the device exceeds the current system time. It is reset when checking the system time when loading the device. The battery in the logic module is discharged	Replace the battery (<i>form-factor CR2032</i>) in the logic module (see 13.6)
26	W Error of GOOSE protocol parameters	Error when initializing communication protocols	Return to previous operational or factory configuration (see 13.7)
27	W Error of Modbus client protocol parameters		
28	W Error of server protocol parameters		
29	W Error executing FLOC function	Error during fault localization	Reset device
30	W Emergency Error occurred	Emergency Error appeared	Press the "Clear alarm" button connected to the "Reset" binary input of the device or a combination of "Fn + 0" buttons on the device keyboard or by pressing the "Reset alarm" button in the Smart Monitor software

Table continued on next page

Displayed message ¹⁾		Cause of failure	Method of elimination ²⁾
31	W ⁴⁾ Error calculating expressions	Error calculating calculated values	Press the "Clear alarm" button connected to the "Reset" binary input of the device or a combination of "Fn + 0" buttons on the device keyboard or by pressing the "Reset alarm" button in the Smart Monitor software
32	W Error loading access rights	Administration parameters reset	Set user administration parameters via Smart Monitor software (User administration menu)
33	W ⁴⁾ Blocking operation of disturbance recorder	Disturbance recording is blocked	Reset device
34	W ⁴⁾ Blocking calculation of calculated values	Calculation of calculated values is blocked	Press the "Clear alarm" button connected to the "Reset" binary input of the device or a combination of "Fn + 0" buttons on the device keyboard or by pressing the "Reset alarm" button in the Smart Monitor software
35	W Error initializing Ethernet	Error initializing network interfaces	Correct network parameters and network protocols via Smart Monitor software (menu Settings → Digital communication channels)
36	W Reset required to apply parameters	System parameters modified	Reset device
37	W Module software version 9.2 SV not supported	Error receiving signals via IEC 61850-9-2LE protocol	Contact the technical support of the manufacturer
38	W ⁴⁾ Out of Host memory	Not enough memory for software operation	Reset device
			Contact the technical support of the manufacturer
39	W ADC calibration required	Modules of analog inputs not calibrated	Calibrate the modules of analog inputs using Smart Monitor software (Service menu → ADC calibration)
40	W ⁴⁾ Error of IRIG-B synchronization	IRIG-B time synchronization signal does not meet the requirements	Check installation. Check the state of synchronizing device. Check device settings
			Contact the technical support of the manufacturer
41	W Malfunction of IRIG-B synchronization module	Error working with synchronization module	Check installation. Check the state of synchronizing device. Check device settings. Reset device
			Contact the technical support of the manufacturer
Table continued on next page			

Displayed message ¹⁾		Cause of failure	Method of elimination ²⁾
42	W ⁴⁾ Error loading state of logic and ES	Device power was off for a long time	Reset device
			Press the "Clear alarm" button connected to the "Reset" binary input of the device or a combination of "Fn + 0" buttons on the device keyboard or by pressing the "Reset alarm" button in the Smart Monitor software
43	E Error when recording configuration of FP	Error working with the configuration in FP	Reset device
44	E Error applying configuration of FP		
45	E Not enough computing resources of FP	When executing the FP program, the execution time of configuration algorithms exceeded the program cycle time	Contact the technical support of the manufacturer
46	E Error of data memory checksum	A violation of data integrity was detected during internal self-diagnostic of FP memory	Reset device
47	E Error of program memory checksum		Contact the technical support of the manufacturer
48	E Error of checksum of external memory	A violation of integrity of external memory was detected during internal self-diagnostic of FP memory	Reset device
			Press the "Clear alarm" button connected to the "Reset" binary input of the device or a combination of "Fn + 0" buttons on the device keyboard or by pressing the "Reset alarm" button in the Smart Monitor software
49	W ⁴⁾ Error of checksum of non-volatile memory of macrolanguage	A violation of data integrity of non-volatile memory was detected during internal self-diagnostic of external memory of macrolanguage FP	Reset device
			Press the "Clear alarm" button connected to the "Reset" binary input of the device or a combination of "Fn + 0" buttons on the device keyboard or by pressing the "Reset alarm" button in the Smart Monitor software
50	W ⁴⁾ Error assigning synchronization source	Failed to assign the required time synchronization source	Replace the logic module from SPTA (see 13.6)
51	W <Call> signal present for more than 10 sec	Possible failure of the "CALL" of signal	Remove voltage from the "CALL" binary input. Check installation
52	W <Reset> signal present for more than 10 sec	Possible failure of the "RESET" signal	Remove voltage from the "RESET" binary input. Check installation
53	W Unstable communication with peripheral modules	Communication errors between modules periodically occur	Replace the faulty module with a module from SPTA
			Contact the technical support of the manufacturer

Table continued on next page

Displayed message ¹⁾		Cause of failure	Method of elimination ²⁾
54	W Error reading fixed alarm	Device power was off for a long time	Press the "Clear alarm" button connected to the "Reset" binary input of the device or a combination of "Fn + 0" buttons on the device keyboard or by pressing the "Reset alarm" button in the Smart Monitor software
<p>¹⁾ In the message on the display of the device the "W" symbol indicates a warning failure, the "E" symbol – an emergency failure, the "I" symbol – an information event.</p> <p>²⁾ If the indicated methods did not eliminate the failure, contact the technical support of the manufacturer.</p> <p>³⁾ This type of failure leads to the disconnection of some functions, including:</p> <ul style="list-style-type: none"> - operation of communication protocols; - event recorder; - disturbance recorder; - FLOC function (fault location); - calculation of calculated values. <p>⁴⁾ This type of event is set as warning W by default. Using the Configurator application software, the type can be changed to emergency E or informational I.</p>			

13.4.2 Description of failure not covered by the self-diagnostic system of the device, their causes and methods of elimination are given in table 80.

Table 80 – Possible failures of the device and methods for their elimination

Description of malfunction		Possible cause of malfunction	Method of elimination ¹⁾
1	Device does not turn on (the display does not show information and LED indication is not on)	Incorrect connection of an external power supply to device terminals	Check the connection scheme
		Device's power supply circuit installation is damaged	Check the integrity of power supply circuit installation
		Low power supply voltage	Apply the required level of power supply
		Faulty power supply module of the device	Replace the power supply module from SPTA (see 13.6)
		If the display does not show information, and LED indication is on, then the logic module of the device is faulty	Replace the logic module from SPTA (see 13.6)
2	Device automatically switched to "Software recovery" mode	Errors in the configuration of the device	Return to previous operational or factory configuration (see 13.7)
		Error of device software	Return to previous operational or factory software (see 13.7)
3	Device not loading	Incompatible configuration and software	If the device is not loading after replacement of the configuration, write the software corresponding to the configuration. If the device is not loading after replacement of the software, write the configuration corresponding to the software version
		Failure of device display	Replace the indication module from SPTA (see 13.6)
		Failure of logic module	Replace the logic module from SPTA (see 13.6)
Table continued on next page			

Description of malfunction		Possible cause of malfunction	Method of elimination ¹⁾
4	Lack of communication with the device via RS-485 interface. The device remains serviceable	Incorrect communication parameters in the device	Make sure the used address of the device is free in the current network. Set the correct address Set a lower rate of port operation. When choosing the rate follow the rule: the longer the length of the communication line, the lower the rate
		Installation errors.	Check the polarity of interface signals. Set the polarity according to designation
		Damaged communication cable	Check the communication cable, replace with a non-faulty one that meets the requirements
		When communicating via Smart Monitor software – inconsistency of communication parameters between the device and the Smart Monitor software	Make sure the port operation rate and address of the device in the settings of the device and the Smart Monitor software are compatible
5	Lack of communication with the device via Ethernet interface. The device remains serviceable	Incorrect communication parameters in the device	Make sure the used address of the device is free in the current network. Set the correct address Make sure the used IP address of the device is free in the current network. Set the correct address
		Damaged communication cable	Check communication cable, replace with a non-faulty one that meets the requirements
		When communicating via Smart Monitor software – inconsistency of communication parameters between the device and the Smart Monitor software	Make sure the subnet mask specified in the device is compatible with the PC where the Smart Monitor software is installed If the device and the PC where the Smart Monitor software is installed are in different subnets, make sure the gateway numbers specified in the device and the PC are compatible
		Does not support device configuration when communicating via Smart Monitor software	Update Smart Monitor
6	Unstable communication with the device	Interference in the communication line	Eliminate interference. Make sure shielded communication cables are used
		Failure of external equipment for arrangement of communication (switches, etc.)	Check correct operation of external equipment, check the accuracy of setting
		Failure of RS-485 interface	The RS-485 interface troubleshooting procedure is described above
8	Lack of communication via Modbus TCP protocol	Failure of Ethernet interface	The Ethernet interface troubleshooting procedure is described above
		Protocol is disabled	Enable the protocol via Smart Monitor software or the menu of the device
Table continued on next page			

Description of malfunction		Possible cause of malfunction	Method of elimination ¹⁾
9	Lack of communication via IEC 60870-5-103 protocol	Failure of RS-485 interface	The RS-485 interface troubleshooting procedure is described above
		Protocol is missing in the configuration	Not a failure. Add the protocol using the Configurator or Smart Monitor software
		Protocol is disabled	Enable the protocol via Smart Monitor software or the menu of the device
10	Lack of communication via IEC 60870-5-104 protocol	Failure of Ethernet interface	The Ethernet interface troubleshooting procedure is described above
		Protocol is missing in the configuration	Not a failure. Add the protocol using the Configurator or Smart Monitor software
		Protocol is disabled	Enable the protocol via Smart Monitor software or the menu of the device
11	Device does not send GOOSE messages	Failure of Ethernet interface	The Ethernet interface troubleshooting procedure is described above
		Protocol is missing in the configuration	Not a failure. Communication protocols are determined by the Customer when ordering the device
		Outgoing GOOSE are not enabled in the configuration	Enable outgoing GOOSE via Smart Monitor software
		Incorrect setting parameters	Check and set correct parameters of setting via Smart Monitor software
		Emergency Error of the device	Eliminate emergency failure of the device
		Failure of external equipment for arrangement of communication (switches, etc.)	Check correct operation of external equipment for arrangement of communication, check the accuracy of setting
12	Device does not receive GOOSE messages	Failure of Ethernet interface	The Ethernet interface troubleshooting procedure is described above
		Protocol is missing in the configuration	Not a failure. Communication protocols are determined by the Customer when ordering the device
		Incoming GOOSE are not enabled in the configuration	Enable incoming GOOSE via Smart Monitor software
		Incorrect setting parameters	Check and set correct parameters via Smart Monitor software
		Incompatible parameters of GOOSE message	Make sure the parameters of the incoming GOOSE message in the configuration of the device are the same as those of the sender: MAC address, application identifier (AppID), GOOSE identifier (GoID), configuration version (CnfRev). Check the correspondence of data types in the message. In the incoming GOOSE message the value of the Test field must be "False"
		Failure of external equipment for arrangement of communication (switches, etc.)	Check correct operation of external equipment for arrangement of communication, check the accuracy of setting
Table continued on next page			

Description of malfunction		Possible cause of malfunction	Method of elimination ¹⁾
13	Failed to connect to the device via MMS	Failure of Ethernet interface	The Ethernet interface troubleshooting procedure is described above
		Protocol is missing in the configuration	Not a failure. Communication protocols are determined by the Customer when ordering the device
		61850 protocol disabled in configuration	Enable 61850 protocol via Smart Monitor software
		Incorrect parameters of data sets, report modules (loading error)	Check and set correct parameters via Smart Monitor software
		Errors when loading the device, protocols were loaded by default	Eliminate loading errors of the device
		Maximum quantity of concurrent clients exceeded	Using Smart Monitor software set the quantity of report modules according to the quantity of clients for all data sets
		Error of external equipment for arrangement of communication (switches, etc.)	Check correct operation of external equipment for arrangement of communication, check the accuracy of setting
14	The client does not subscribe to the report module	The report module is already used by another client, the quantity of report modules does not correspond to the quantity of clients	Add the required quantity of report modules. Set up the client for subscription to report modules
15	Time synchronization errors	Incorrect parameters of time synchronization setting	The procedure for setting and troubleshooting is given in the section of the operation manual "Communication, time synchronization and network redundancy protocols manual"
¹⁾ If the indicated methods did not eliminate the malfunction, contact the technical support of the manufacturer.			

13.5 General principle of device disassembly and module removal

13.5.1 The procedure for disassembling the device and replacing faulty modules is given on the example of the ED2 devices of 1/3 19" design. For other devices, the actions will be similar.

13.5.1.1 Disconnect all terminal blocks and plug connector(s) of the device (including installation) from the plugs, having previously unscrewed the standard connection screws (shown in figure 118 with red dash-dotted lines).

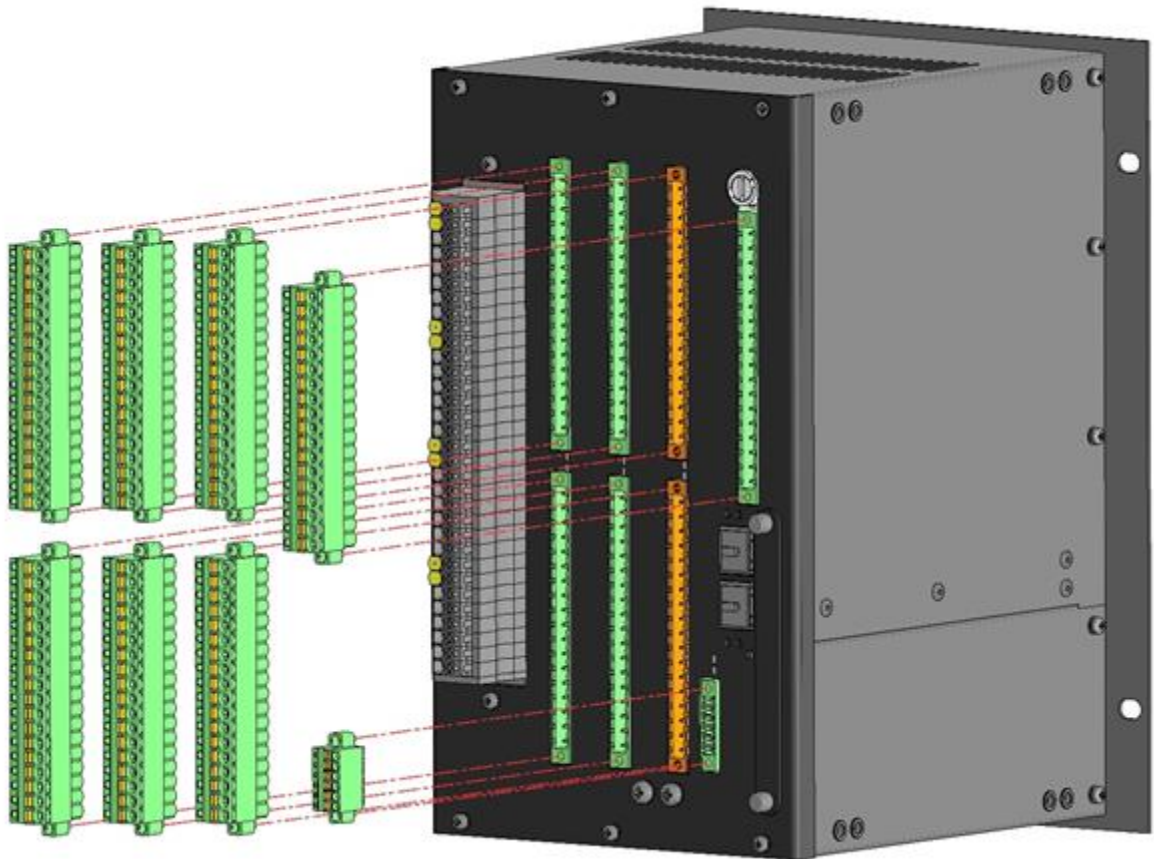

Figure 118 – Location of screws securing terminal blocks

13.5.1.2 If there are redundant power units, you must first remove them according to the procedure given in section 13.6.1.

13.5.1.3 Disconnect the earthing cable from the back plate of the device.

13.5.1.4 Remove the back plate of the device by unscrewing all the fastening screws, and unscrew the two screws securing the module to the frame, in case of the module version without the front plate (figure 119).

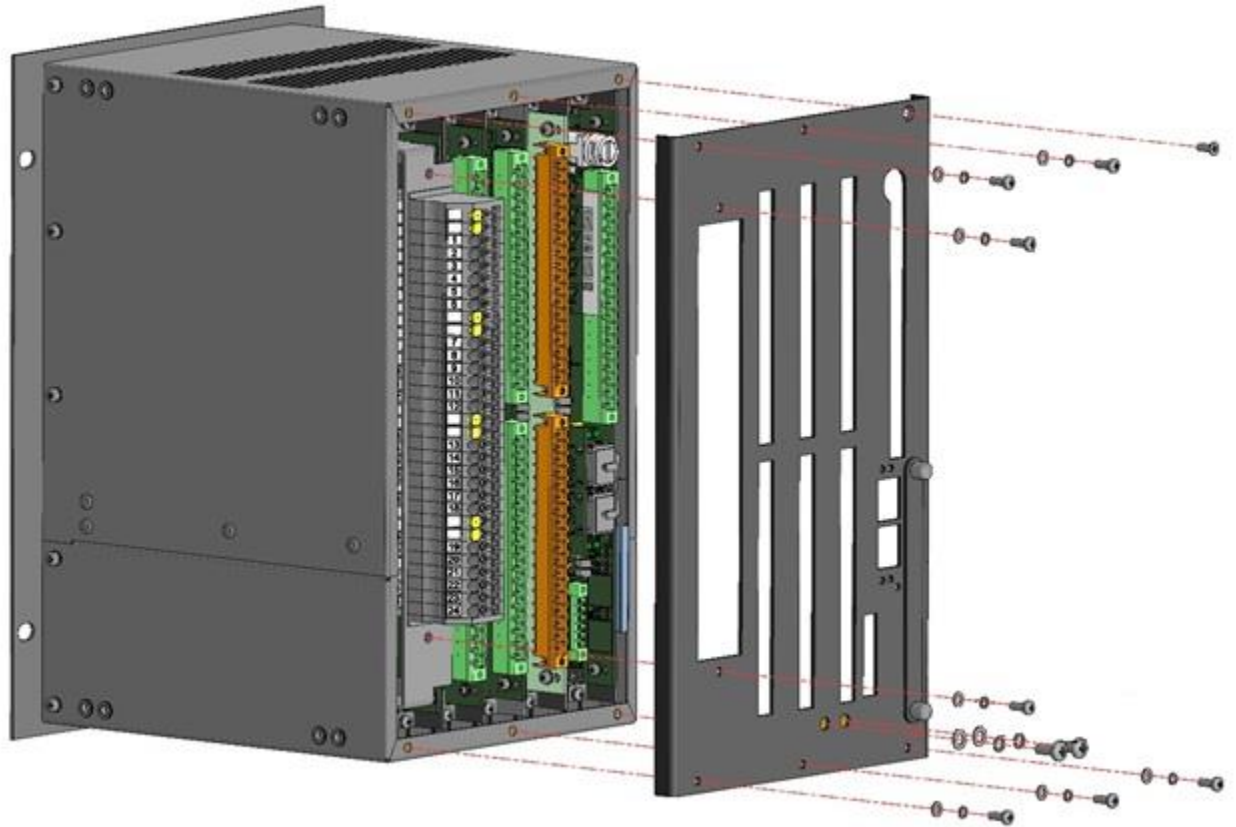

Figure 119 – Location of screws securing back plate

13.5.1.5 Remove the two screws securing the required module. One screw is at the top of the module, the other – at the bottom (figure 120).

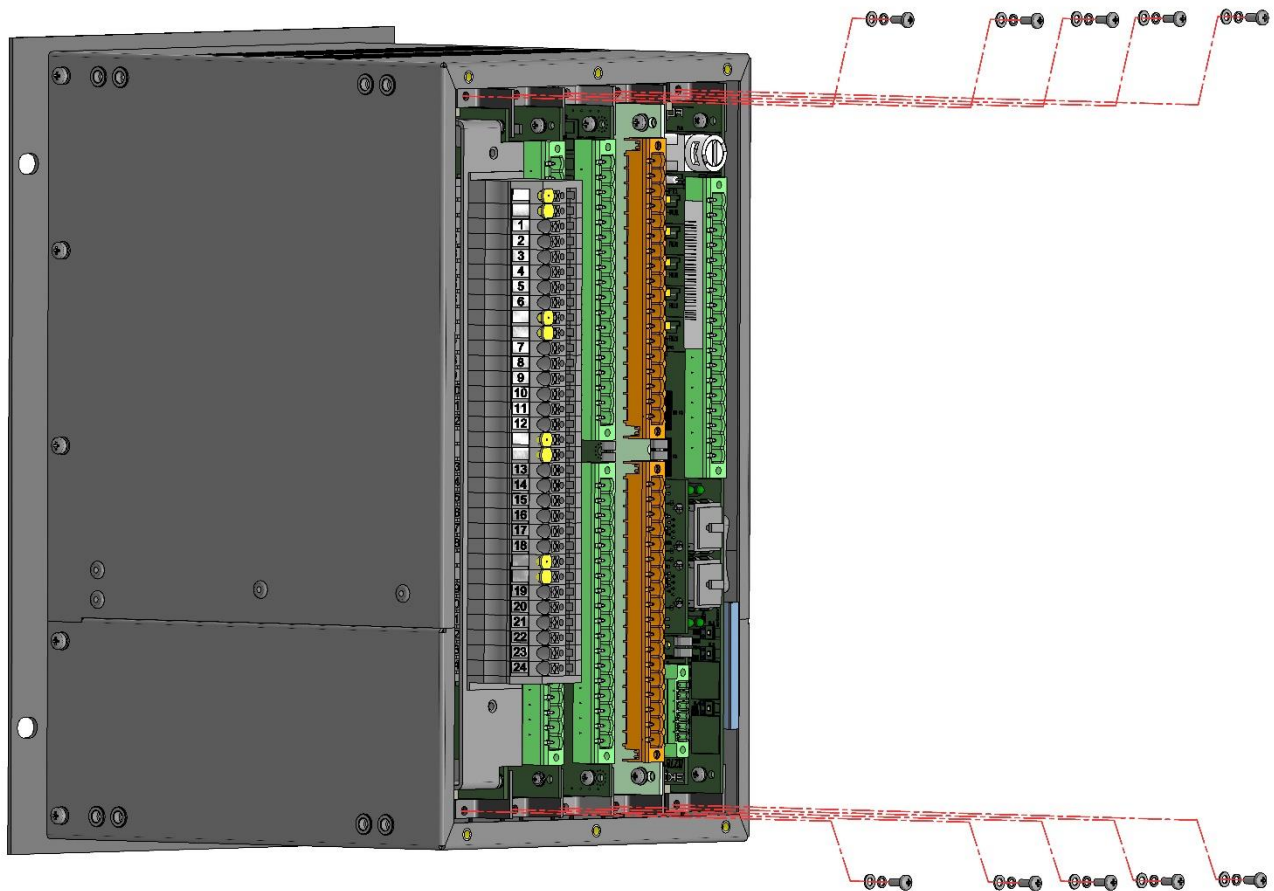

Figure 120 – Location of screws securing modules inside the device

13.5.1.6 Remove the module from the device. To do this, carefully pull the module out of its installation location. When removing it, we recommend holding the module either by the external connector or by the corners of attachment to the frame (figure 121).

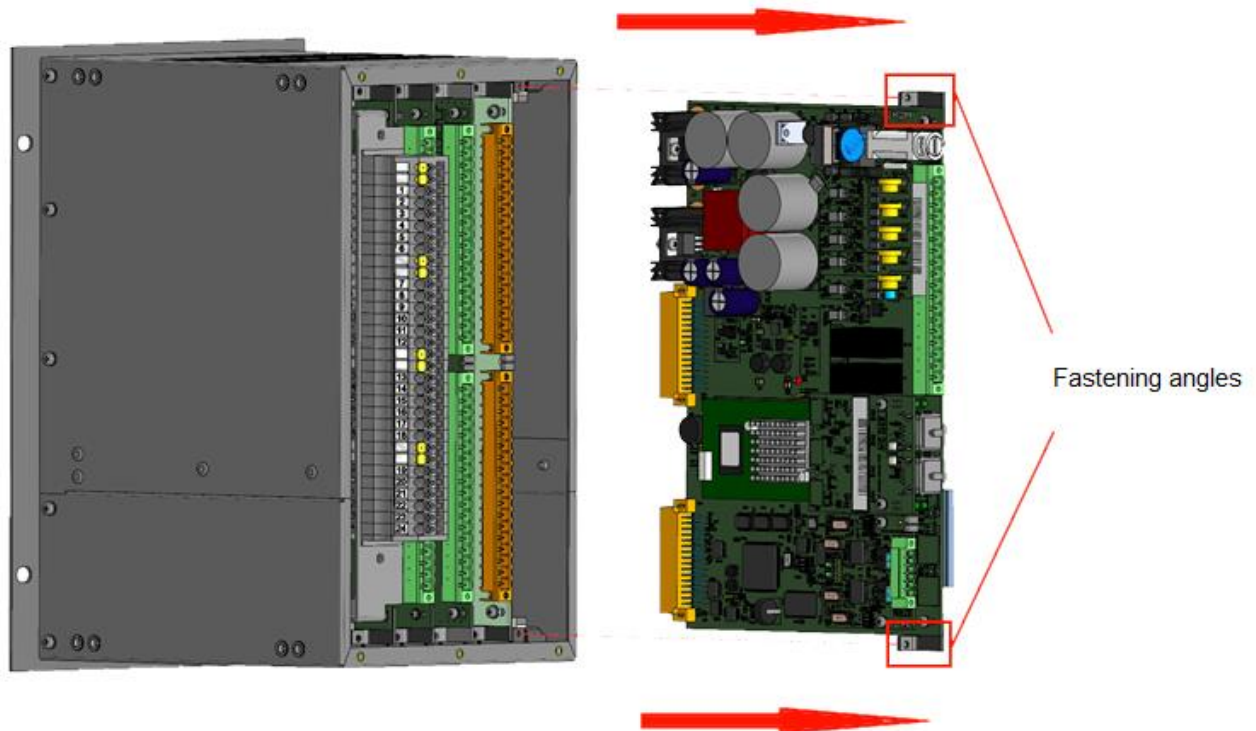

Figure 121 – Removal of the module from the device

13.5.2 Install the module and assemble the device in reverse order.

13.6 Replacement of device components

To replace any module, you must first disassemble the device according to the recommendations of section 13.5.

13.6.1 Replacement of logic module

For $\frac{1}{3}$ 19" devices, the logic module is combined with the power supply module and its replacement must be carried out according to the recommendations given in this section.

The faulty logic module must be replaced with a module of the same design from the SPTA set.

13.6.1.1 Procedure for replacing a faulty logic module

13.6.1.1.1 Remove the module from the device.

13.6.1.1.2 Remove the memory card (Compact Flash) from the slot and insert it into the non-faulty logic module, following the card orientation relative to the slot. Do not use excessive force to insert the memory card into the slot, as in case of the incorrect position, the card and the slot may be damaged.

Note – The logic module from the SPTA set is completed with converter and/or communication modules and/or adapter and/or time synchronization modules, that is why it is not required to reinstall them from the faulty module.

13.6.1.1.3 Install the module in the device in reverse order.

13.6.2 Replacement of BIOS battery

13.6.2.1 BIOS battery has form-factor CR2032 ("tablet" type). The location of the battery in the logic module depends on the module type.



Replace the battery only with a battery of the same type CR 2032 or BR 2032!



Batteries may only be replaced with equivalent batteries of the same type or another type recommended by the manufacturer. Installing the wrong type of batteries can cause an explosion. Follow the relevant national/international regulations for battery disposal.



The lithium batteries installed in the device may only be replaced by qualified personnel.

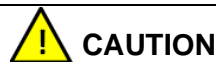

Improper handling of the battery used in the device may result in fire or chemical burns.



Batteries must not be re-charged, disassembled or heated to temperatures exceeding 100°C.



Discharged batteries must be replaced immediately and disposed of.

13.6.2.2 In logic modules the slot with the battery is located on the edge of the outer side of the module and there is no need to remove the module to replace the battery. The back plate of the device may contain a hole for removing the battery (see figure 122). In this case, removing the back plate of the device is not required. It is necessary to unscrew the two screws, remove the cover closing the hole, and remove the battery.

13.6.2.3 To replace the battery, pull the tray with the battery out of the slot (see figure 15 a), b), replace the battery and insert the tray back into the slot until it stops (there should be a specific click). The negative side (-) of the battery should face the board. This type of work must be done with tweezers.

13.6.3 Replacement of memory card (Compact Flash)

13.6.3.1 The memory card is not included in the SPTA set, it must be removed from the logic module of the faulty device.

13.6.3.2 Procedure for replacing of memory card

13.6.3.2.1 In logic modules, the slot with the memory card is located on the edge of the outer side of the module and there is no need to remove the module to replace the card. The back plate of the device may contain a hole for removing the battery (see figure 122, a, b)). In this case, removing the back plate of the device is not required. It is necessary to unscrew the two screws, remove the cover closing the hole, and remove the battery. To remove the card, you must press the eject button located below the slot.

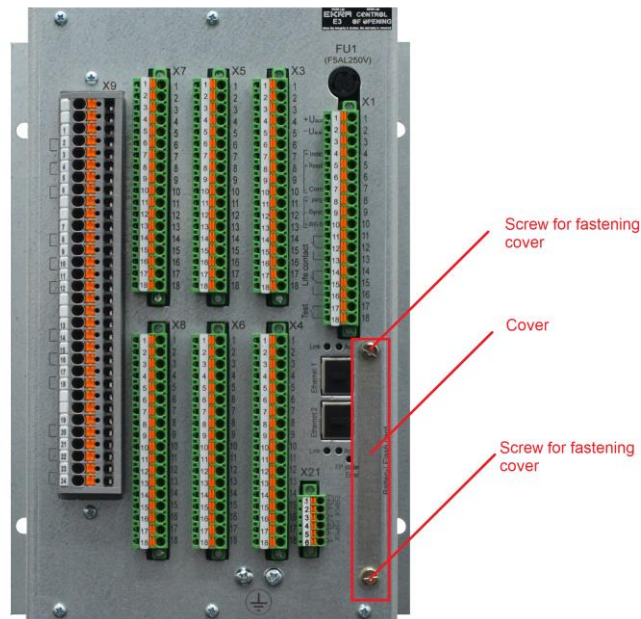

a) common cover for battery and memory card

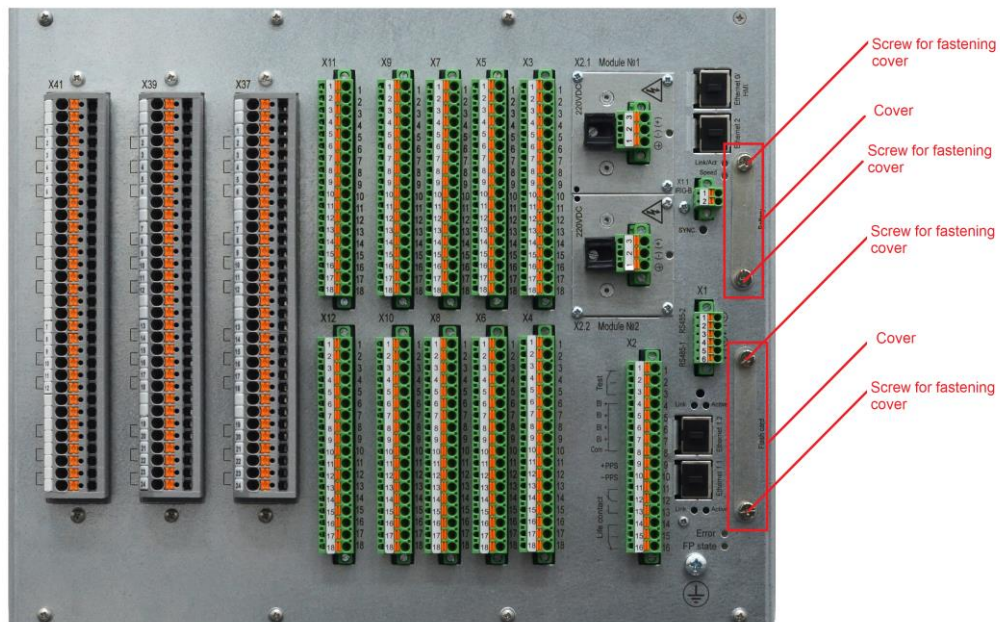

b) separate covers for battery and memory card

Figure 122 – Cover for memory card and battery of the device with logic modules

13.6.4 Replacement of the converter unit, communication unit, time synchronization unit.

13.6.4.1 The faulty converter module, adapter module, communication module and time synchronization module must be replaced with a module of the same version from the SPTA set.

13.6.4.2 Procedure for replacing a faulty module

13.6.4.2.1 Remove the logic module from the device

13.6.4.2.2 Unscrew the two screws securing the module to the logic module.

13.6.4.2.3 Remove the module from the connector by gently pulling it perpendicular to the plane of the logic module board.

13.6.4.2.4 Install the non-faulty module in place of the dismantled one, following the orientation of the module relative to the logic module.

13.6.4.2.5 Install the logic module in the device in reverse order.

13.6.5 Replacing of module of binary inputs, binary outputs, module of binary inputs/outputs



WARNING

Dangerous voltage from external control and automation devices may be present at the connectors of binary inputs and outputs!

13.6.5.1 The faulty module of binary inputs, binary outputs and binary inputs/outputs must be replaced with a module of the same version from the SPTA set.

13.6.5.2 Procedure for replacing a faulty module

13.6.5.2.1 Remove the module from the device.

13.6.5.2.2 Install the module in the device in reverse order.

13.6.6 Replacing of a power supply module

For 1/3 19" devices, the power supply unit is combined with the logic module and its replacement must be carried out according to the recommendations for replacing the logic module in clause 13.6.1.

13.6.6.1 The faulty power supply module must be replaced with a module of the same version from the SPTA set.

13.6.6.2 Procedure for replacing a faulty module

13.6.6.2.1 Remove the module from the device.

13.6.6.2.2 Install the module in the device in reverse order.

13.6.6.2.3 Replacement of the power supply fuse

Replacing the power supply fuse is available only for the combined logic and power module without support for power redundancy and occurs without disassembling the device itself (figure 123). Other power modules have a non-removable fuse on the board.

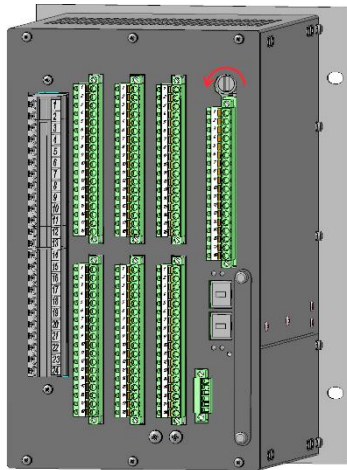

a) Turning the power supply fuse

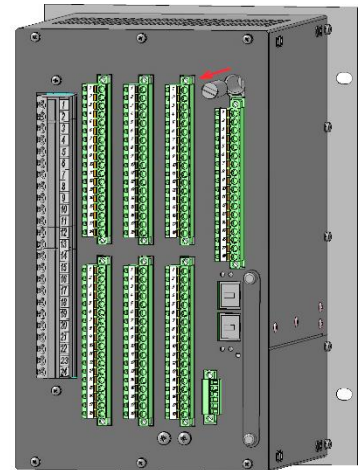

b) Removing the power supply fuse

Figure 123 – Replacement of the power supply fuse

13.6.1 Procedure for replacing a defective redundant power supply unit



WARNING

It is permissible to replace redundant power unit without turning off the device and taking it out of operation. But for safety reasons, you must first de-energize the circuits connected to the socket of the unit being replaced

13.6.1.1 A redundant power supply module can be equipped with two independent redundant power supply unit as shown in the figure 124.

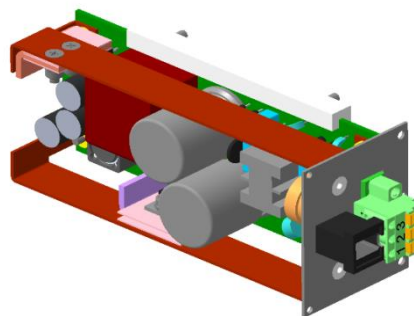

Figure 124 – Redundant independent power supply unit

13.6.1.2 Disconnect the socket on the faulty module (with installation) from the plug, having previously unscrewed standard connection screws.

13.6.1.3 Unscrew the three screws securing the module from the back plate of the device (see figure 125, a)).

13.6.1.4 Remove the module from the device.

13.6.1.5 Install the non-faulty module in the device in reverse order; in this case, pay attention, the installation of the module should be carried out along the slide rails (see figure 125, b)).

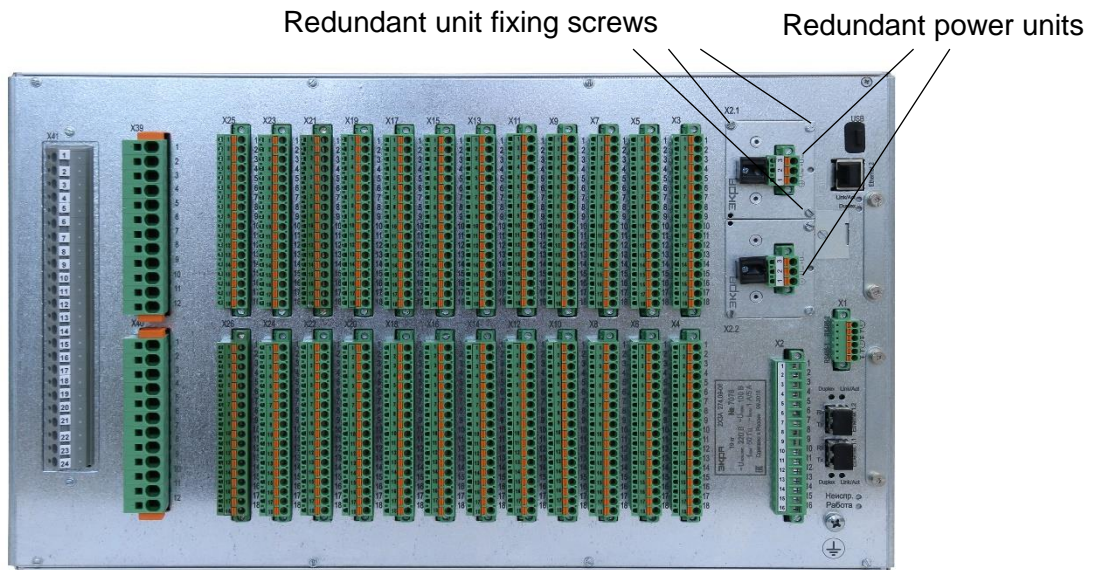

a) location of redundant power supply units on the rear plate of device, rear view

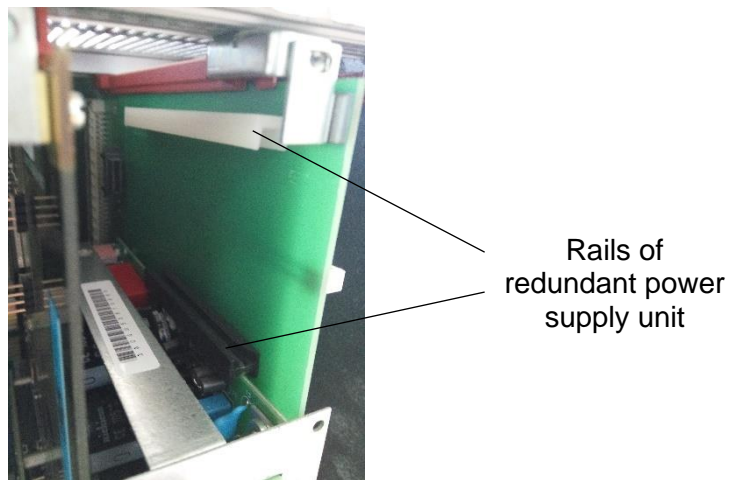

b) rear plate of the device with removed redundant power unit, rear view

Figure 125 – Replacing a failed plug-in power unit

13.6.2 Replacing a faulty indication module

13.6.2.1 The faulty indication module must be replaced with a module of the same version from the SPTA set.

13.6.2.2 Procedure for replacing a faulty module

ED2 devices of 1/3 19" design have a non-removable indication module, which is a part of the device enclosure. Therefore, it cannot be replaced separately. If it becomes necessary to replace the indication module on this device, please contact the manufacturer.

13.6.2.3 Unscrew all the screws securing the module to the cassette (see figure 126), holding the module with a hand in order to prevent the module from falling.

13.6.2.4 Gently disconnect the flexible connection of the module with the motherboard (see figure 126).

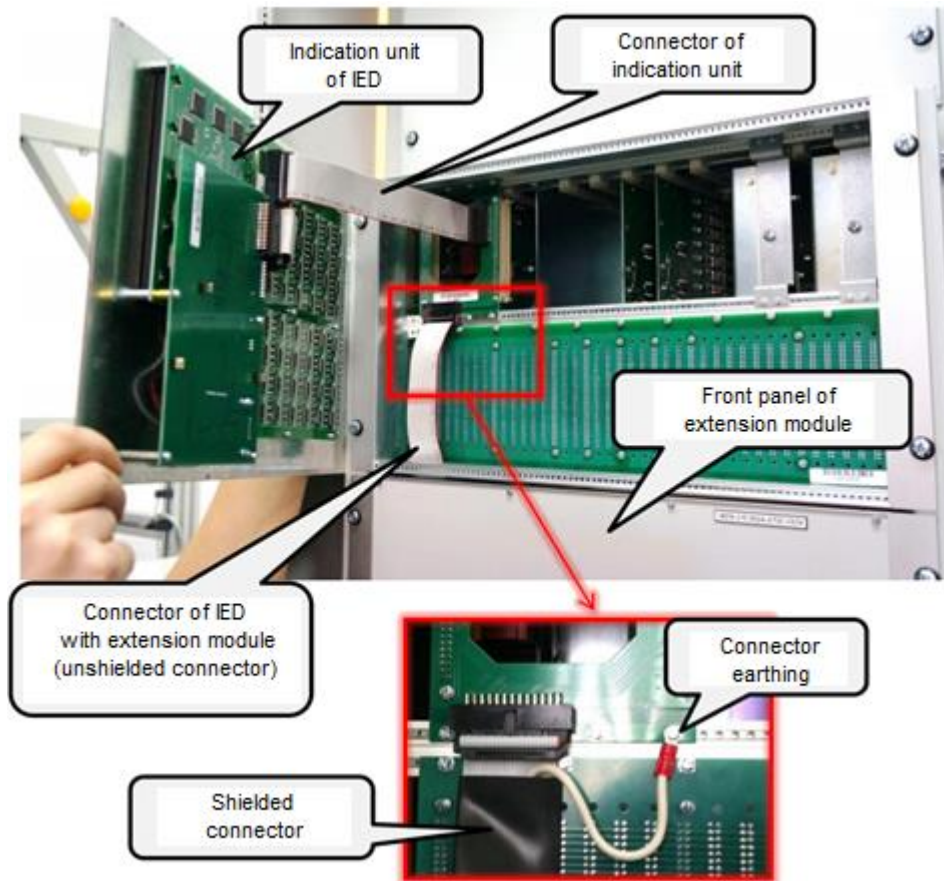

Figure 126 – Removal of the indication module from the device

13.6.2.5 Remove information plates (using tweezers) from the module and install them in the non-faulty module, strictly following their arrangement.

13.6.2.6 Install the module in the device in reverse order.

13.6.3 Replacing a faulty transformerless analog input module

13.6.3.1 The faulty module of analog input must be replaced with a module of the same version from the SPTA set.

13.6.3.2 Procedure for replacing a faulty module

 **WARNING**

Precautions must be taken to prevent damage to the equipment and the exposure of replacement personnel to voltage. Provide shorting of external current circuits and breaking of voltage circuits.



WARNING

In the absence of test modules for current circuits, ensure a short-circuit at the terminals (in case of using specialized terminals, remove the short-circuiting plugs from them), for voltage circuits, provide a break at the terminals using disconnectors.

13.6.3.2.1 Disconnect all sockets (with installation) from plugs.

13.6.3.2.2 Disconnect the earthing cable from the back plate of the device.

13.6.3.2.3 Remove the right back plate of the device by unscrewing all the fastening screws and unscrew the two screws securing the module to the cassette.

13.6.3.2.4 Remove the module from the device.

13.6.3.2.5 Install the module in the device in reverse order.

13.6.4 Replacing a faulty transformer analog input

13.6.4.1 The faulty transformer analog input module must be replaced with a module of the same version from the SPTA set.

13.6.4.2 Procedure for replacing a faulty module



WARNING

Precautions must be taken to prevent damage to the equipment and the exposure of replacement personnel to voltage. Provide shorting of external current circuits and breaking of voltage circuits.

13.6.4.2.1 If the device is part of a cabinet, then this can be done in the following ways:

- remove operating covers, if there are test modules;
- in the absence of test modules for current circuits, ensure a short circuit at the terminals (in case of using specialized terminals, remove the short-circuiting plugs from them; for voltage circuits, ensure a break at the terminals using disconnectors.



NOTICE

When removing the module, hold it firmly as the analog input transformer module is heavy due to the current and voltage transformers installed in it.

13.6.4.2.2 Remove the module from the device.

13.6.4.2.3 Install the module in the device in reverse order.

13.7 Replacement and/or recovery of configuration and software

13.7.1 With any changes of parameters of the device (system parameters, settings, setpoints, etc.) and their saving (device menu **Save settings**) a new configuration with new parameters is automatically generated. In this case, the previous version of the configuration is saved in the non-volatile memory (memory card) of the device.

Replacement and/or recovery of the configuration and software of the device can be done in three ways:

- 1) via Smart Monitor software using the "Configuration and software update" function;
- 2) using a USB-flash drive, connecting it to the USB connector of the drive. When connected, an additional **USB drive** menu appears on the screen. In this menu, select item **3 Update** (see 8.2).

In this case, the previous version of the software is saved in the non-volatile memory (memory card) of the device;

- 3) via device menu in the "Software recovery" mode (see 8.3).

13.7.2 Recovery of the device configuration can be done:

- 1) if there is a previous version of the configuration via Smart Monitor software (software complex (EKRASMS-SP) using the **Configuration and software update** function (see the "EKRASMS-SP software package" document).

Note – If there is no communication with the device according to the current configuration parameters, set up communication in the "Software recovery" mode using the default communication parameters (see 8.2.4);

- 2) if there is a previous version of the configuration using a USB-flash drive, connecting it to the USB connector of the drive. When connected, an additional **USB drive** menu appears on the screen. In this menu, select item **3 Updating** (see 8.2);

- 3) via device menu in the "Software recovery" mode (see 8.3).

13.7.3 Recovery of the device software can be done:

- 1) if there is a previous version of the device software via Smart Monitor software (software complex EKRASMS-SP), using the **Configuration and software update** function (see the "EKRASMS-SP software package" document).

Note – If there is no communication with the device according to the current configuration parameters, set up communication in the "Software recovery" mode using the default communication parameters (see 8.2.4);

- 2) if there is a previous version of the software using a USB-flash drive, connecting it to the USB connector of the drive. When connected, an additional **USB drive** menu appears on the screen. In this menu, select item **3 Updating** (see 8.2);

- 3) via device menu in the "Software recovery" mode (see 8.3).